

Studies on Rapid Ion-Exchange Separation
of The Transplutonium Elements
With Mineral Acid-Methanol Mixed Media

March 1989

日本原子力研究所

Japan Atomic Energy Research Institute

日本原子力研究所研究成果編集委員会

委員長 吉川 允二(理事)

委 員

井川 勝市(燃料・材料工学部)	備後 一義(保健物理部)
石黒 幸雄(原子炉工学部)	藤城 俊夫(燃料安全工学部)
岩田 忠夫(物理部)	藤野 威男(化学部)
江連 秀夫(動力試験炉部)	船橋 昭昌(臨界プラズマ研究部)
海老沼幸夫(技術情報部)	幕内 恵三(開発部)
金子 義彦(原子炉工学部)	宮田定次郎(研究部)
工藤 博司(アイソトープ部)	宮本 喜晟(高温工学部)
近藤 育郎(JT-60試験部)	森内 茂(環境安全研究部)
齊藤 伸三(高温工学試験研究炉設計室)	安川 茂(動力炉開発・安全性研究管理部)
白井 英次(研究炉管理部)	八巻 治恵(原子力船技術部)
竹田 辰興(核融合研究部)	山本 章(材料試験炉部)
立川 圓造(化学部)	横村 武宣(原子力船研究開発室)
飛岡 利明(原子炉安全工学部)	吉田 弘幸(企画室)
中井 洋太(物理部)	

Japan Atomic Energy Research Institute

Board of Editors

Masaji Yoshikawa (Chief Editor)

Kazuyoshi Bingo	Yukio Ebinuma	Hideo Ezure
Takeo Fujino	Toshio Fujishiro	Akimasa Funahashi
Katsuichi Ikawa	Yukio Ishiguro	Tadao Iwata
Yoshihiko Kaneko	Ikuro Kondo	Hiroshi Kudo
Keizo Makuuchi	Yoshiaki Miyamoto	Teiji Miyata
Shigeru Moriuchi	Yohta Nakai	Shinzo Saito
Eiji Shirai	Enzo Tachikawa	Tatsuoki Takeda
Toshiaki Tobioka	Jikei Yamaki	Akira Yamamoto
Shigeru Yasukawa	Takeyoshi Yokomura	Hiroyuki Yoshida

JAERIレポートは、日本原子力研究所が研究成果編集委員会の審査を経て不定期に公開している研究報告書です。

入手の問合わせは、日本原子力研究所技術情報部情報資料課(〒319-11茨城県那珂郡東海村)あて、お申しこしてください。なお、このほかに財団法人原子力弘済会資料センター(〒319-11 茨城県那珂郡東海村日本原子力研究所内)で複写による実費頒布をおこなっております。

JAERI reports are reviewed by the Board of Editors and issued irregularly.

Inquiries about availability of the reports should be addressed to Information Division Department of Technical Information, Japan Atomic Energy Research Institute, Tokai-mura, Naka-gun, Ibaraki-ken 319-11, Japan.

©Japan Atomic Energy Research Institute, 1989

編集兼発行 日本原子力研究所
印刷 いばらき印刷株

STUDIES ON RAPID ION-EXCHANGE SEPARATION OF THE TRANSPLUTONIUM ELEMENTS WITH MINERAL ACID-METHANOL MIXED MEDIA

Shigekazu USUDA

Department of Fuel Safety Research
Tokai Research Establishment
Japan Atomic Energy Research Institute
Tokai-mura, Naka-gun, Ibaraki-ken

(Received October 4, 1988)

Summary

In order to study properties of short-lived transplutonium nuclides synthesized by heavy-ion bombardment, three methods for rapid separation of tri-valent transplutonium elements by ion-exchange chromatography with mineral acid-methanol mixed media at elevated temperature were investigated. The mixed media, methanol solutions mixed with a small quantity of mineral acid (nitric or hydrochloric acid), have low viscosity and high evaporation rates. The effluents have salt-free characteristics. Therefore, these methods enabled the rapid separation of the transplutonium elements and the immediate preparation of counting sources suitable for α -ray spectrometry.

A simple apparatus was devised for the rapid ion-exchange separation followed by the source preparation for α -ray spectrometry. It was suitable for various kinds of solvents, such as strong mineral acids, organic solvents and mixtures thereof, at temperatures up to 120°C and pressures up to 4 MPa.

The effect of temperature on adsorption behaviour was examined in nitric acid-methanol mixed media with anion-exchange resins at 30-90°C, over the boiling point of methanol at 1 atmosphere (0.1 MPa). Although the separation factor of the transplutonium and rare-earth elements decreased with increasing temperature, the number of theoretical plates in the ion-exchange separation increased considerably and the separation was improved at higher temperature. All rapid separations therefore have been performed at 90°C and at elevated pressure, since severe decomposition of resins did not take place below this temperature limit.

The first separation method was anion-exchange chromatography with nitric acid-methanol mixed media. The distribution coefficients and separation factors of Am, Cm and Cf at 90°C were determined as a function of the concentrations of acid and alcohol under dynamic conditions. The transplutonium elements could be separated from each other as well as from the target materials, i.e., U or Pu, and Al catcher foils.

The second method was anion-exchange chromatography with dilute hydrochloric acid-methanol mixed media. The behaviour of the transplutonium elements was similar to that with concentrated chloride solutions. Americium + Cm, Bk and Cf + Fm were rapidly separated from the target, catcher foils and major fission products. By a step gradient-elution technique, Bk or Cf + Fm was eluted with several drops of the eluent.

The third method was improved cation-exchange chromatography with single-column operation

using the mixed media of hydrochloric acid and methanol. After removal of large amounts of Al, Cu, Fe and/or U, and trace amounts of main fission products, the transplutonium elements were separated in a group from the rare-earth elements. The mutual separation of transplutonium elements with α -hydroxyisobutyrate eluent was also examined.

The separation methods developed were found applicable to studies on synthesis of the transplutonium nuclides, ^{250}Fm ($T_{1/2}$: 30 min), $^{244,245,246}\text{Cf}$ ($T_{1/2}$: 20 min, 46 min and 35.7 h, respectively) from the $^{16}\text{O} + ^{238}\text{U}$ and $^{12}\text{C} + ^{242}\text{Pu}$ reactions, and on the decay property of ^{245}Cf . Attempts to search for new actinide nuclides, such as ^{240}U and neutron deficient nuclides of Am, Cm and Bk, were made by a quick purification. The separation system was also applied to the rapid and effective separation of Nd, Am and Cm from spent nuclear fuel samples for burn-up determination.

By the use of the separation methods developed in this study, an on-line rapid ion-exchange system was designed. Finally, possible applications to other fields are described.

Keywords: Ion Exchange, Rapid Separation, α -Source Preparation, Transplutonium, Heavy-ion Reaction, Adsorption Behaviour, $\text{HNO}_3\text{-CH}_3\text{OH}$, $\text{HCl-CH}_3\text{OH}$, Elevated Temperature, Application

鉍酸-メタノール混合溶液を用いた超プルトニウム元素の 迅速イオン交換分離に関する研究

日本原子力研究所東海研究所燃料安全工学部

臼田重和

1988年10月4日受理

要 旨

重イオン核反応により生成する超プルトニウム元素は、 α 崩壊を伴う短寿命核種が多く、その生成量は極めて少ない。これらの核種を対象とした核化学的研究を行うには、高収率の迅速化学分離を行うとともにその α ソースを調製し、直ちに放射能測定をすることが必要である。

低粘度低沸点の有機溶媒、特にメタノールを溶離液として用いるイオン交換法は、高速溶離及び迅速 α ソース調製が可能であり、作成された α ソースは残渣の少ない良質のものとなる。しかし、室温中でこのような有機溶媒を用いるイオン交換分離は、一般にその平衡速度が極めて遅いので分解能が悪く、必ずしも実用的ではなかった。筆者は、簡単な加圧式イオン交換装置を考案し、小粒径のイオン交換樹脂と鉍酸-メタノール混合溶液を用いてメタノールの沸点を越える高温(90°C)で溶離操作を行うことにより、超プルトニウム元素の迅速分離を試みた。

硝酸-メタノール混合溶液を用いる陰イオン交換法は、超プルトニウム元素の相互分離ができる。室温中での吸着挙動はすでに研究されているが、温度によってその挙動は異なることがわかった。イオン交換樹脂が変質しない範囲で可能な限り高温(90°C)における吸着挙動を、酸濃度及びメタノール含量を関数として調べた。分配係数は、双方の濃度が高くなる程大きくなる。また、分離係数は硝酸よりメタノールの濃度効果が大きく、その含量が高くなる程大きくなる。これらの結果を基に、小容量カラム(25 μ l)を使用しても、適当な濃度の溶離液を選べば、超プルトニウム及び希土類元素の優れた迅速相互分離が達成されることを実証した。

塩酸-メタノール混合溶液を用いる陰イオン交換法では、超プルトニウム元素は1M酸濃度程度でもメタノール含有量が85%以上になると陰イオン交換樹脂に吸着することを見出した。この場合、超プルトニウム元素はクロロ錯体特有のイオン交換挙動を示し、Am+Cm, Bk, Cf+Fmの順に溶離する。分配係数は酸濃度及びアルコール含量とともに急激に増加し、また希土類元素との分離係数は、酸濃度とともに増大した。この系は、Al, U及び他の主な核分裂生成物との分離も可能であり、超プルトニウム元素の群分離に適する。

陽イオン交換法においては、有機溶媒を鉍酸溶離液に添加すると、超プルトニウム元素は樹脂にさらに強く吸着する。塩酸-メタノール混合溶液を用いると、多量のターゲット及びキャッチャー物質を容易に除去できるので分離の前処理として有用である。カラムに保持されている超プルトニウム元素を濃塩酸溶液を用いて希土類元素と属分離する方法、及び2-ヒドロキシ-2-メチルプロピオン酸溶液を用いて相互分離する方法を検討した。

いずれの方法も、超プルトニウム元素を迅速かつ効果的に分離した後、直ちに溶出液の液滴を直接蒸発乾固することにより、 α 線スペクトロメトリーに適した測定試料を調製することができた。また、2つの方法を組合せて、除染係数の高い超プルトニウム元素の精製を行うことにより、

その微弱な γ (X) 線放射能測定も可能となった。

これらの分離法を応用して、重イオン核反応 ($^{16}\text{O} + ^{238}\text{U}$ 及び $^{12}\text{C} + ^{242}\text{Pu}$ 反応) による短寿命超プルトニウム核種 (^{250}Fm , $^{244-246}\text{Cf}$ 等) の合成に関する研究, $^{12}\text{C} + ^{238}\text{U}$ 反応で生成する ^{245}Cf の崩壊特性に関する研究及びアクチノイド新核種の探索を行うとともに、使用済核燃料の燃料率測定のための分離法も開発した。

本研究で開発させたイオン交換分離法を有効に重イオン核反応に応用するため、オンライン化学分離装置を設計製作し、さらに短寿命の核種の研究を可能にした。本分離法は、環境中の超プルトニウム元素の分析等、他分野への応用も期待される。

CONTENTS

1. Introduction	1
1.1 Needs of rapid chemistry of the transplutonium elements	1
1.2 Conventional separation methods for the transplutonium elements	1
1.3 Use of mixed media of mineral acid and aqueous organic solvent as eluents at elevated temperature in ion-exchange-separation method	4
2. General Experimental Procedures	6
2.1 Pressurized ion-exchange-separation apparatus	6
2.1.1 Components of the apparatus	6
2.1.2 Operating procedures	8
2.1.3 Characteristics of the apparatus	8
2.2 Preparation of ion-exchange columns	9
2.3 Preparation of mixed eluents of mineral acid and methanol	10
2.4 Preparation of tracers	11
2.4.1 Short-lived transplutonium tracers synthesized by an accelerator	11
2.4.2 Long-lived transplutonium and other tracers prepared by a reactor	11
2.5 Radioactivity measurements	11
2.6 Definition of distribution coefficient, separation factor, number of theoretical plates and resolution	12
3. Anion-Exchange Separation with the Mixed Media of Nitric Acid and Methanol at Elevated Temperature	13
3.1 Introduction	13
3.2 Effect of temperature on adsorption	13
3.3 Dependence of the distribution coefficient and the relative separation factor on nitric acid concentration	16
3.4 Dependence of the distribution coefficient and the relative separation factor on methanol content	17
3.5 Adsorption behaviour in mixed media of other organic solvents	19
3.6 Alpha-source preparation	21
3.7 Separation procedures	22
3.7.1 Rapid separation of Am, Cm and Cf	22
3.7.2 Rapid separation of ^{246}Cf and ^{250}Fm	25
3.7.3 Rapid mutual-separation of the light lanthanoids	27
3.7.4 Rapid separation of Bk from Ce	30
4. Anion-Exchange Separation with the Mixed Media of Hydrochloric Acid and Methanol at Elevated Temperature	31
4.1 Introduction	31
4.2 Adsorption of the transplutonium elements in mixtures of hydrochloric acid and methanol	32
4.3 Effect of hydrochloric acid concentration	33
4.4 Effect of methanol content	34
4.5 Adsorption behaviour in mixed media of other organic solvents	35
4.6 Separation procedures	36

4.6.1 Rapid separation of Cf and its α -counting source preparation	36
4.6.2 Rapid separation of Bk	38
4.6.3 Rapid separation of Fm	40
5. Cation-Exchange Separation with the Mixed Media of Hydrochloric Acid and Methanol at Elevated Temperature (for Pre-Separation)	42
5.1 Introduction	42
5.2 Effective removal of uranium target, catcher-foil material and main fission products	42
5.3 Group or mutual separation of the transplutonium elements	44
5.4 Rapid separation of the transplutonium nuclides from heavy-ion bombarded uranium targets	47
6. Application of the Separation System	49
6.1 Synthesis of short-lived actinide nuclides by heavy-ion reactions	49
6.1.1 Actinide nuclides synthesized by the $^{16}\text{O} + ^{238}\text{U}$ reaction	49
6.1.2 Transplutonium nuclides synthesized by the $^{12}\text{C} + ^{242}\text{Pu}$ reaction	57
6.2 Decay property of ^{245}Cf	60
6.3 Search for new actinide nuclides	65
6.4 Burn-up determination of spent nuclear fuels	69
6.4.1 Separation of Nd for IDM determination	69
6.4.2 Quantitative separation of Nd, Am and Cm	71
6.4.3 Rapid separation of Nd, U, Pu, Am and Cm	74
6.5 System design for on-line rapid ion-exchange separation	76
7. Conclusions	78
Acknowledgements	79
Appendix A Instruction Manual for the Pressurized Ion-Exchange-Separation Apparatus	80
Appendix B Ion-Exchange Separation of the Actinide Elements with Mineral Acid Eluents Using the Pressurized Ion-Exchange-Separation Apparatus	82
References	86

List of Tables, Figures and Photographs

1. List of Tables

- Table 1.1 Oxidation states of actinoids.
- Table 1.2 Electronic configuration and ionic radii of 5f-block atoms and their 3+ ions.
- Table 1.3 Physical properties of water and selected water-miscible solvents.
- Table 2.1 Ion-exchange resins used in this work.
- Table 2.2 Dimensions of columns.
- Table 3.1 Separation data for selected solvent-aqueous systems (10% 5 M HNO₃-90% solvent) at ambient temperature.
- Table 3.2 Comparison of number of theoretical plates (*N*) and resolutions (*R*) with different flow rates.
- Table 3.3 Distribution coefficients (*K_d*) and separation factors (*α*) of the transplutonium elements in HNO₃-CH₃OH media at 90°C.
- Table 3.4 Separation factors relative to Nd.
- Table 3.5 Resolutions of mutual separation among the light lanthanoid and transplutonium elements.
- Table 4.1 Distribution coefficients (*K_d*) and separation factors (*α*) for Am(III) and Yb(III) in various organic solvents (75%) mixed with concentrated hydrochloric acid (25%) on Dowex 1 X8 resin at ambient temperature.
- Table 4.2 Distribution coefficients (*K_d*) and separation factors (*α*) of the transplutonium elements in 0.5 M HCl-90% CH₃OH medium at 90°C.
- Table 6.1 Decay properties of ²⁴⁵Cf.
- Table 6.2 Predicted nuclear properties of some selected actinide nuclides.
- Table 6.3 Separation factors relative to Nd.

2. List of Figures.

- Fig. 1.1 Influence of temperature on viscosity of selected liquids.
- Fig. 2.1 Arrangement of pressurized ion-exchange-separation apparatus.
- Fig. 2.2 Diagram of ion-exchange column.
- Fig. 3.1 Temperature effect on the separation factors expressed relative to Cm (*S_{Cm}*:1, *K_{dCm}*:90±10).
- Fig. 3.2 Number of theoretical plates of some elements vs temperature.
- Fig. 3.3 Effect of temperature on the resolution.
- Fig. 3.4 Elution curves for rapid anion-exchange separation of the transplutonium elements from large amounts of U with HNO₃-CH₃OH mixed media at room temperature.
- Fig. 3.5 Elution curves for rapid anion-exchange separation of the transplutonium and rare-earth elements from about 2 mg of Al and U with HNO₃-CH₃OH mixed media at 90°C.
- Fig. 3.6 Dependence of the distribution coefficients on acidity at constant alcohol content.
- Fig. 3.7 Dependence of the separation factors expressed relative to Cm on acidity at constant alcohol content.
- Fig. 3.8 Influence of methanol content on the distribution coefficients at constant acidity.

- Fig. 3.9 Effect of methanol content on the separation factors expressed relative to Cm at constant acidity.
- Fig. 3.10 Distribution coefficients of U, Am, Cm and Cf on the anion-exchange resin in HNO_3 - CH_3OH media at 90°C .
- Fig. 3.11 Distribution coefficients of Sr, Y, Eu, Pm and Ce on the anion-exchange resin in HNO_3 - CH_3OH media at 90°C .
- Fig. 3.12 Anion-exchange chromatogram of the transplutonium and rare-earth elements from about 5 mg of Al and U with nitric acid-acetone mixed media at 90°C .
- Fig. 3.13 Anion-exchange chromatogram of the transplutonium and rare-earth elements with nitric acid-methanol mixed media at 90°C .
- Fig. 3.14 Comparison of the anion-exchange distribution coefficients in methanol and acetone.
- Fig. 3.15 Typical α -ray spectra of Cf, Cm and Am fractions.
- Fig. 3.16 Typical chromatogram of the transplutonium and some other elements.
- Fig. 3.17 Chromatogram of the transplutonium and some other elements at higher flow rate.
- Fig. 3.18 Elution curves for rapid anion-exchange separation of the transplutonium and rare-earth elements from macro amounts of Al and U by the acidity-step gradient method.
- Fig. 3.19 Anion-exchange chromatogram of ^{250}Fm and ^{246}Cf with 1 M HNO_3 -95% CH_3OH mixed medium.
- Fig. 3.20 Diagram for rapid mutual-separation of the actinide elements.
- Fig. 3.21 Alpha-ray spectra of each actinide fraction separated by anion exchange with HNO_3 - CH_3OH mixed media.
- Fig. 3.22 Anion-exchange chromatogram for rapid separation of the light lanthanoids from the irradiated uranium sample with 0.01 M HNO_3 -90% CH_3OH medium at 90°C .
- Fig. 3.23 Anion-exchange chromatogram for rapid separation of the light lanthanoids from the irradiated uranium sample with 0.5 M HNO_3 -80% CH_3OH medium at 90°C .
- Fig. 3.24 Anion-exchange separation of Bk from Ce with HNO_3 - CH_3OH system.
- Fig. 4.1 Typical anion-exchange chromatogram of the transplutonium and rare-earth elements with 0.5 M HCl -90% CH_3OH mixed medium at 90°C and about 7.5 cm/min.
- Fig. 4.2 Influence of hydrochloric acid concentration on the anion-exchange distribution coefficients of the transplutonium elements with solutions containing 90% CH_3OH .
- Fig. 4.3 Separation factors of rare earths, Am, Bk, Cf and Fm relative to Cm for anion exchange in hydrochloric acid solutions containing 90% CH_3OH at 90°C .
- Fig. 4.4 Dependence of the anion-exchange distribution coefficients of the transplutonium elements on the alcohol content in solutions of 0.5 and 1 M HCl .
- Fig. 4.5 Comparison of the anion-exchange distribution coefficients in CH_3OH and $\text{C}_2\text{H}_5\text{OH}$.
- Fig. 4.6 Separation of Cf from Am + Cm, main FP, Al (6 mg) and U (5 mg) with HCl -alcohol media at 90°C .
- Fig. 4.7 Alpha-ray spectrum of the Cf fraction.
- Fig. 4.8 Elution curves for anion-exchange separation of Bk with HCl - CH_3OH medium at 90°C from an aluminium-catcher foil after irradiation.
- Fig. 4.9 Flow diagram for rapid separation of Bk from an aluminium-catcher foil.
- Fig. 4.10 X-ray spectrum of the Bk fraction separated by anion exchange with HCl - CH_3OH media at 90°C .
- Fig. 4.11 Elution curves of the actinide nuclides produced by the $^{12}\text{C}+^{242}\text{Pu}$ reaction with anion exchange in 0.5 M HCl -90% CH_3OH medium.
- Fig. 5.1 Comparison of the distribution coefficients for cation-exchange resins with selected eluents.
- Fig. 5.2 Cation-exchange chromatogram for separation of the transplutonium elements from fission products and a copper foil.

- Fig. 5.3 Cation-exchange chromatogram for group separation of transplutonium and rare-earth elements from a uranium target and an aluminium foil.
- Fig. 5.4 Cation-exchange chromatogram for mutual separation of the transplutonium elements from fission products and a uranium target.
- Fig. 5.5 Flow diagram for mutual separation of transplutonium elements from a heavy-ion bombarded uranium target with an aluminium foil by single cation-exchange column.
- Fig. 5.6 Flow diagram for rapid group-separation of transplutonium elements.
- Fig. 5.7 Alpha-ray spectrum of the transplutonium fraction separated from a ^{16}O bombarded ^{238}U target by the cation-exchange method.
- Fig. 6.1 ^{238}U target assembly.
- Fig. 6.2 Typical α -ray spectra of an aluminium-catcher foil after the bombardments of ^{238}U target with 92 MeV ^{16}O beams.
- Fig. 6.3 Diagram for rapid anion-exchange separation of Am + Cm and Cf + Fm from target material (U or Pu) and an aluminium-catcher foil with HCl-CH₃OH media.
- Fig. 6.4 Typical α -ray spectrum of the Cf + Fm fraction purified by anion-exchange method with HCl-CH₃OH media.
- Fig. 6.5 Decay curve of 7.4-MeV α emitter in the transplutonium fraction after ion-exchange separation.
- Fig. 6.6 Elution curves of ^{16}O bombarded ^{238}U target by the anion-exchange method with HNO₃-CH₃OH media.
- Fig. 6.7 Separation procedures for Th and transplutonium elements from a uranium target and an aluminium-catcher foil using the anion-exchange method with HCl-CH₃OH media.
- Fig. 6.8 Typical α -ray spectrum of the actinide fraction purified by the anion-exchange method with HCl-CH₃OH media, observed immediately following separation (about 20 min after irradiation).
- Fig. 6.9 Alpha-ray spectrum of the same actinide fraction observed in long counting duration, 7.4 d after irradiation.
- Fig. 6.10 Excitation function of the reaction $^{238}\text{U} (^{16}\text{O}, 4n) ^{250}\text{Fm}$.
- Fig. 6.11 Excitation functions of the $^{16}\text{O} + ^{238}\text{U}$ reaction.
- Fig. 6.12 Formation-cross sections of thorium, actinium and radium nuclides synthesized by the $^{16}\text{O} + ^{238}\text{U}$ reaction.
- Fig. 6.13 Typical α -ray spectrum of an aluminium-catcher foil which caught the recoil nuclei produced by the $^{12}\text{C} + ^{242}\text{Pu}$ reaction.
- Fig. 6.14 Typical α -ray spectrum of the transplutonium fraction purified by the cation-exchange method.
- Fig. 6.15 Excitation functions for ^{250}Fm produced by the $^{12}\text{C} + ^{242}\text{Pu}$ (left side) and the $^{16}\text{O} + ^{238}\text{U}$ (right side) reactions.
- Fig. 6.16 Excitation functions for ^{244}Cf , ^{245}Cf and ^{246}Cf produced by the $^{12}\text{C} + ^{242}\text{Pu}$ (left side) and the $^{16}\text{O} + ^{238}\text{U}$ (right side) reactions.
- Fig. 6.17 Excitation functions for ^{242}Cm (^{242}Am) and $^{243,244}\text{Cm}$ produced by the $^{12}\text{C} + ^{242}\text{Pu}$ (left side) and the $^{16}\text{O} + ^{238}\text{U}$ (right side) reactions.
- Fig. 6.18 Excitation functions for ^{244}Cf , ^{245}Cf and ^{246}Cf produced by the $^{12}\text{C} + ^{238}\text{U}$ reaction.
- Fig. 6.19 Alpha-ray spectrum of the Cf fraction separated by the anion-exchange method with HCl-CH₃OH media at elevated temperature.
- Fig. 6.20 Decay curve of ^{245}Cf .
- Fig. 6.21 Gamma-ray spectrum of the Cf fraction purified by the anion-exchange method with HCl-CH₃OH media after ^{245}Cf was decayed to ^{245}Bk .
- Fig. 6.22 Californium purification procedure- I (for γ -ray spectrometry).

- Fig. 6.23 Californium purification procedure-II (for γ -ray spectrometry).
- Fig. 6.24 Gamma-ray spectrum of the Cf fraction purified by procedure-II after ^{245}Cf decayed to ^{245}Bk .
- Fig. 6.25 Anion-exchange separation of Np and U from Al, fission products and transplutonium elements with hydrochloric acid and methanol solutions at 90°C .
- Fig. 6.26 Purification procedures for Am and Cm.
- Fig. 6.27 Excitation functions for $^{238-242}\text{Cf}$ and $^{235-239}\text{Cm}$ in the $^{12}\text{C}-^{233}\text{U}$ reaction calculated with the code ALICE.
- Fig. 6.28 Excitation functions for $^{239-245}\text{Bk}$ in the $^4\text{He} + ^{241}\text{Am}$ reaction calculated with the code ALICE.
- Fig. 6.29 Separation of Nd, Am and Cm on conventional anion-exchange resin at ambient temperature and pressure.
- Fig. 6.30 Procedure I (separation of Nd for IDM determination).
- Fig. 6.31 Typical elution curves for separation of a 40 GWd/t burn-up spent fuel specimen based on Procedure I.
- Fig. 6.32 Quantitative separation of Nd, Am and Cm on fine anion-exchange resin at ambient temperature and pressure.
- Fig. 6.33 Gamma-ray spectrum of ^{147}Nd in the Nd fraction.
- Fig. 6.34 Procedure II (quantitative separation of Nd, Am and Cm in spent nuclear fuels).
- Fig. 6.35 Rapid initial-separation of irradiated U with anion exchange in HNO_3 solution at ambient temperature and elevated pressure.
- Fig. 6.36 Rapid separation of Nd, Am and Cm with anion exchange in $\text{HNO}_3\text{-CH}_3\text{OH}$ media at 90°C .
- Fig. 6.37 Procedure III (rapid separation of Nd, U, Pu, Am and Cm in spent nuclear fuels).
- Fig. 6.38 Block diagram of on-line rapid ion-exchange separation system.
- Fig. 6.39 Block diagram of on-line rapid chemical separation system.
- Fig. A.1 Anion-exchange separation of the actinide elements with hydrochloric acid solutions containing other selected mineral acids at room temperature.
- Fig. A.2 Cation-exchange separation of the transplutonium elements from a mixture of fission products, uranium (1.1 mg) and an aluminium foil (3.2 mg) with hydrochloric acid solutions.
- Fig. A.3 Flow diagram for the rapid ion-exchange separation of transplutonium elements from a heavy-ion bombarded uranium target with an aluminium foil.
- Fig. A.4 Alpha-ray spectrum of the transplutonium fraction after the ion-exchange separation.

3. List of Photographs.

- Photo. 1 Reservoir for sample solution and eluents.
- Photo. 2 Ion-exchange column in a thermostatically controlled air box.
- Photo. 3 Monitor for γ or β radioactivity: a well-type NaI detector (right) and an NA102A tube detector (left).
- Photo. 4 Evaporator for effluent and a fraction collector.
- Photo. 5 Prepared ion-exchange column.
- Photo. 6 Resin reservoir for column preparation.

1. Introduction

1.1 Needs of rapid chemistry of the transplutonium elements

The transplutonium-actinide elements are composed of those of atomic number 95 through 103; americium (Am), curium (Cm), berkelium (Bk), californium (Cf), einsteinium (Es), fermium (Fm), mendelevium (Md), nobelium (No) and lawrencium (Lr). Those elements are all artificially synthesized. Only a limited number of nuclides of the elements (Am to Fm) are produced in weighable quantities by multiple neutron capture with an intense neutron flux in a nuclear reactor [Tac 79, Mad 86]. The majority of transplutonium nuclides identified so far are synthesized in trace quantities by charged particle bombardment of isotopes of heavy elements using an accelerator.

These transplutonium nuclides are of short half-life and often emit α particles. The production yields of the nuclides are quite low, mainly because of their small formation-cross sections. When those nuclides are synthesized, fission and side-reaction products generate large quantities of radioactivity, which may interfere with the detection and identification of the nuclides under investigation.

In recent years interest in the nuclear properties of the transplutonium elements has increased. The decay properties of many short-lived nuclides have not been determined yet. Investigation of details of the decay properties, such as α decay and spontaneous fission, gives valuable information to elucidate their nuclear structures. Quite recently a new form of radioactive decay has been reported; nuclei heavier than Pb spontaneously emit particles heavier than α particles but lighter than fission fragments [Ros 84, Kut 85, Bar 85, Ahm 86, Moo 87b, Wan 87]. Chemistry of the transplutonium elements is also of interest from the viewpoint of studying 5f electron configurations.

In order to study the chemistry and nuclear chemistry of the short-lived transplutonium nuclides, it is essential to develop selective chemical separation procedures with high and consistent yields for rapid purification of those elements and to prepare quickly counting sources suitable for α -ray spectrometry. The aim of this study is to establish rapid and quantitative separation methods for the transplutonium nuclides, half-life of which is from several minutes to about one hour, and to develop a technique for immediate preparation of α source within ten minutes.

1.2 Conventional separation methods of the transplutonium elements

The transplutonium elements (Am to Lr), the heavier elements in the actinide series, are those in which the 5f-electron shells are being completed and the chemical properties are similar to those of the lanthanoids. **Table 1.1** shows stable oxidation states of the actinoids [Leb 82, Mya 83, Kat 86]. Except for No, the transplutonium elements are stable in the $3+$ oxidation state in aqueous solutions in the absence of an oxidizing or reducing agent. The most stable oxidation state of No in an aqueous solution is $2+$ [Mal 68, Sil 69, Sil 74].

Although the chemical properties of the tri-valent transplutonium elements are almost identical, there are slight quantitative differences due to actinide contraction, i. e., a significant and steady decrease in the size of the atoms and ions as atomic numbers increase. **Table 1.2** lists the electronic configuration and ionic radii of 5f-block atoms and their $3+$ ions [Mil 83a, Kat 86, Dav 86].

Separation of the transplutonium elements has two problems: (1) separation of the transplutonium elements in a group from the lanthanoids, which are always produced as fission fragments by the bombardment in the synthesis of transplutonium nuclides, and (2) separation of the transplutonium

elements from one another.

Group separation can be performed by a cation- or anion-exchange method with concentrated hydrochloric acid [Str 50, Dia 54, Tho 54, Cho 60, Cho 62, Ume 74], 20% ethanol saturated with hydrogen chloride [Tho 54, Smi 56] or thiocyanate solution [Sur 57, Col 69] as an eluting agent. Since the transplutonium ions form complexes with chloride and thiocyanate ions easily, they are first desorbed from cation-exchange resins. Conversely the transplutonium ions are more strongly adsorbed on anion-exchange resins. Separation was effective with 10 M lithium chloride as eluent for the anion-exchange column [Hul 61].

Table 1.1 Oxidation states of actinoids [Leb 82, Mya 83, Kat 86].

Atomic number	89	90	91	92	93	94	95	96	97	98	99	100	101	102	103
Element	Ac	Th	Pa	U	Np	Pu	Am	Cm	Bk	Cf	Es	Fm	Md	No	Lr
Oxidation states	3	[3]	[3]	[3]	(3)	(3)	3	3	3	3	3	3	3	(3)	3
		4	(4)	(4)	(4)	4	(4)	[4]	(4)	[4]	[4]				
			5	[5]	5	(5)	(5)			[5]					
				6	(6)	(6)	(6)	[6]							
				[7]	[7]	[7]									

Bold type : the most stable oxidation state in aqueous solutions;

() : relatively stable in aqueous solutions, may be used for analytical purposes;

[] : unstable oxidation state, exists under special conditions, is produced by special methods or is known only in solid compounds.

Table 1.2 Electronic configuration and ionic radii of 5f-block atoms and their 3+ ions.

Element	Electronic configuration		Ionic radii of M^{3+} ($10^{-10}m$)			
	Gaseous atom	M^{3+} (g)	Ref. [Bur 73]	Ref. [Sha 76]	Ref. [Mik 83a]	Ref. [Dav 86]
Ac	6d7s ²		1.119	1.12		1.12
Th	6d ² 7s ²	5f	-	-		1.08
Pa	5f ² 6d7s ²	5f ²	-	-		1.05
U	5f ³ 6d7s ²	5f ³	1.041	1.025		1.028
Np	5f ⁴ 6d7s ²	5f ⁴	1.017	1.01		1.011
Pu	5f ⁶ 7s ²	5f ⁵	0.997	1.00		0.995
Am	5f ⁷ 7s ²	5f ⁶	0.982	0.975		0.980
Cm	5f ⁷ 6d7s ²	5f ⁷	0.970	0.97		0.970
Bk	5f ⁹ 7s ²	5f ⁸	0.949	0.96		0.955
Cf	5f ¹⁰ 7s ²	5f ⁹	0.934	0.95		0.945
Es	5f ¹¹ 7s ²	5f ¹⁰	0.925	-	0.94	0.934
Fm	(5f ¹² 7s ²)	(5f ¹¹)	-	-	0.94(0.93)	0.922
Md	(5f ¹³ 7s ²)	(5f ¹²)	-	-	0.92	0.912
No	(5f ¹⁴ 7s ²)	(5f ¹³)	-	-	0.91	0.902
Lr	(5f ¹⁴ 6d7s ² or 5f ¹⁴ 7s ² 7p)	(5f ¹⁴)	-	-	-	0.896

Intragroup separation can be accomplished by chromatographic methods, such as ion-exchange and extraction chromatographies. The methods utilize the very small difference in their chemical properties to give a useful separation factor for the tri-valent actinide elements, being multistage separation being employed. Early ion-exchange methods used a cation-exchange resin and citrate or lactate as an eluting agent [Tho 54, Ghi 55b, Kat 57]. Later, α -hydroxyisobutyrate (2-hydroxy-2-methylpropionate) was used by Choppin et al. [Cho 56a]. The latter is still in use today as the most efficient eluent of the transplutonium and rare-earth elements [Ghi 55a, Smi 56, Mil 56, Cho 56b, Fie 57, Ghi 58, Gat 59, Fuj 63, Spe 69, Cam 70a, Cam 70b, Nat 71, Sis 72, Cam 73, Ele 79, Pim 82, Nik 82, Moo 83, Kul 85, Ele 86, Vob 86, Mik 87, Duf 88]. The ion-exchange method has been used for rapid isolation of the transplutonium elements.

Extraction chromatography with a column using bis (2-ethylhexyl) orthophosphoric acid (D2EHPA) as the stationary phase has been studied by many workers [Gav 66, Hor 67, Hor 69a, Hor 69b, Hor 73, Hor 74, Hor 75, Sch 78, Nik 82, Fed 86, Kas 87]. The major difference between the ion-exchange and extraction chromatographies is a reversal of the elution sequence with atomic number.

In addition, electromigration with α -hydroxyisobutyrate [Buc 65, Buc 70] and a thermo-chromatographic technique using titanium and molybdenum columns [Chu 69, Hüb 80, Zva 81, Hüb 82, Fed 87] have also been reported.

Separation based on oxidation and reduction is also useful to separate the transplutonium elements from one another. Berkelium can be oxidized to the 4+ state under conditions equivalent to those required for oxidation of Ce^{3+} to Ce^{4+} , so that Bk^{4+} coprecipitates with zirconium phosphate [Tho 54], zirconium iodate [Tho 54], ceric iodate [Tho 54, Far 69, Wea 68], and insoluble hydroxides [Tho 54]. Rapid extraction of Bk^{4+} into D2EHPA-heptane from the tripositive actinoids is also possible in nitric acid solution [Pep 57, Kos 77, Eri 79, Liu 81, Liu 83, Yak 83]. Separation based on the reduction of Md to the 2+ state followed by isolation using solvent extraction with D2EHPA has also been reported [Hul 79, Lun 81]. Recently, Mikheev et al. have reported co-crystallization of reduced Fm and Md with sodium chloride in aqueous ethanol solution containing Eu^{2+} and Yb^{2+} , respectively [Mik 81, Mik 83b, Kam 85].

High pressure liquid chromatography has been often applied to high speed separation of the transplutonium elements [Cam 70a, Cam 70b, Low 71, Sis 72, Cam 73, Hor 74, Tak 75, Hor 77, Sch 77, Sch 78, Bak 81, Liu 81, Pim 82, Bak 82, Liu 83, Duf 88]. The method must be performed at high pressure to force eluents through a column packed with very fine particles as a stationary phase.

The SISAK* technique, which is an on-line solvent-extraction separation system, is suited for studies of short-lived nuclides by γ - and X-ray activity measurements [Ska 80, Növ 81, Bro 81, Bro 82, Ska 83]. New neutron-rich neptunium isotopes, ^{243}Np and ^{244}Np , were isolated with reduction-oxidation procedures by the use of this technique [Tet 86, Moo 87a].

Many separation methods for transplutonium elements have been reported and reviewed in the literature [Kat 57, Hig 60, Pen 60, Sam 63, Kor 66a, Kor 69, Hul 72, Spi 76, Nav 80, Mya 83, Cho 84, Kat 86, Fow 86, Tür 88, Usu 88c].

With the separation methods and techniques described above, it is difficult to prepare a counting source suitable for α -ray spectrometry. The source preparation usually requires much time to evaporate the solvent or to decompose the organic solute and needs additional steps when some residue remains on the counting disk.

* : Short-lived Isotopes Studied by the AKUFVE technique; AKUFVE is an abbreviation of Swedish words for a system of rapid and accurate measurement of partition coefficients in solvent extraction.

1.3 Use of mixed media of mineral acid and aqueous organic solvent as eluents at elevated temperature in ion-exchange-separation method

Of various chemical separation methods for the transplutonium elements, an ion-exchange method was selected for this study. The reasons are as follows:

- 1) Both the group separation of the transplutonium elements from the lanthanoids and the intragroup separation of individual actinide elements can be done rapidly.
- 2) The element in question can be concentrated in a small volume of effluent. This fact facilitates an easy preparation of α -counting sources. It is essential to prepare a salt-free counting source that allows high resolution α spectroscopy for detailed studies of α transitions in transplutonium nuclides, and for avoidance of any interference from α rays emitted from other nuclides.
- 3) Trace amounts of transplutonium elements can be quantitatively separated.
- 4) The procedures are so simple that they can be automatically repeated with a continuous on-line separation system.

For rapid separation and immediate source preparation of the transplutonium elements, it is beneficial to use a water-miscible organic solvent with a low boiling point and low viscosity as eluent.

The physical properties of some typical water-miscible organic solvents are compared with that of water in **Table 1.3** [Mar 69]. Methanol and acetone are most suited for performing separations at a high flow-rate and for immediate source preparation. Methanol or acetone lowers the viscosity and thus flow resistance. The evaporation rate at the time of source preparation is increased due to the low boiling point, thus resulting in minimum evaporation residue. In addition, hydration is repressed with decreasing dielectric constant of the organic solvent, giving rise to the increased interaction of the metallic ions with ligands. Thus, formation of complexes can be promoted [Kor 66b, Str 73].

The use of mixed eluents of organic solvent and mineral acid for ion-exchange separation has long drawn considerable attention. It is well-known that the replacement of part of the aqueous phase by an organic solvent very often enhances the ion-exchange adsorbabilities of metallic ions. In addition, the adsorption selectivity of a given pair of ions often becomes high [Kor 66b, Moo 68, Str 73, Kur 79].

However, the ion-exchange separation with eluents containing organic solvents has been performed only at ambient temperature. If rapid separation is carried out at ambient temperature, enlarged peak widths and serious tailings are observed in the elution curve. This is caused by slow attainment of the ion-exchange equilibrium in mixed organic solvent-mineral acid eluents at ambient temperature.

Table 1.3 Physical properties of water and selected water-miscible solvents [Mar 69]

Solvent	M.wt.	Boiling point (°C)	Density (g/cm ³)	Viscosity (mPa.s)	Dielectric constant
Water	18.0	100.0	0.997	0.895	78.36
Methanol	32.0	64.5	0.787	0.55	32.6
Ethanol	46.1	78.3	0.785	1.08	24.3
1-Propanol	60.1	97.2	0.804	2.3	22.2
2-Propanol	60.1	82.4	0.786	2.08	13.8
1-Butanol	74.1	117.7	0.81	2.46	16.1
2-Methyl-1-propanol	74.1	108.0	0.81	3.90	17.9
2-Butanol	74.1	99.5	0.81	4.21	15.8
2-Methyl-2-propanol	74.1	82.5	0.783	3.32*	
Acetone	58.1	56.2	0.785	0.30	20.7
1,4-Dioxane	88.1	101.3	1.036	1.2	2.24
Dimethyl sulphoxide	78.1	189	1.096	1.96	46.6

All values valid for 25°C, except that marked "*", valid for 40°C.

To remove those difficulties, the rapid ion-exchange separation using the organic solvent should be performed at elevated temperature, even above the boiling point of the organic solvent at 1 atmospheric pressure. But, caution must be taken to prevent decomposition of the ion-exchange resins in the column with heat.

The merits of working at an elevated temperature are as follows [Tho. 54, Sam 63]: First, the diffusion rate may be increased. Therefore, the number of theoretical plates increases with temperature and more effective separation can be expected. Another advantage is that the flow resistance is decreased because the viscosity of the liquid is reduced with an increase in temperature. **Figure 1.1** shows the influence of temperature upon the viscosity of water, methanol, ethanol, 2-propanol and acetone [KAG 84]. Other advantages which may be gained by operating at elevated temperature are the reduction of non-ionic adsorption forces and a more rapid establishment of ion-exchange equilibria.

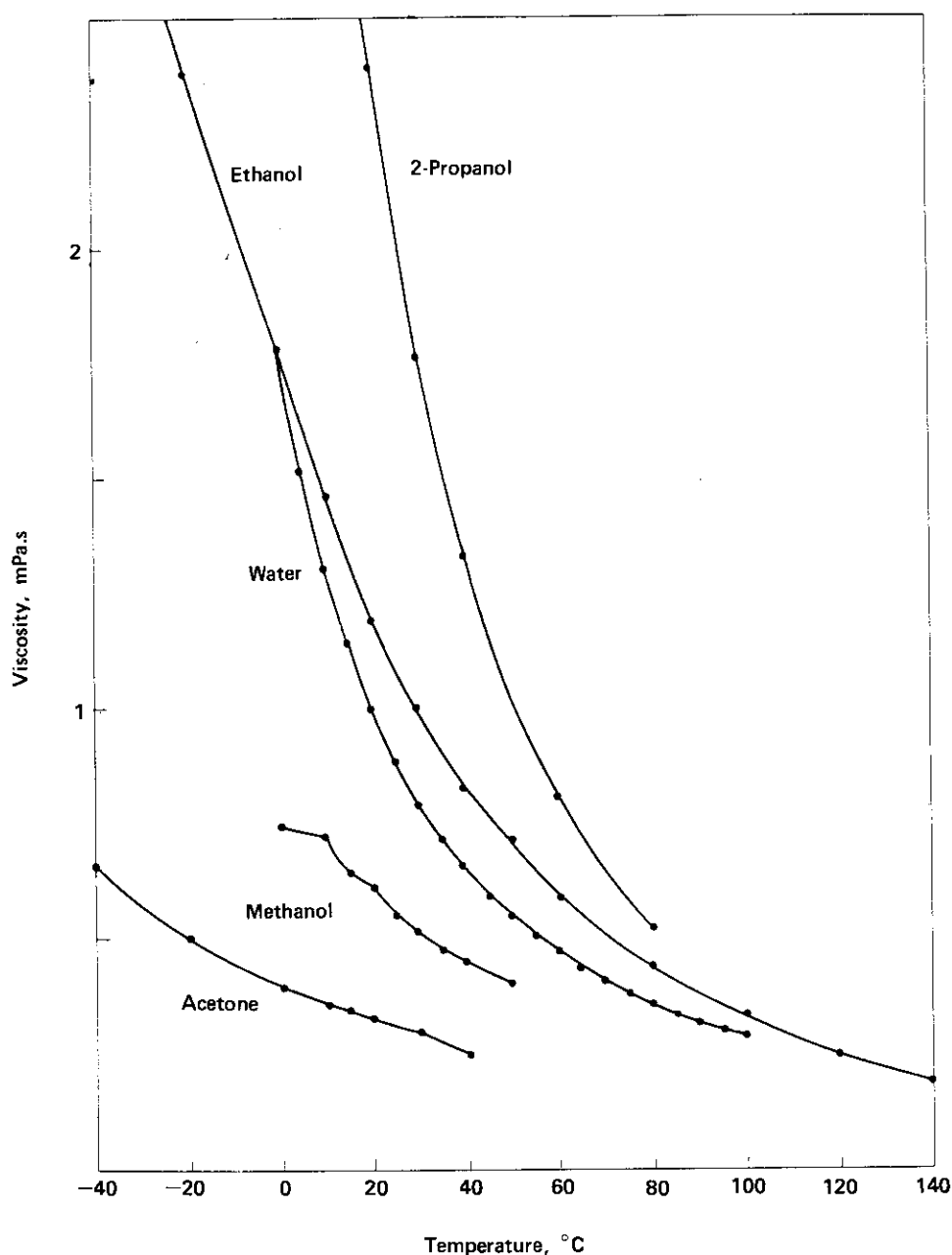

Fig. 1.1 Influence of temperature on viscosity of selected liquids [KAG 84].

2. General Experimental Procedures

2.1 Pressurized ion-exchange-separation apparatus

A simple pressurized ion-exchange-separation apparatus has been devised. The apparatus is suitable for use with many kinds of solvents such as strong mineral acids, organic solvents and their mixtures at a higher temperature and pressure [Usu 87a, Usu 87b]. When salt-free solutions are used as eluents, dropwise quantities of effluents can be directly evaporated on a counting disk to prepare samples for the α counting

2.1.1 Components of the apparatus

The pressurized ion-exchange separation apparatus is schematically shown in **Fig. 2.1**. The apparatus was composed of the following components:

- 1) Eluent flow rate controller (a nitrogen-gas cylinder, a pressure-control valve and a 3-way valve made of Teflon)

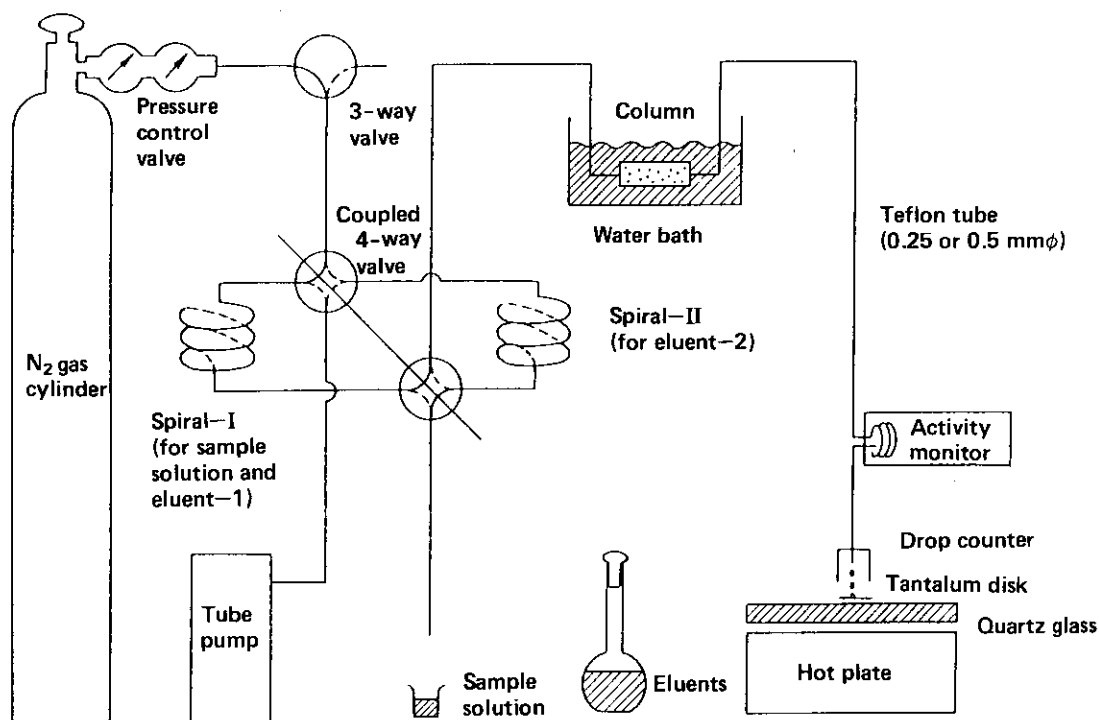

Fig. 2.1 Arrangement of pressurized ion-exchange-separation apparatus.

- 2) Eluent and sample solution reservoir (a coupled 4-way valve made of Teflon, two spiral Teflon tubes (i.d.: 2 mm, volume: ca. 10 ml) and a tube pump for drawing the solution; see **Photo. 1**)
- 3) Ion exchange separator (a column and a thermostatically controlled water-bath or air-bath; see **Photo. 2**)
- 4) Monitor, if necessary, for γ or β radioactivity (a well-type NaI(Tl) scintillation detector or an

NA102A plastic scintillation-tube detector; see **Photo. 3**)

- 5) Effluent evaporator (a hot plate with quartz glass and, if necessary, a fraction collector with a drop counter; see **Photo. 4**)

All parts were connected with Teflon tubes (i.d.: 0.25 or 0.5 mm). An attached graduated eluent reservoir could be used instead of a spiral tube. Setup instructions for the apparatus are included in Appendix A.1.

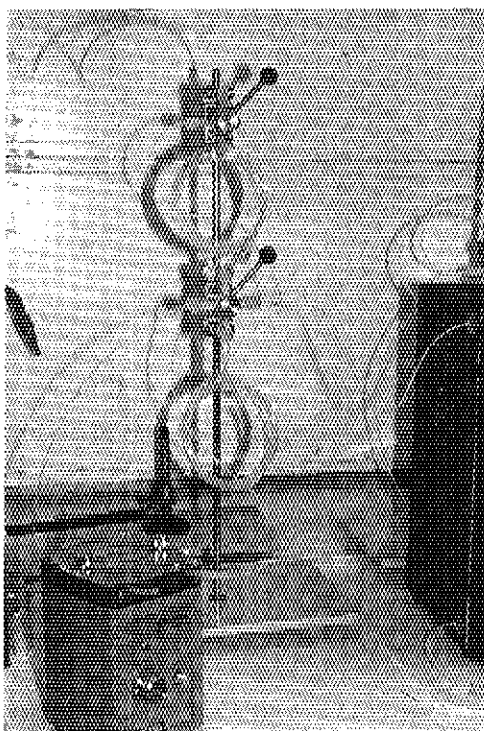

Photo. 1 Reservoir for sample solution and eluents.

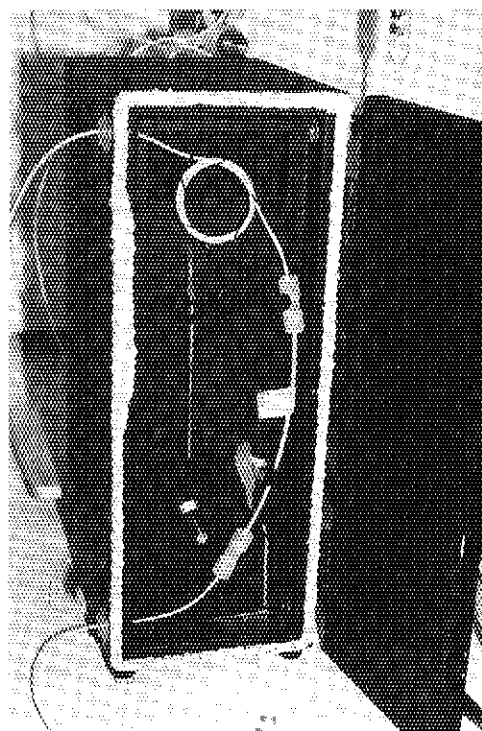

Photo. 2 Ion-exchange column in a thermostatically controlled air box.

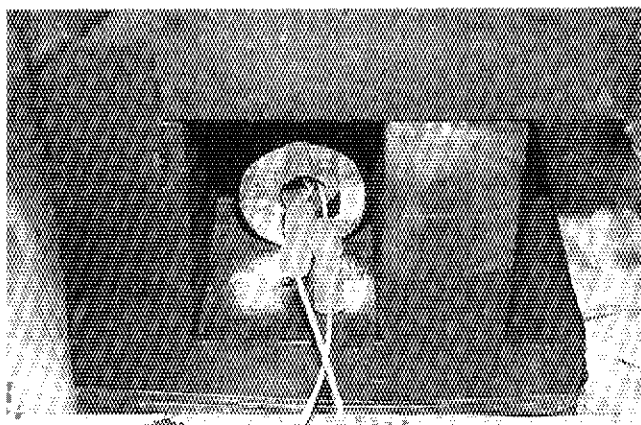

Photo. 3 Monitor for γ or β radioactivity: a well-type NaI detector (right) and an NA102A tube detector (left).

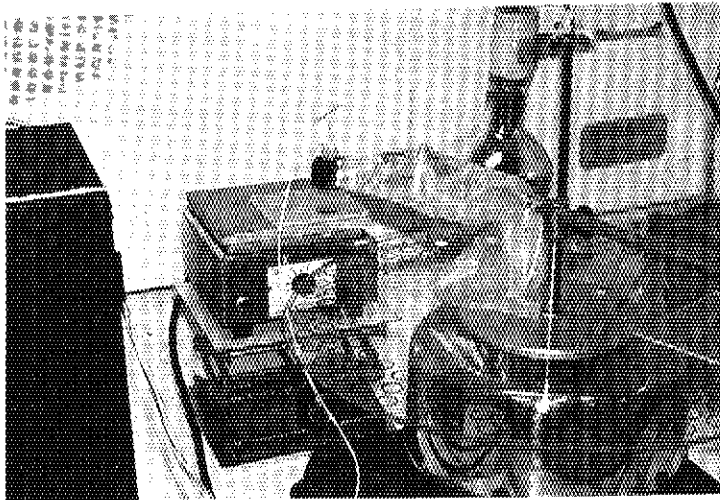

Photo. 4 Evaporator for effluent and a fraction collector.

2.1.2 Operating procedures

After preparation of the sample solution, the separation of elements in question was performed as follows:

- 1) A measured volume of the first eluent was drawn into spiral tube-I by the tube pump. The sample solution was then drawn into the same spiral tube. A small volume of air was intentionally placed between two solutions to prevent the mixing of the solutions.
- 2) The coupled 4-way valve was positioned to transfer the solutions contained in spiral tube-I to the column. The sample solution was then forced to the column followed by the first eluent with nitrogen-gas pressure by manipulating the 3-way valve. During this step, the second eluent was drawn into spiral tube-II.
- 3) Step 2 was repeated as needed, interchanging the two spiral tubes, for successive elution.
- 4) The eluted drops were deposited directly at the centre of a heated tantalum disk (ϕ 24 mm \times 0.05 mm thick) and were evaporated quickly and carefully by controlling the hot plate temperature.

The flow rate was adjusted by controlling the nitrogen gas pressure (0.1–4 MPa) fed to the system. The column was thermostatically maintained at $90 \pm 1^\circ\text{C}$. Detailed operating procedures are included in Appendix A.3.

According to the operating procedures, rapid ion-exchange separation of several actinide elements (Pa, U, Np and Pu), gross separation of the transplutonium elements (Am and Cm) with mineral acid solutions and separation of short-lived transplutonium nuclides (^{250}Fm and ^{246}Cf) were successfully performed. Details are given in Appendix B. It took about 20 min for each separation and the counting source preparation.

2.1.3 Characteristics of the apparatus

The solution in the apparatus contacts only with fluoroplastic material (Teflon and Diflon) and the ion-exchange resin. The apparatus is therefore applicable for many solvents, unless the solvent reacts with fluoroplastic material, and has a reasonably long life at temperatures to 120°C , the decomposition temperature of the cation-exchange resin, and operates at pressures to about 4 MPa, the bursting pressure of the Teflon and Diflon tubes of i.d. 2 mm and o.d. 3 mm. Consequently, it is possible to carry out rapid ion-exchange separation with many kinds of eluents such as hydrochloric, nitric and hydrofluoric acids, organic solvents and mixtures of these at pressures approaching 4 MPa and temperatures approaching 120°C .

The flow of eluents is pulseless. Small amounts of eluent (more than 0.1 ml) can be passed through the column without mixing with another eluent and can be deposited on a tantalum disk.

The system is simple to operate. Only two valves and one tube pump need to be controlled.

2.2 Preparation of ion-exchange columns

In this study, strongly acidic cation-exchange resins and strongly basic anion-exchange resins were used. **Table 2.1** summarizes the characteristics of the resins. The exchange capacity was larger than 1.9 meq/ml for the cation and larger than 1.2 meq/ml for the anion. The CPK08P resin was a macroporous type. The MCI GEL resins were obtained from the Mitsubishi Chemical Industries Limited and the BIORAD resin from the Bio-Rad Laboratories. The resins were washed successively with nitric and/or hydrochloric acid, distilled water and methanol, and then weighed, if necessary, after drying at 90°C before use.

A fluoroplastic tube, Teflon or Diflon, was used to make a resin container. Diflon tubes may be preferred because of their good transparency. The inner diameter of the tube was 1.0, 1.5 or 2 mm and the outer diameter was 3 mm. The dimensions of the columns used are shown in **Table 2.2**.

The ion-exchange column (see **Fig. 2.2** and **Photo. 5**) for the apparatus was prepared by packing the ion-exchange resin into the fluoroplastic tube with pressurized nitrogen gas at about 1 MPa [Usu 87 a, Usu 87b]. The resin was retained with quartz wool at both ends.

The low cost columns were easily prepared. Detailed instructions for column preparation are given in Appendix A.2.

Stainless-steel tubes were more suitable for use with very high pressure but had less resistance to corrosion with some eluting solutions, such as hydrochloric and hydrofluoric acids. Although glass tubes endure various organic solvents and mineral acids except for hydrofluoric acid, the glass tubes used at elevated temperature and pressure gave difficult technical problems. The fluoroplastic tubes adopted for the present apparatus were used with almost all kinds of eluent at temperatures approaching 120°C and pressures to about 4 MPa, even when tubes of i.d. 2 mm and o.d. 3 mm were used. The columns should not be operated beyond 120°C for the cation-exchange resin or higher than 90°C for the anion-exchange resin because of possible decomposition of the resins.

Table 2.1 Ion-exchange resins used in this work.

Name	Type	Particle size	Cross-linking
MCI GEL CK08S	C	11.5±2 μm	8%
CK08Y	C	23.5±4	8
CPK08P	C	35±5	8
CA08S	A	11.0±2	8
CA08B	A	16.0±2	8
CA08Y	A	23.5±4	8
CA06Y	A	23.5±4	6
BIORAD AG 1 X4	A	-400 mesh	4

C: strongly acidic cation-exchange resin,

A: strongly basic anion-exchange resin.

Table 2.2 Dimensions of columns.

Inner diameter	Volume of the resin column				
	0.025 ml	0.050 ml	0.100 ml	0.250 ml	0.500 ml
1.0 mm	31.8 mm	63.7 mm	127.4 mm	—	—
1.5 mm	—	—	56.6 mm	141.5 mm	283.1 mm
2.0 mm	—	—	31.8 mm	79.6 mm	159.2 mm
4.0 mm	—	—	—	—	39.8 mm

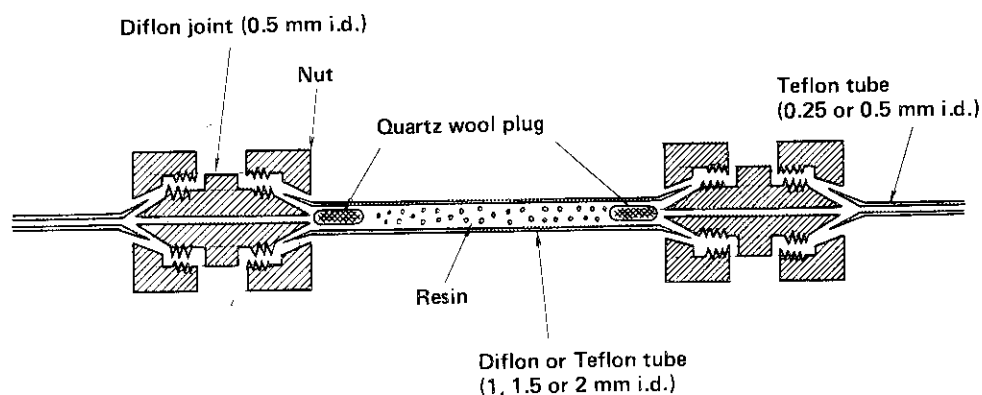
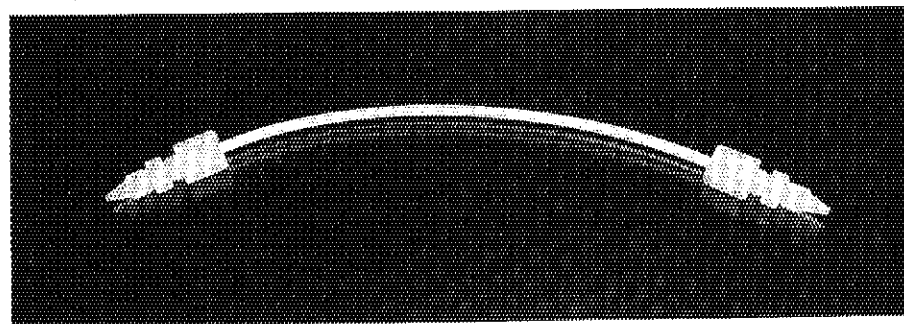
**Fig. 2.2** Diagram of ion-exchange column.**Photo. 5** Prepared ion-exchange column.

2.3 Preparation of mixed eluents of mineral acid and methanol

Nitric acid (sp.gr.: 1.42), fuming nitric acid (sp.gr.: 1.52), hydrochloric acid (sp.gr. 1.18), hydrofluoric acid (46%), hydroiodic acid (sp.gr.: 1.7), methanol (sp.gr.: 0.796), ethanol (sp.gr.: 0.793), acetone (sp.gr.: 0.790–0.793), α -hydroxyisobutyrate (2-hydroxy-2-methyl propionate) with specific reagent grade were used without further purification as eluting agents.

Nitric acid-methanol mixed solutions were prepared by adding a calculated amount of concentrated nitric acid or fuming nitric acid to the required amount of methanol, the volume being precisely adjusted with triple-distilled water.

Hydrochloric acid-methanol mixed solutions were prepared in the same way with concentrated hydrochloric acid and methanol.

Overall concentration of acid in the mixed medium was expressed in M (mole per liter), and content of organic solvent in % (volume percentage to the medium).

2.4 Preparation of tracers

Radioactive tracers of the transplutonium elements used in this study were ^{241}Am , $^{242-244}\text{Cm}$, $^{243,244}\text{Bk}$, $^{246,252}\text{Cf}$ and ^{250}Fm . Other actinide tracers, such as ^{234}Th , ^{233}Pa , $^{235,238}\text{U}$, $^{237,239}\text{Np}$ and $^{238-240}\text{Pu}$ were also used. Fission product tracers were as follows: ^{90}Sr , ^{90}Y , ^{95}Zr , ^{95}Nb , $^{103,106}\text{Ru}$, ^{132}Te , $^{134,137}\text{Cs}$, ^{140}Ba , ^{140}La , $^{141,144}\text{Ce}$, ^{143}Pr , ^{147}Nd , $^{147,149}\text{Pm}$ and $^{154,156}\text{Eu}$.

2.4.1 Short-lived transplutonium tracers synthesized by an accelerator

Isotopes ^{250}Fm ($T_{1/2}$: 30 min) and ^{246}Cf ($T_{1/2}$: 35.7 h) were prepared by the reaction of $^{12}\text{C} + ^{242}\text{Pu}$ or $^{16}\text{O} + ^{238}\text{U}$ using the JAERI tandem accelerator [Shi 84, Shi 85a]. The beam current was about 150 particle nA with 72 MeV for the $^{12}\text{C} + ^{242}\text{Pu}$ system and about 200 particle nA with 88–92 MeV for the $^{16}\text{O} + ^{238}\text{U}$ system. The irradiation durations were 0.5 to 3 h.

Isotopes $^{243,244}\text{Bk}$ ($T_{1/2}$: 4.5 and 4.35 h) were produced by the $^4\text{He} + ^{241}\text{Am}$ reaction [Usu 87f]. The beam current was about 1–2 μA with 28 MeV and the irradiation durations were 2 to 3 h.

These recoil nuclei were caught on an aluminium-catcher foil of 7 μm thickness (ca. 4 mg). Either the catcher foil alone or both the catcher foil and the target were dissolved in 0.1–0.5 ml of aqua regia, and the solution was evaporated to near-dryness. The residue was re-dissolved in concentrated HNO_3 or HCl solution. Then, CH_3OH or $\text{C}_2\text{H}_5\text{OH}$ was added to prepare the sample solution for column loading.

2.4.2 Long-lived transplutonium and other tracers prepared by a reactor

The tracers of ^{241}Am , $^{242-244}\text{Cm}$ and the long-lived fission products were prepared from spent nuclear fuels after elimination of U and Pu by anion-exchange separation with hydrochloric acid solutions [Nat 72]. Relatively short-lived fission product tracers and ^{239}Np were produced by irradiation of UO_2 for 100 min in Japan Research Reactor-4. Tracers ^{237}Np and ^{252}Cf were supplied by the Japan Radioisotope Association. Isotopes ^{234}Th and ^{233}Pa are the daughters of ^{238}U and ^{237}Np , respectively.

In order to investigate basic adsorption behaviour, typical sample solutions containing U, ^{241}Am , ^{244}Cm , ^{252}Cf and several long-lived fission products were prepared with the same composition as that of the first eluent used, or with another chemical composition which caused stronger adsorption of the elements in question. The content of U as target material was, in general, of the order of 1 mg. About 5 mg of Al as catcher-foil material was also added when required.

2.5 Radioactivity measurements

Alpha-ray spectra were measured with silicon-surface-barrier detectors with a multichannel-pulse-height analyzer. The energy resolution with an ^{242}Pu reference source prepared by electrodeposition [Oka 86] was 17.6 keV full width at half maximum peak height (FWHM) at 4.901 MeV. The counting disks, on which several drops of effluent were dried and mounted, were set at about 5-mm distance from the silicon detector in an α -ray spectrometry vacuum chamber. Counting efficiencies determined by measurement of LMRI (Laboratoire de Métrologie des Rayonnements Ionisants, France) standard sources were typically 10–20% with this arrangement.

Gross α and β countings were performed with a silicon-surface-barrier detector and/or 2 π -geometry-gas-flow-proportional counter using PR gas.

Gamma- and X-ray spectra were measured with a coaxial detector and a low energy-photon spectrometer of high-purity germanium to identify γ -emitting nuclides.

2.6 Definition of distribution coefficient, separation factor, number of theoretical plates and resolution

The equilibrium distribution of a specific element between the stationary and moving phases, i.e. ion-exchange resin and eluent, is given by *the distribution coefficient*, K_d . In this study, the K_d value could not be obtained by a batch method because the eluent containing methanol (boiling point of 64.5°C) does not exist in the liquid state at 90°C at 1 atmosphere. The value could therefore be determined only by the column method. The columns used for K_d determination had very small volume and were packed with 10–140 mg resins. The K_d value was calculated by using the formula:

$$K_d = V/M \quad (1)$$

where V is the volume of effluent in ml that passed through the ion-exchange column from the injection of the sample to the peak of elution curve of the element in question and M is the mass of resin, in grams, packed in the column.

The separation factor, α , is the quantity utilized in comparing the elution position of two counter ions 1 and 2. It is defined by:

$$\alpha = K_{d2}/K_{d1} \quad (2)$$

The relative separation factor, S , was also defined to express relative elution position of the transplutonium elements to that of curium:

$$S = K_d/K_{dCm} \quad (3)$$

Band width in a chromatogram can be estimated in terms of *the theoretical plate number*, N , of the column and was determined as follows [Glu 55]:

$$N = 8(V/W)^2 \quad (4)$$

where W is the width of elution peak at the $1/e$ maximum concentration of solute. The quantity N is approximately constant for different bands in the chromatogram when operation conditions such as dimension of the column, particle size of the resin, eluent, flow rate and temperature are fixed. Hence N is a useful measure of column efficiency, the relative ability for separation of a given column condition.

The usual goal in ion-exchange chromatography is the adequate separation of a given sample mixture. *The resolution*, R , which represents the degree of separation of two adjacent peaks on an elution chromatogram, was calculated by the following formula [Ham 60]:

$$R_j^2 = (V_2 - V_1)/(W_1 + W_2) \quad (5)$$

where subscripts 1 and 2 refer to the first and second component eluted from the column. Cross contamination of two components in a Gaussian distribution is about 2% if R equals unity. In order to make the contamination 0.1% or less, R must be 1.5 or more.

Errors of the values were around $\pm 10\%$ in the case of K_d values above 10^2 but the errors increased as the K_d values decreased.

3. Anion-Exchange Separation with the Mixed Media of Nitric Acid and Methanol at Elevated Temperature

3.1 Introduction

Although anion-exchange resins, in general, do not strongly adsorb transplutonium and rare-earth elements from nitric acid solutions [Kra 58, Ich 61], appreciable adsorption has been reported from nearly saturated nitrate solutions [Mar 59, Mar 61, Ada 63, Mar 63, Kra 66] and mixed solutions of nitric acid and water-miscible organic solvents. Such solutions can be successfully made chromatographic elutions of the transplutonium and rare-earth elements. However, it is extremely difficult for nitrate solutions to have high flow rates and to prepare salt-free sources for α -activity measurements because of their high viscosity and salt concentration. On the other hand, methanol, the water-miscible organic solvents, is quite suitable for mixing with nitric acid for rapid ion-exchange separation and for immediate preparation of α -counting sources by direct evaporation of effluent. This is because of its low viscosity, low boiling point and low content of impurities.

Anion-exchange behaviour of the rare-earth [Far 62, Edg 63, Kor 63, Rid 64, Wal 71a, Gus 73a, Gus 73b, Gus 73c, Kna 79] and transplutonium elements [Hin 62, Rid 64, Boc 65, Gus 73a, Gus 73b, Gus 73c, Leb 74, Gus 75, Kna 79, Yao 81, Yao 82, Yao 87] in the mixed media of nitric acid and methanol at ambient temperature has been investigated over a long period of time. In the mixed media, Al is hardly adsorbed on anion exchangers [Kor 63, Wal 71a, Gus 73a, Gus 73c, Leb 74, Gus 75] and U(VI) is slightly adsorbed [Kor 61, Ter 61b, Hin 62, Kor 63, Rid 64], while Th [Kor 61, Ter 61b, Kor 63, Rid 64, Wal 71a, Gus 73a] and Pu(IV) [Hin 62, Gus 73a, Gus 73b, Gus 73c, Leb 74, Gus 75] are strongly adsorbed. The transplutonium and rare-earth elements may therefore be mutually separated in the presence of the macro amounts of Al, U, Th and Pu.

When the anion-exchange separation with the mixed aqueous-organic solvents is made with a rapid flow rate at ambient temperature, it results in low resolution and serious tailing due to slow exchange-reaction rate. However, it does provide better separation at higher temperatures.

Discussed in this chapter is the adsorption behaviour of the transplutonium and rare-earth elements on an anion-exchange resin in the mixed media of nitric acid and methanol at elevated temperatures [Usu 87c, Usu 87e, Usu 87f, Usu 87g, Usu 88a]. Also described are rapid and effective separation methods for the transplutonium and rare-earth elements and techniques for immediate source preparation suitable for α -ray spectrometry.

3.2 Effect of temperature on adsorption

Figure 3.1 shows the effect of temperature (30–90°C) on the relative separation factors of Ce, Pm, Eu, U, Am and Cf to Cm with 0.1 M HNO₃-90% CH₃OH eluent at 5–10 cm/min flow rate using a $\phi 1$ mm \times 6 cm long column packed with 24 mg of CA08S resin. The K_d values of Cm were almost constant for the entire temperature range ($K_d=90\pm 10$). The separation factors converged toward unity with increasing temperature, indicating poor separation at high temperature.

The number of theoretical plates determined with the column for elution of Ce, U, Am, Cm and Cf are shown in Fig. 3.2 as a function of the temperature. The number of theoretical plates increased almost linearly with increasing temperature; this meant separation characteristics improved at high temperatures.

This is easily recognized in a plot of the resolutions of Ce/Am, Am/Cm, Cm/Cf and Cf/U against the temperature of the column as shown **Fig. 3.3**.

While the separation characteristics became better at higher temperature, the anion-exchange column should not be operated above 90°C to prevent severe decomposition of the resin. There were no reactions between HNO₃ and CH₃OH at temperatures to 120°C at elevated pressures.

Figures 3.4 and **3.5** show elution curves of U and the transplutonium elements with an anion-exchange-resin column of CA08Y and eluents of 1 M HNO₃-90% CH₃OH and 0.5 M HNO₃-80% CH₃OH with a high flow rate at ambient (**Fig. 3.4**) and elevated temperatures (**Fig. 3.5**), respectively. Californium and Cm were not separated from each other, and the peak width of Am was very broad at room temperature. At elevated temperature, however, three transplutonium elements (Am, Cm and Cf), U and some rare earths were separated more effectively.

It should be noted that the pressurized eluents, including organic solvents, could be used at elevated temperatures, even if the temperature exceeded the boiling point of the organic solvent at atmospheric pressure.

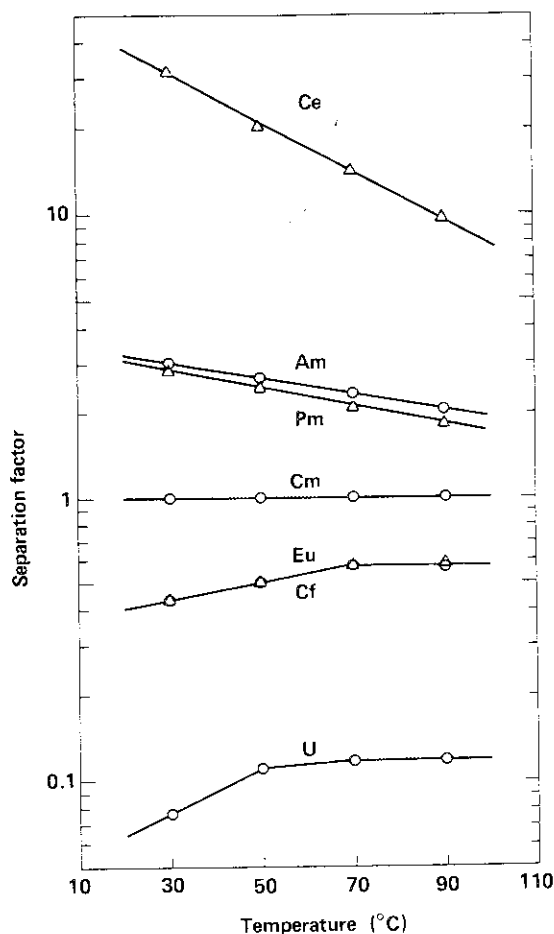

Fig. 3.1 Temperature effect on the separation factors expressed relative to Cm (S_{Cm} : 1, K_{dCm} : 90 ± 10). Column bed: ϕ 1 mm \times 6 cm long, resin: CA08S (23.6 mg), eluent: 0.1 M HNO₃-90% CH₃OH, flow rate: 5-10 cm/min.

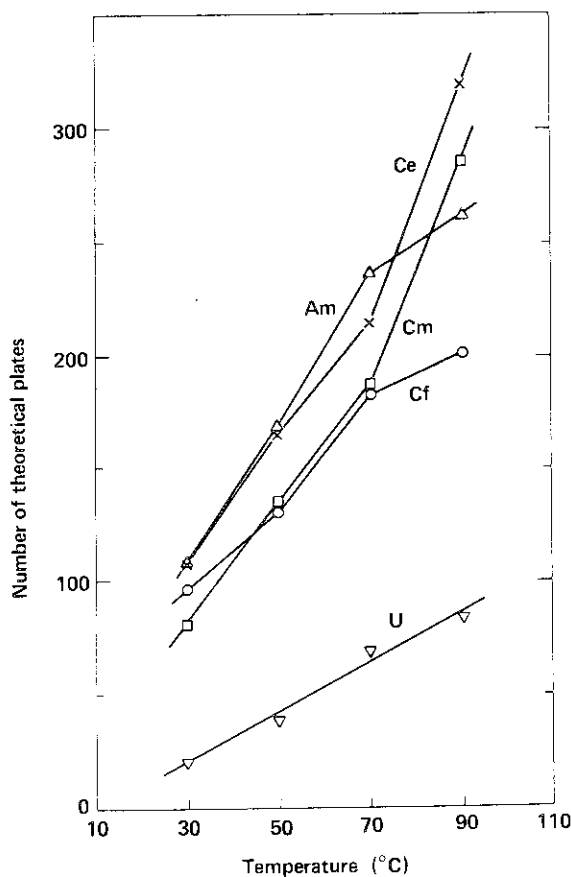

Fig. 3.2 Number of theoretical plates of some elements vs temperature.

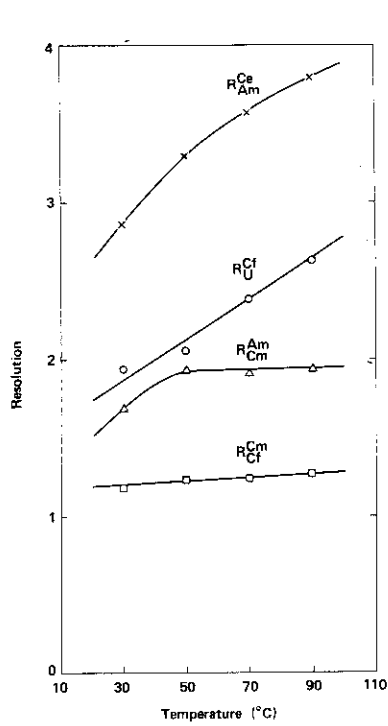

Fig. 3.3 Effect of temperature on the resolution.

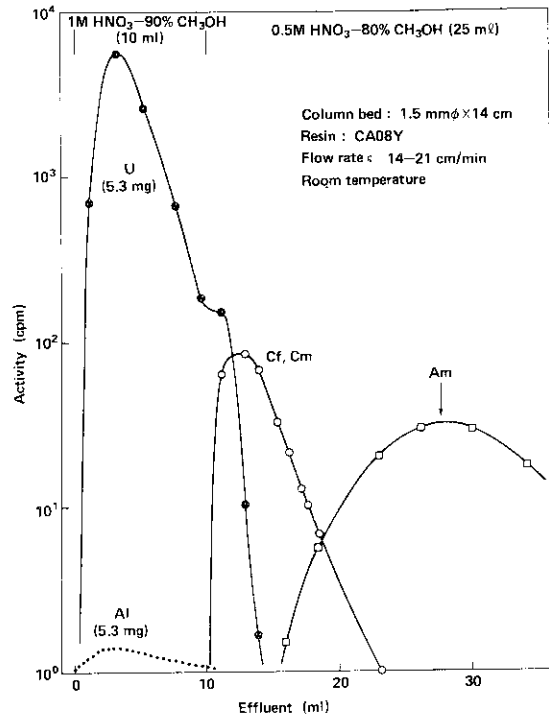

Fig. 3.4 Elution curves for rapid anion-exchange separation of the transplutonium elements from large amounts of U with HNO₃-CH₃OH mixed media at room temperature.

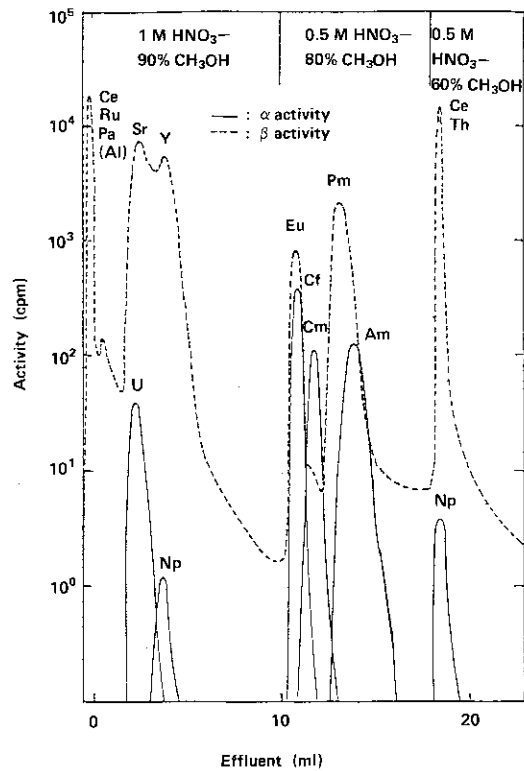

Fig. 3.5 Elution curves for rapid anion-exchange separation of the transplutonium and rare-earth elements from about 2 mg of Al and U with HNO₃-CH₃OH mixed media at 90°C. Column bed: ϕ 1.5 mm \times 14 cm, resin: CA08Y, flow rate: 10-15 cm/min.

3.3 Dependence of the distribution coefficient and the relative separation factor on nitric acid concentration

Since the adsorption behaviour of the transplutonium and rare-earth elements at elevated temperatures was significantly different from the behaviour at ambient temperature, the distribution coefficient and the relative separation factor of the elements at 90°C were determined at various concentrations of the mixed media.

In Fig. 3.6 the distribution coefficients of the transplutonium, rare-earth and some other elements measured in 0.01–2 M nitric acid solutions containing 80, 90 and 95% methanol are plotted. The K_d values increased almost monotonously with increasing concentrations of nitric acid. The only exception was the K_d value of U, which decreased with increasing nitric acid concentration from 0.01 M to 0.1 M in the solution containing 80% CH₃OH. This may be attributable to partial hydrolysis of the nitrate complex of U. The slopes of trivalent elements were 0.5–1, so that the effective ionic charge of these species would be (–0.5)–(–1) in the dilute nitric acid-methanol media. The adsorbed chemical species is conjectured to be $M(\text{NO}_3)_4^-$ [Hai 73].

Figure 3.7 shows the dependence of separation factors on nitric acid concentration. The relative separation factors of Am, Pm and Ce to Cm were almost constant. On the other hand, the relative separation factors of Eu and Cf decreased slightly, and those of Y, Sr and U decreased considerably with increasing concentration of nitric acid. The maximum separation factor between Cf and Cm was given at 1 M acid concentration in 95% methanol solution. Isolation of trans-californium elements with this solution therefore seems most promising.

The trace amounts of Cs and Ru, the macro amount of Al, which was always present as a catcher foil from a target assembly bombarded with a heavy-ion accelerator, and Fe, which is often introduced as reagent contamination, were not adsorbed with any eluents examined.

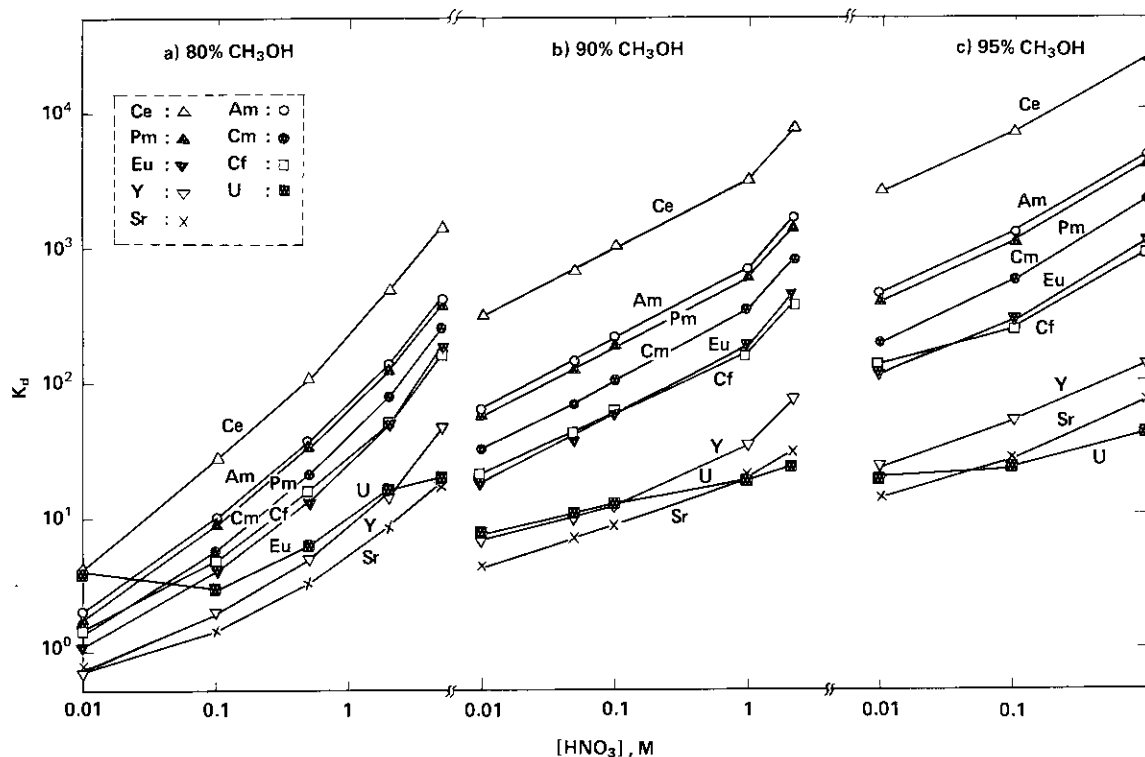

Fig. 3.6 Dependence of the distribution coefficients on acidity at constant alcohol content.

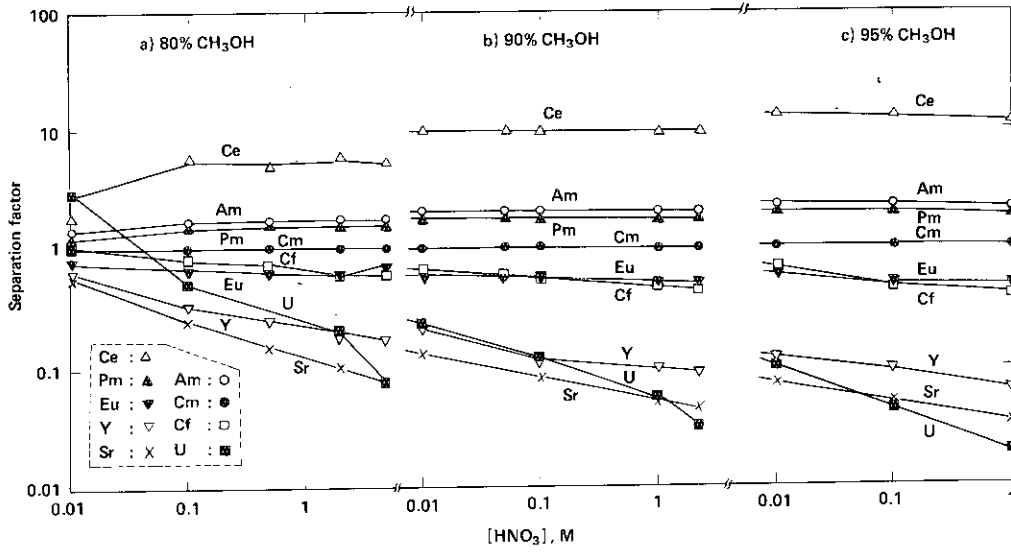

Fig. 3.7 Dependence of the separation factors expressed relative to Cm on acidity at constant alcohol content.

3.4 Dependence of the distribution coefficient and the relative separation factor on methanol content

Dependence of the distribution coefficients on the contents of methanol at 0.01 M, 0.1 M and 1 M concentrations of nitric acid is shown in Fig. 3.8 and that of the separation factors relative to Cm in Fig. 3.9.

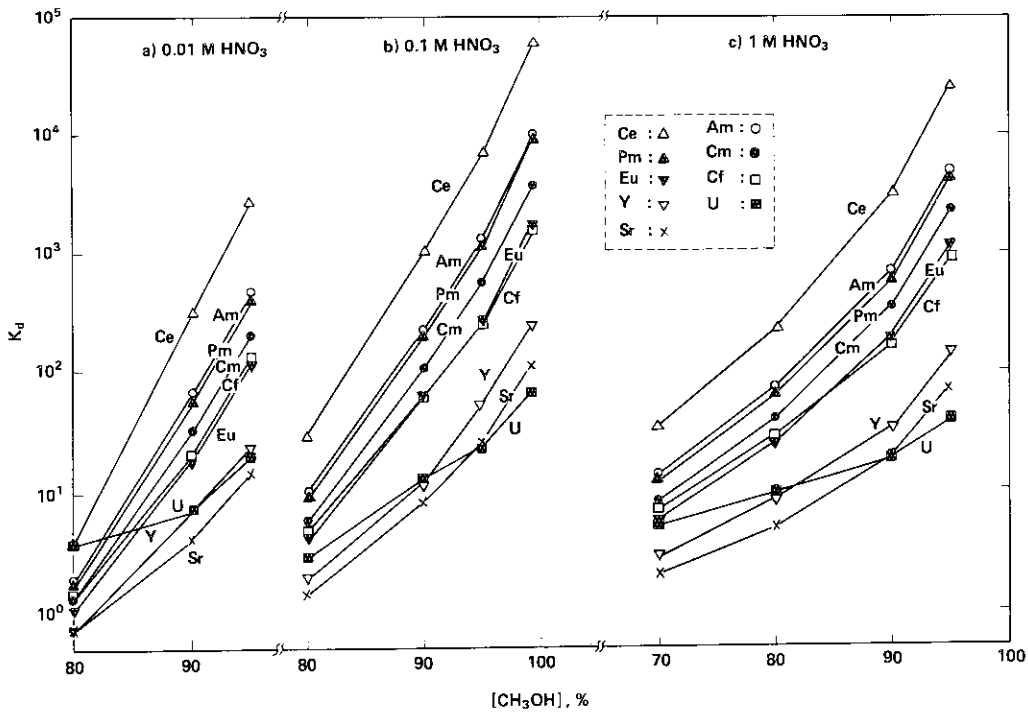

Fig. 3.8 Influence of methanol content on the distribution coefficients at constant acidity.

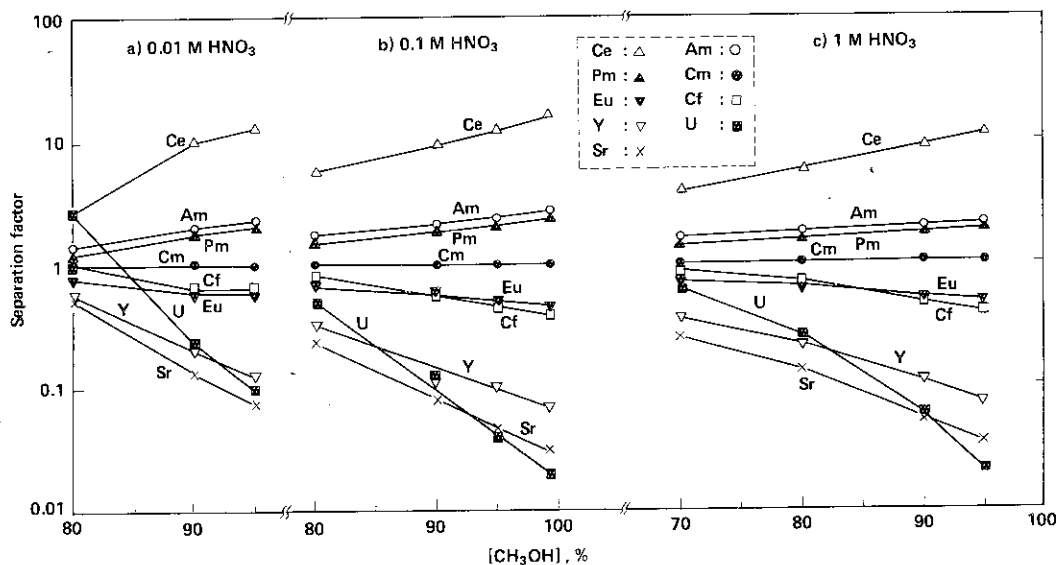

Fig. 3.9 Effect of methanol content on the separation factors expressed relative to Cm at constant acidity.

The K_d values rose sharply as the content of methanol increased and the values of separation factors gradually diverged from unity. The separation factors of Y, Sr and U diverged greatly from unity at high percentages of methanol. Effective separation of the trans-californium elements from Cf and U might be possible with such media.

Figures 3.10 and 3.11 summarize the distribution coefficients. The distribution coefficients for the actinide elements are shown in Fig. 3.10 and those for the rare-earth elements in Fig. 3.11. These are shown as a function of the concentration of HNO_3 and the percentage of CH_3OH .

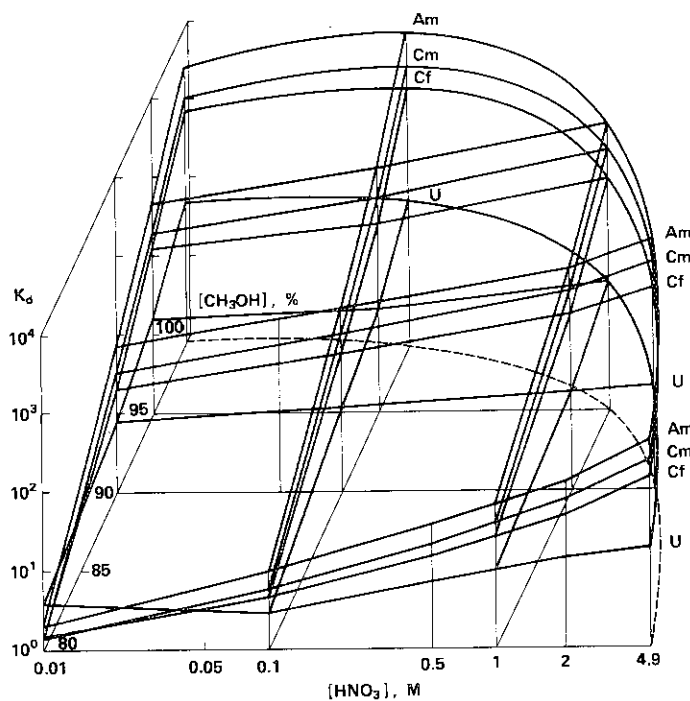

Fig. 3.10 Distribution coefficients of U, Am, Cm and Cf on the anion-exchange resin in HNO_3 - CH_3OH media at 90°C .

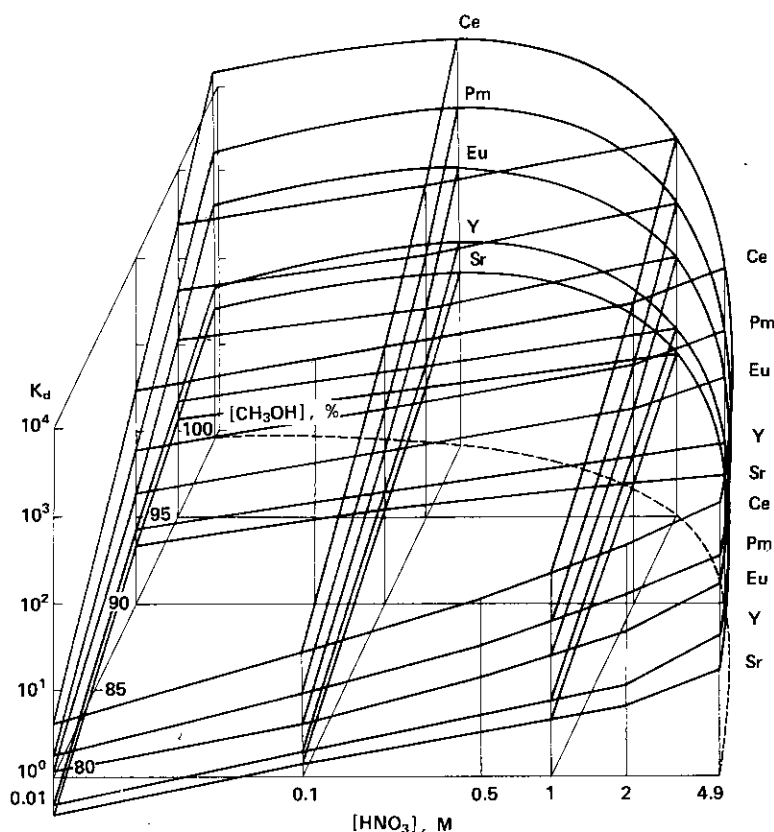

Fig. 3.11 Distribution coefficients of Sr, Y, Eu, Pm and Ce on the anion-exchange resin in HNO_3 - CH_3OH media at 90°C .

3.5 Adsorption behaviour in mixed media of other organic solvents

Korkisch and his co-workers studied the anion-exchange characteristics of various elements using Dowex 1 X 8 resin in several organic solvents at ambient temperature [Kor 63, Wal 71a, Wal 71b, Wal 71c, Wal 71d]. Stewart et al. also surveyed organic solvents [Ste 65]. **Table 3.1** lists the K_d values and the separation factors reported in the literature for Am, Cm and some rare-earth elements in selected solvent systems. Although the K_d values of Am and Cm in a methanol mixture are the smallest among the organic solvents in the table, the separation factor is large. A mixture containing ethanol or propanol is suitable as a sample solution to be charged to a column, since evaporation rates of the mixtures are rather low and the K_d values of the mixtures are expected to be larger at elevated temperatures.

Acetone is also suitable for the rapid separation and source preparation of the transplutonium elements because of its physical properties; low boiling point and viscosity (see **Table 1.2**). The present author examined an acetone mixture as eluent at an elevated temperature. **Figures 3.12** and **3.13** show the anion-exchange chromatograms of some transplutonium and rare-earth elements with 0.5 M HNO_3 -80% acetone and 0.5 M HNO_3 -80% CH_3OH eluents at 90°C , respectively. The K_d values of the actinide and rare-earth elements in the acetone system were compared with that of the methanol system at 90°C as shown in **Fig. 3.14**. Both solutions gave, in general, similar trends and magnitudes of the K_d values but the difference in separation factors between U and the transplutonium elements was larger in the acetone mixture than in the methanol mixture. However, the separation factors for the rare-earth elements in the acetone mixture were rather small compared with methanol system.

When the acetone mixture was standing for a few weeks at ambient temperature, the colour of the solution changed from colourless to slightly yellow. For short periods of time, acetone reacted im-

perceptibly with nitric acid, even at 90°C. Consequently, the acetone mixtures were also used as an eluent at elevated temperatures.

Table 3.1 Separation data for selected solvent-aqueous systems (10% 5 M HNO₃-90% solvent) at ambient temperature [Ste 65].

Solvent	K _d Values					Separation factors (α)			
	²⁴¹ Am	²⁴⁴ Cm	¹⁴⁷ Pm	¹⁶⁰ Tb	¹⁷⁰ Tm	Am/Cm	Pm/Cm	Tb/Cm	Am/Pm
Ethanol	6065	2176	5165	170	258	2.79	2.38	0.13	1.17
2-Propanol	5363	1884	5401	225	479	2.84	2.87	0.12	0.99
1-Propanol	2442	1075	2137	140	215	2.27	1.99	0.14	1.13
3-Methoxy-1-butanol	1455	373	1753	96	45	3.90	4.70	0.26	0.83
Trifluoroethanol	1417	635	1249	65	90	2.23	1.97	0.10	1.13
C-3 Fluoroalcohol	1562	589	1191	—	—	2.66	2.02	—	1.31
Hexylene glycol (diolane)	1046	597	1818	118	214	1.75	3.04	0.91	0.58
Cellosolve	765	308	821	37	31	2.48	2.66	0.12	0.93
Carbitol acetate	1790	1077	4548	222	96	1.67	4.13	0.21	0.40
Glacial acetic acid	1716	840	1518	120	147	2.05	1.18	0.14	1.13
Propionic acid	2241	991	1734	179	403	2.26	1.75	0.18	1.29
Tetrahydrofurfuryl acetate	3174	1690	1200	151	48	1.88	0.71	0.09	2.64
Methanol	535	—	—	—	—	3.25*	—	—	—
Acetone	786	—	—	—	—	—	—	—	—

*: 10% 1 M HNO₃-90% CH₃OH

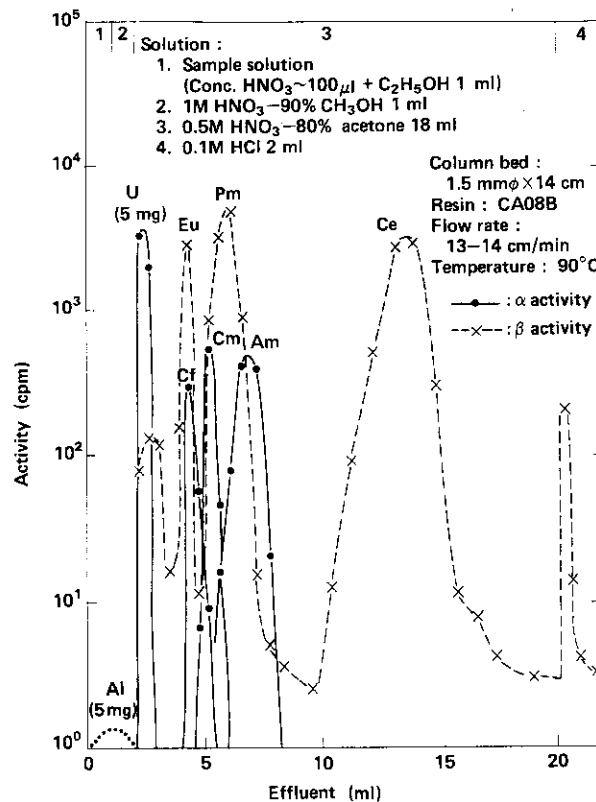

Fig. 3.12 Anion-exchange chromatogram of the transplutonium and rare-earth elements from about 5 mg of Al and U with nitric acid-acetone mixed media at 90°C.

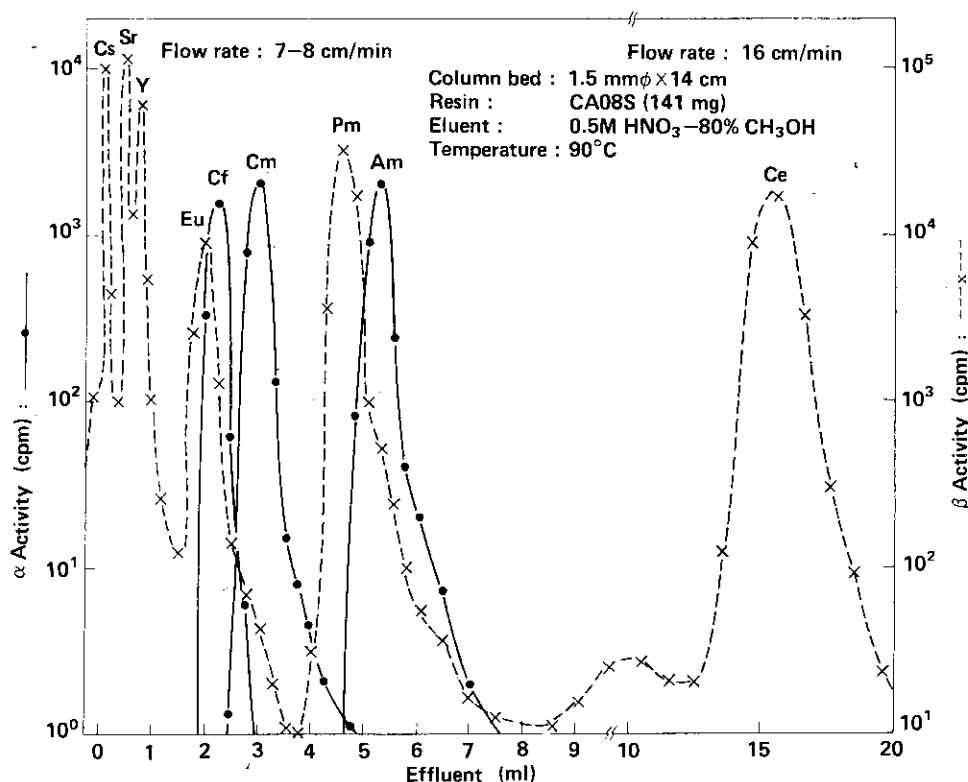

Fig. 3.13 Anion-exchange chromatogram of the transplutonium and rare-earth elements with nitric acid-methanol mixed media at 90°C.

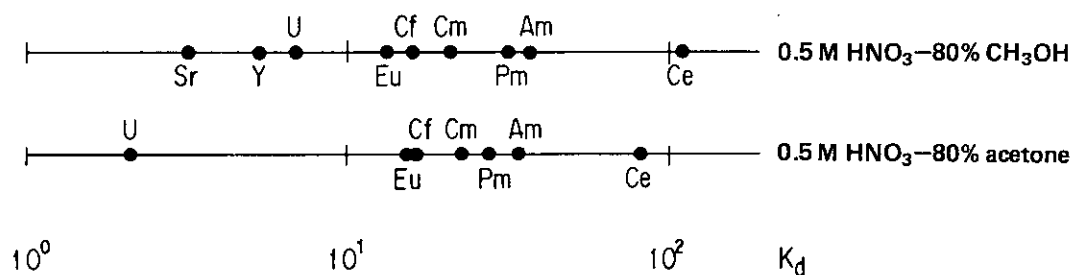

Fig. 3.14 Comparison of the anion-exchange distribution coefficients in methanol and acetone.

3.6 Alpha-source preparation

Sources for the α -ray spectrum measurement were prepared by direct drop-deposition of alcoholic effluents on tantalum metal disks. By the use of these effluents, the sources were free from the macro amount of Al of a catcher foil, U of a target material and Fe from ambient substance as contamination. In addition, the alcoholic media were essentially saltfree. The effluents from the ion-exchange column uniformly deposited and formed a circular deposit of several mm in diameter on a tantalum disk. This was different from the case of aqueous solutions where the effluents evaporated at the periphery of the depositions and formed nonuniform ring-like deposits with most of material at the circumference of a circular deposit.

Figure 3.15 shows typical α -ray spectra obtained from separated samples of Cf, Cm and Am and the spectrum of a ^{242}Pu reference source. The transplutonium elements were eluted with 0.5 M HNO_3 -80% CH_3OH medium from a column ($\phi 1.5 \text{ mm} \times 13 \text{ cm}$ long) of 140 mg of resin (see Fig. 3.13). The values

of FWHM obtained from the Cf, Cm and Am samples were 17.9, 18.3 and 18.8 keV, respectively. The FWHM values were comparable with that of the ^{242}Pu -reference sample prepared by electrodeposition [Oka 86].

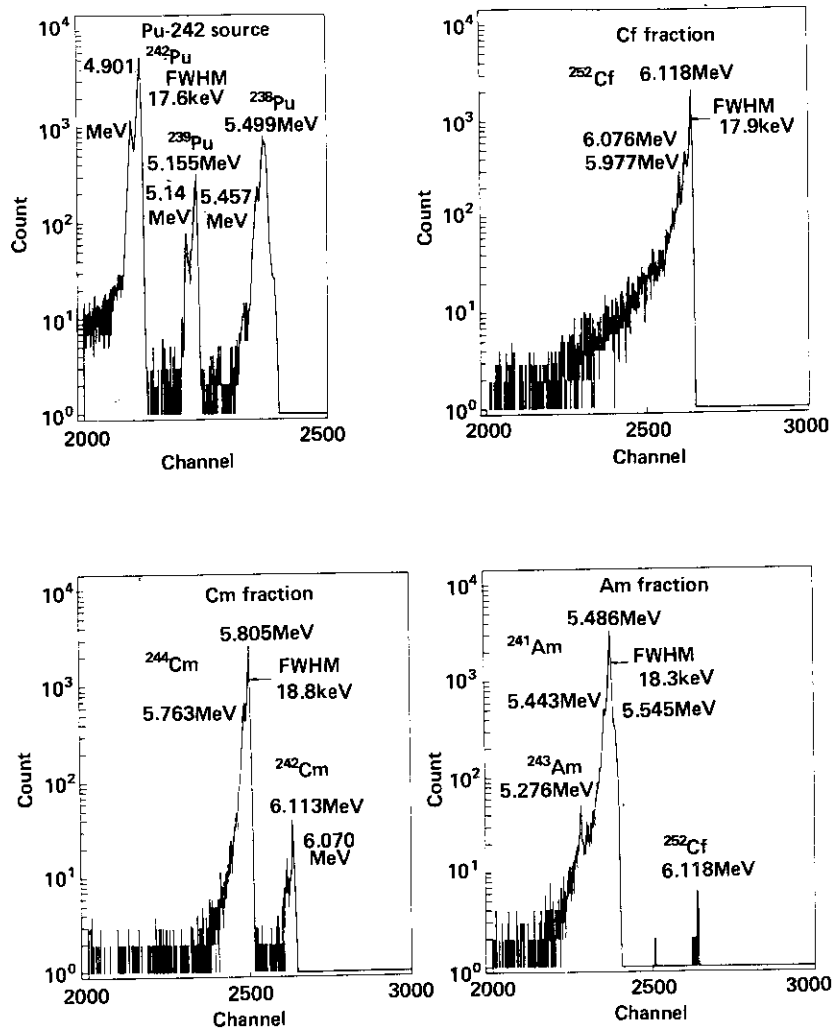

Fig. 3.15 Typical α -ray spectra of the Cf, Cm and Am fractions.

3.7 Separation procedures

3.7.1 Rapid separation of Am, Cm and Cf

Figure 3.16 shows a typical chromatogram for rapid mutual-separation of the transplutonium elements. Each transplutonium (Am, Cm and Cf) and rare-earth element (Ce, Pm and Eu) was separated well from the others and from Cs, U, Sr and Y with a very small column (ϕ 1 mm \times 20 mm long) in 1 M HNO_3 -95% CH_3OH medium at a flow rate of 10-15 cm/min and at 90°C. The transplutonium elements were eluted in the reverse order of their atomic number, similar to that of the rare earths, due to the formation of anionic nitrate complexes [Far 62, Kor 63, Roe 64, Gre 84].

The number of theoretical plates decreased with increasing flow rate. Figure 3.17 shows a chromatogram at a flow rate of 65-70 cm/min, where Cf was isolated in 20 min, but the elution peaks became broad with some overlapping. Other conditions were the same as those given in Fig. 3.16. The number of theoretical plates and the resolutions obtained from Figs. 3.16 and 3.17 are compared in Table 3.2.

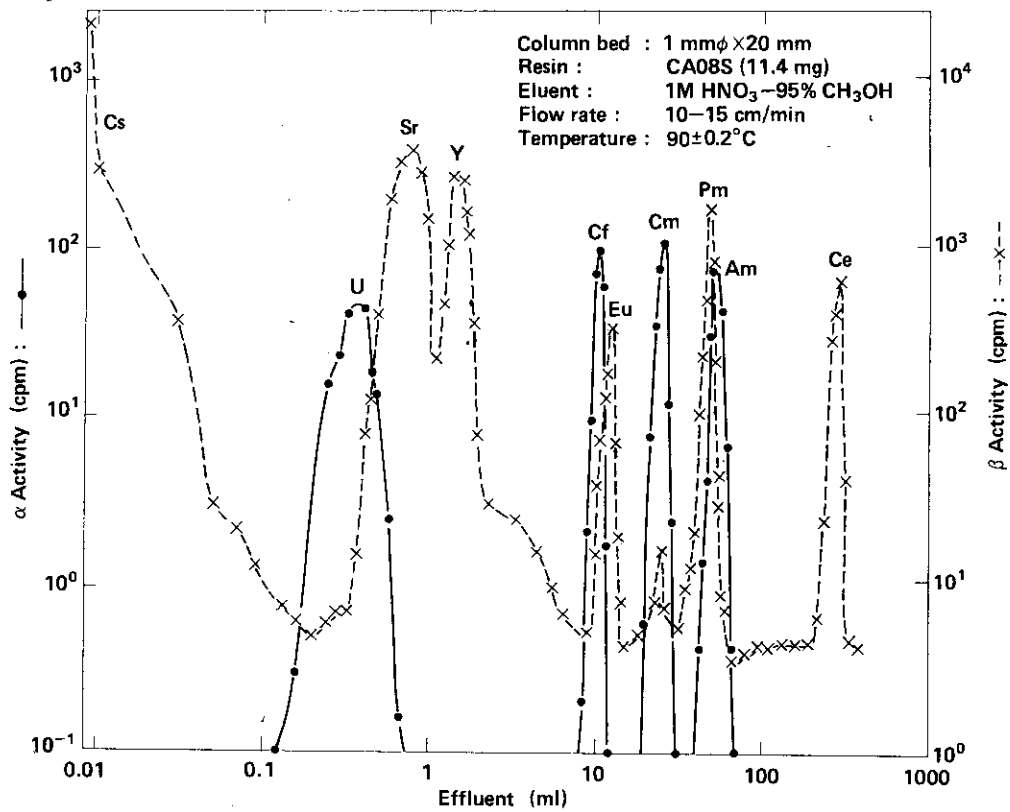

Fig. 3.16 Typical chromatogram of the transplutonium and some other elements.

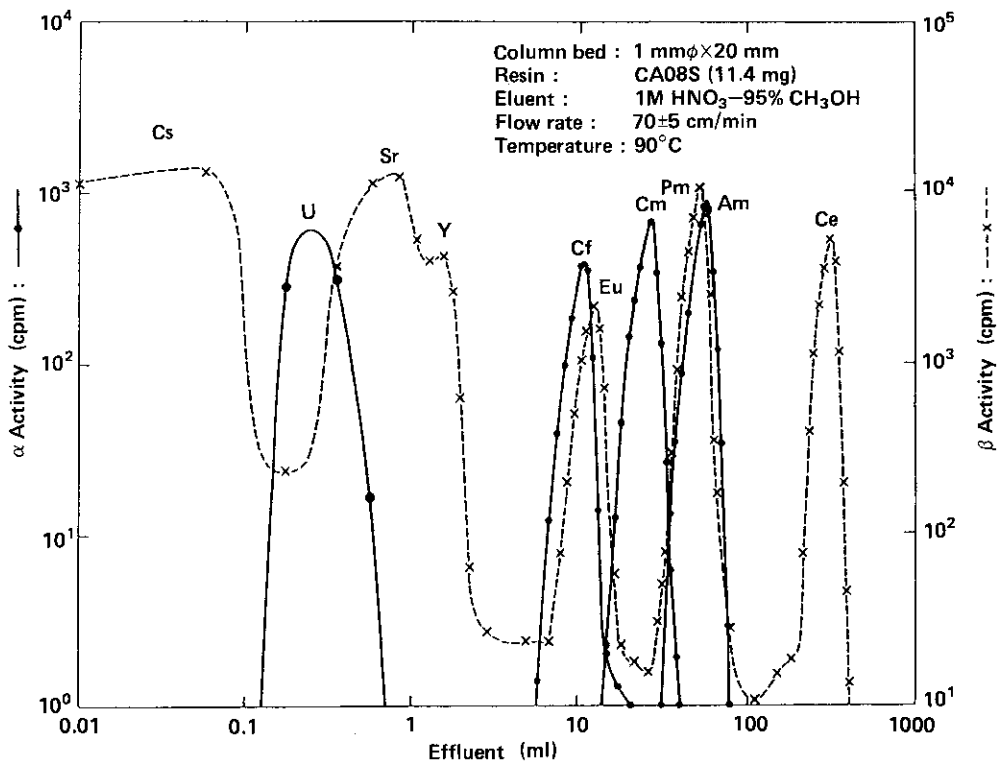

Fig. 3.17 Chromatogram of the transplutonium and some other elements at higher flow rate.

Table 3.2 Comparison of number of theoretical plates (N) and resolutions (R) with different flow rates.

Flow rate (cm/min)	N				R	
	Cf	Cm	Am	U/Cf	Cf/Cm	Cm/Am
10-15	410	770	340	6.0	3.7	2.6
65-70	85	104	105	3.2	1.5	1.4

Figure 3.18 shows the elution curves of several actinide and rare-earth elements separated by acidity-step gradient elutions. The transplutonium elements were effectively separated from macro amounts of Al and U. Such rapid and effective separation was performed by gradient elution both in acid concentration and in alcohol content. The time required for separation of the transplutonium elements and preparation of measurement samples was about 10 min but changed a little with atomic number.

It was possible to separate each element of the transplutonium and rare-earth elements in samples containing Cs, U, Sr and Y at a temperature of 90°C with all eluents examined except 1 M HNO₃-70% CH₃OH and 0.01 M HNO₃-80% CH₃OH. Suitable flow rates were below 5-10 cm/min. Although higher concentrations of nitric acid and higher contents of methanol in the eluent would result in a more effective separation, one should be careful for possible explosion when 3 M or higher concentrated nitric acid is used.

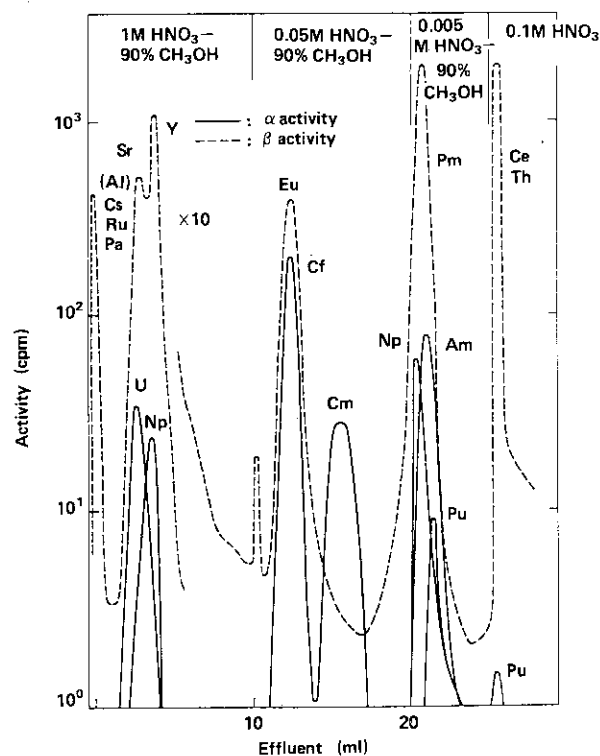

Fig. 3.18 Elution curves for rapid anion-exchange separation of the transplutonium and rare-earth elements from macro amounts of Al and U by the acidity-step gradient method. Column bed: ϕ 1.5 mm \times 14 cm, resin: CA08Y, flow rate: 10-15 cm/min, temperature: 80-90°C.

3.7.2. Rapid separation of ^{246}Cf and ^{250}Fm

As described in Sections 3.3 and 3.4, the separation factor between Cf and Cm increased as the concentrations of HNO_3 and CH_3OH at 90°C increased. For more effective chromatographic separation of heavier transplutonium elements, a mixed medium of 1 M HNO_3 -95% CH_3OH , prepared by mixing high-purity CH_3OH and fuming HNO_3 , was used as an eluent.

Figure 3.19 shows an anion-exchange chromatogram of the separation of ^{250}Fm and ^{246}Cf , synthesized by the $^{12}\text{C} + ^{242}\text{Pu}$ reaction, with the mixed eluent at a flow rate of about 30 cm/min and at 90°C . The column was of 1.0-mm inner diameter and packed with 11.1 mg of CA08S resin. The isotope ^{250}Fm was separated from the other transplutonium elements in about 5 mg of Al foil and the target material (Pu or about 5 mg of U). The distribution coefficients and separation factors of Fm, Cf, Cm and Am are given in **Table 3.3**. The separation factor of Cf/Fm was about 1.3 and was smaller than that of Cm/Cf and Am/Cm. The separation factors between rare-earth elements heavier than Eu were close to unity in the same anion-exchange system [Far 62, Kor 63, Roe 74]. Accordingly, the separation factors of heavy transplutonium elements would be similar to those of the rare-earth elements.

On the basis of the results described above, a set of procedures for rapid mutual-separation of actinide elements using the step-gradient elution technique was proposed. The procedure was applied to the separation of Fm. **Figure 3.20** shows the scheme.

Figure 3.21 displays α -ray spectra of the fractions separated chromatographically. The isotopes ^{250}Fm , $^{244-246}\text{Cf}$ and ^{242}Pu were detected in the respective fractions of Fm+Es, Cf and Pu(IV). Alpha activity was observed only slightly in the Bk, Cm and Am fractions during the initial 2000-s counting, but $^{240,242-244}\text{Cm}$ in the Cm fraction and ^{242}Cm in the Am fraction were detected by a 60000-s counting performed a few days after the separation. The α activity of ^{242}Cm in the Am fraction was attributed to the β -decay product of ^{242}Am ($T_{1/2}$: 16 h). The time required for the separation and the source preparation of Fm was 15 min.

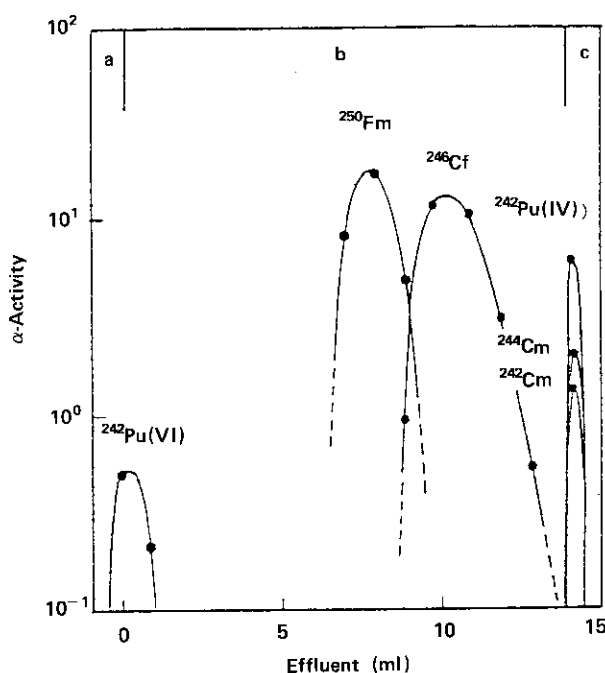
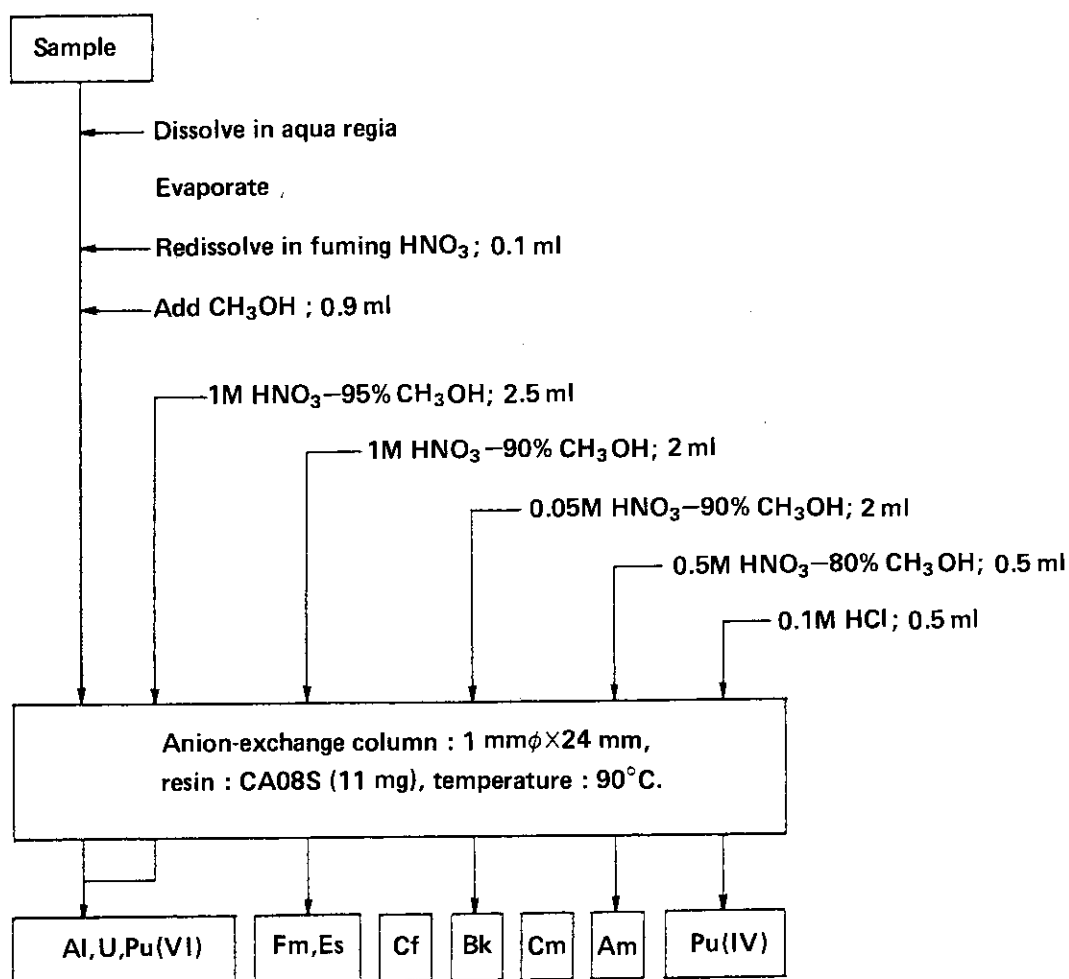

Fig. 3.19 Anion-exchange chromatogram of ^{250}Fm and ^{246}Cf with 1 M HNO_3 -95% CH_3OH mixed medium. a: sample solution (fuming $\text{HNO}_3 + \text{CH}_3\text{OH}$), b: 1 M HNO_3 -95% CH_3OH , c: 0.1 M HCl .

Table 3.3 Distribution coefficients (K_d) and separation factors (α) of the transplutonium elements in HNO_3 - CH_3OH media at 90°C

Eluent		K_d				α		
$[\text{HNO}_3]$	$[\text{CH}_3\text{OH}]$	Am	Cm	Cf	Fm	Am/Cm	Cm/Cf	Cf/Fm
1.0 M	95%	4560	2160	890	680	2.1	2.4	1.3
1.0	90	660	340	160	120	1.9	2.1	1.3
0.1	90	210	104	60	—	2.0	1.7	—
0.05	90	142	68	40	33	2.1	1.7	1.2
0.5	80	37	21	16	—	1.8	1.4	—

**Fig. 3.20** Diagram for rapid mutual-separation of the actinide elements.

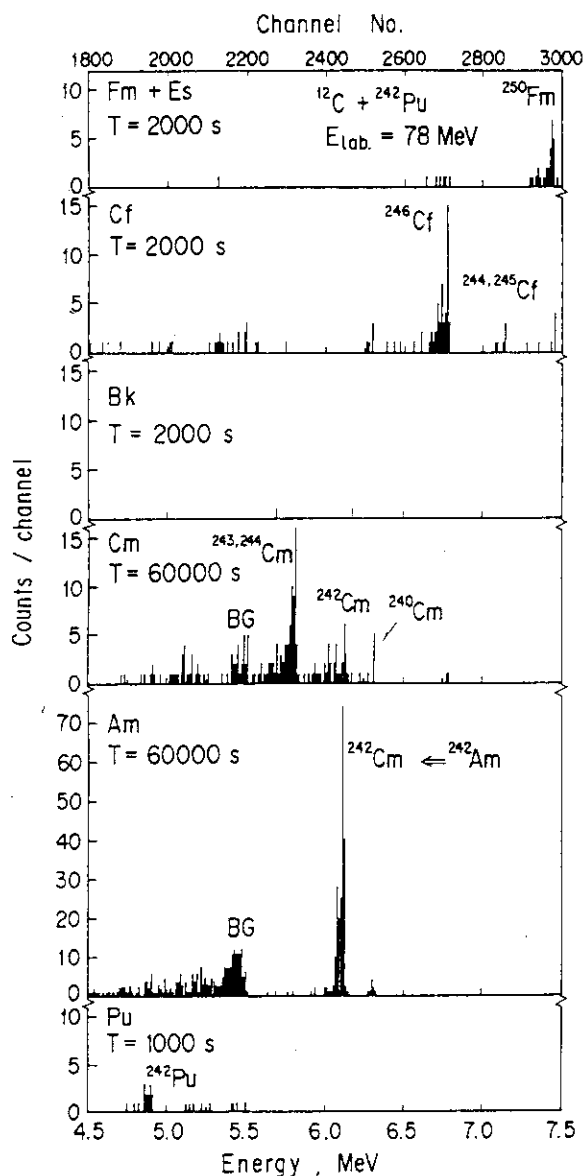

Fig. 3.21 Alpha-ray spectra of each actinide fraction separated by anion exchange with $\text{HNO}_3\text{-CH}_3\text{OH}$ mixed media. T: counting duration.

3.7.3 Rapid mutual-separation of the light lanthanoids

Neutron-rich short-lived nuclides of the lanthanoids, La through Eu, are formed with considerably high yields as fission products of actinide nuclides. From the viewpoint of studying the decay characteristics of those neutron-rich nuclides, establishment of a rapid and effective radiochemical mutual separation method is very important. Since the separation factors among them are relatively large in the anion-exchange chromatography with the $\text{HNO}_3\text{-CH}_3\text{OH}$ eluent, this system is suitable for effective separation of light lanthanoids from each other.

Figure 3.22 shows an anion-exchange chromatogram of an irradiated uranium sample with 0.01 M $\text{HNO}_3\text{-90\% CH}_3\text{OH}$ eluent. After the dissolution of the target material in 0.05 ml of concentrated HNO_3 , the sample solution was mixed with 0.5 ml of $\text{C}_2\text{H}_5\text{OH}$ instead of CH_3OH to increase the distribution coefficients of lanthanoids and to minimize the evaporation rate of the prepared loading solution. The flow rate was about 7 cm/min. The light lanthanoids were effectively and quantitatively separated from each other.

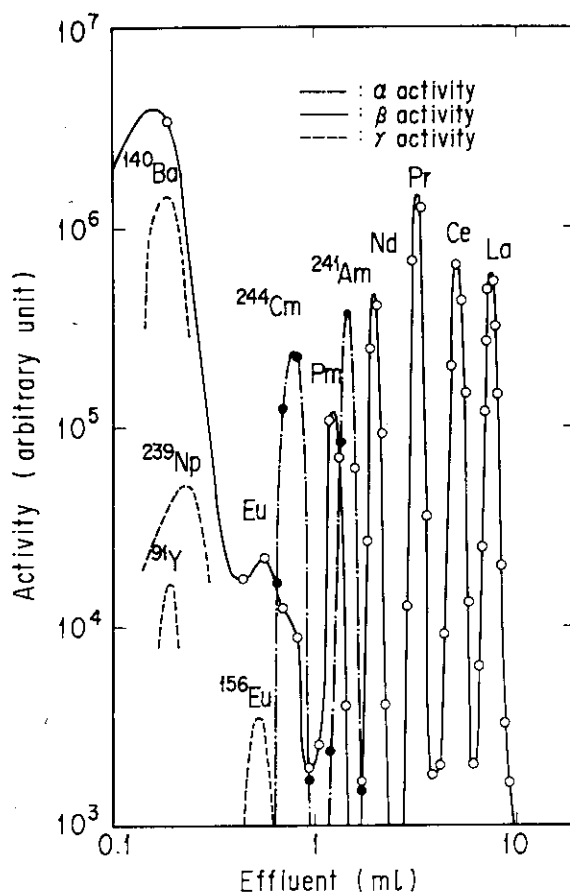

Fig. 3.22 Anion-exchange chromatogram for rapid separation of the light lanthanoids from the irradiated uranium sample with 0.01 M HNO_3 -90% CH_3OH medium at 90°C . Sample solution: conc. HNO_3 (0.05 ml) + $\text{C}_2\text{H}_5\text{OH}$ (0.5 ml), resin: CA08S (23.6 mg), column bed: ϕ 1 mm \times 5.7 cm, flow rate: ca. 7 cm/min.

Chromatograms of the transplutonium elements in the sample were also obtained. The elution position of Sm was superposed upon that of ^{244}Cm . The elution peaks of Y, Eu, Ba and Np existed in front of the ^{244}Cm peak. Cesium, Te and Sr were barely adsorbed on the resin. Hexa-valent U, if present, was eluted at the same position as Y, while tetra-valent Pu was strongly adsorbed on the resin. The latter was eluted with 0.1 M HCl. The light lanthanoids except Pm, the elution position of which overlapped that of ^{241}Am , were therefore separable from the elements mentioned above. The individual lanthanoid fractions were, however, contaminated slightly with the radioactivities of ^{95}Zr and $^{103,106}\text{Ru}$.

An anion-exchange chromatogram for rapid separation of the light lanthanoids with 0.5 M HNO_3 -80% CH_3OH eluent was also obtained, as shown in **Fig. 3.23**. Separation factors of the rare-earth and transplutonium elements relative to Nd with both 0.01 M HNO_3 -90% CH_3OH and 0.5 M HNO_3 -80% CH_3OH eluents are given in **Table 3.4**. These are compared with the cation-exchange chromatogram with α -hydroxyisobutyrate solution [Cho 56a]. Although the separation factors among the lanthanoids heavier than Eu were similar at ambient temperature [Far 62, Kor 63, Roe 74] those for the lighter elements were reasonably large enough even at elevated temperatures. The separation factors were comparable to those observed in cation-exchange chromatography.

The resolutions of mutual separation among the lanthanoid and transplutonium elements obtained with the HNO_3 - CH_3OH eluents are given in **Table 3.5**. The cross contamination of two adjacent elements was 1% or less. The mixed medium of 0.01 M HNO_3 -90% CH_3OH gave superior separation

characteristics to that of 0.5 M HNO₃-80% CH₃OH as eluent.

Although it took 2.5 h to separate all the lanthanoids with the 0.01 M HNO₃-90% CH₃OH eluent, more rapid separation might be done at a higher flow rate with the gradient elution technique. This method would be useful for the rapid separation of Nd and La for burn-up measurements of spent nuclear fuel with isotope-dilution-mass spectrometry of light lanthanoid isotopes, such as ¹³⁹La, ¹⁴⁸Nd and the sum of Nd isotopes [Abe 71, Gre 84, AST 85, Ell 86, Cas 86]. The separation techniques for burn-up measurements are described in Chapter 6.

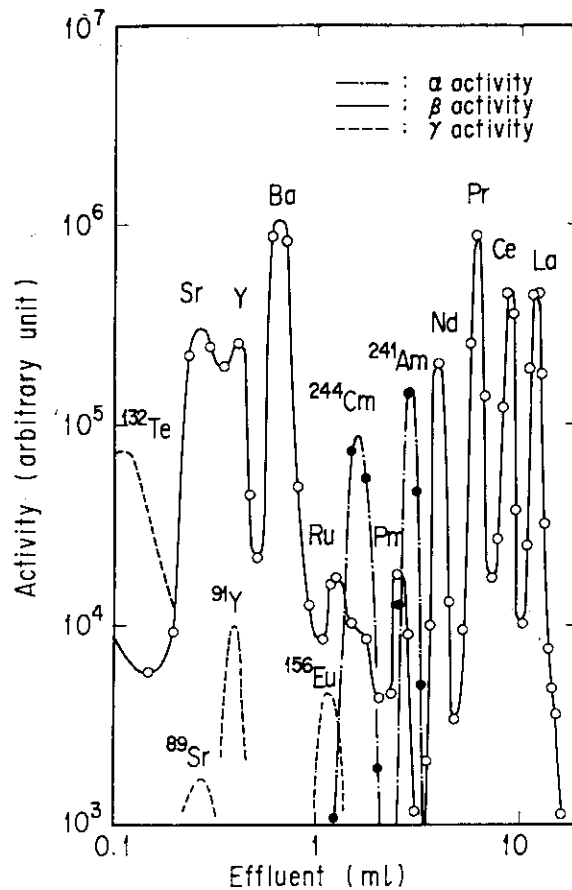

Fig. 3.23 Anion-exchange chromatogram for rapid separation of the light lanthanoids from the irradiated uranium sample with 0.5 M HNO₃-80% CH₃OH medium at 90°C. Sample solution: conc. HNO₃ (0.1 ml) + C₂H₅OH (0.9 ml), resin: CA08B (150 mg), column bed: ϕ 1.5 mm \times 14 cm, flow rate: 3-5 cm/min.

Table 3.4 Separation factors relative to Nd.

Method	Y	Eu	Cm	Pm	Am	Nd	Pr	Ce	La
Anion exchange with 0.01 M HNO ₃ - 90% CH ₃ OH	0.1	0.25	0.38	0.60	0.70	1	1.62	2.55	3.7
Anion exchange with 0.5 M HNO ₃ - 80% CH ₃ OH	0.1	0.28	0.40	0.66	0.71	1	1.56	2.23	3.0
Cation exchange with α -hydroxyisobutyrate	0.04	0.21	0.52	0.62	0.72	1	1.58	2.53	5.17

Table 3.5 Resolutions of mutual separation among the light lanthanoid and transplutonium elements.

Eluent	Cm/Am	Am/Nd	Pm/Nd	Nd/Pr	Pr/Ce	Ce/La
0.01 M HNO ₃ - 90% CH ₃ OH	1.8	1.4	1.9	1.9	1.7	1.4
0.5 M HNO ₃ - 80% CH ₃ OH	1.6	1.2	1.5	1.6	1.5	1.4

3.7.4 Rapid separation of Bk from Ce

The behaviour of Bk(III) with the HNO₃-CH₃OH eluent at ambient temperature has been investigated by Guseva et al. [Gus 71, Gus 73b, Gus 75, Gus 76]. They reported that the half-width of the berkelium elution curve with 0.75 M HNO₃-80% CH₃OH was smaller than that with 0.1 M HNO₃-90% CH₃OH. The latter eluent is expected to be more efficient at elevated temperatures because the separation factor of Cf/Cm increases with the alcohol content and the elution peak of the transplutonium elements sharpens at elevated temperatures. Elution with a higher alcohol content, such as 1 M HNO₃-95% CH₃OH, may be more effective for mutual-separation of those elements

Since both Bk and Ce can readily be oxidized to their tetra-valence state, Bk and Ce are separated from the other transplutonium and rare-earth elements by solvent extraction [Pep 57, Liu 83]. In this case, a separation of Bk from Ce is necessary. **Figure 3.24** shows an elution profile for the rapid separation of Bk and Ce by using 23 mg of CA08S resin and 0.5 M HNO₃-80% CH₃OH eluent. The dotted curves show the elution of Am and Cf when they are present. The separation factor of Bk/Ce was very large, so that Bk was easily separated from Ce. This method is very useful for both the rapid separation and the source preparation, compared to conventional methods [Gus 71, Gus 76, Liu 81].

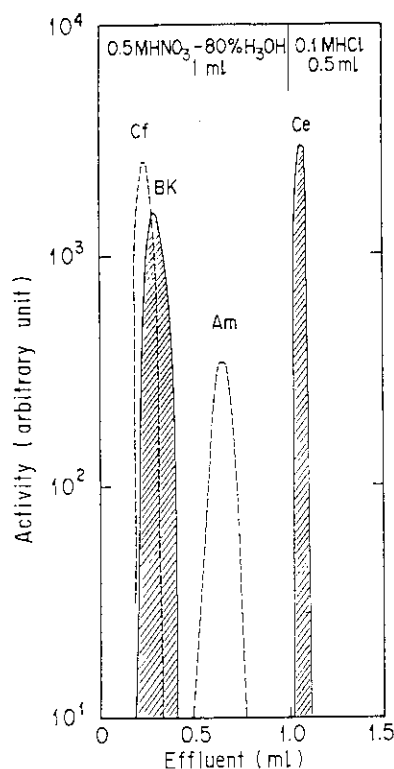

Fig. 3.24 Anion-exchange separation of Bk from Ce with HNO₃-CH₃OH system. Column size: ϕ 1 mm \times 5.7 cm, resin: CA08S (23 mg), sample solution: 1 M HNO₃-95% CH₃OH, flow rate: 13 cm/min.

4. Anion-Exchange Separation with the Mixed Media of Hydrochloric Acid and Methanol at Elevated Temperature

4.1 Introduction

In hydrochloric acid solutions, the transplutonium elements are adsorbed on strongly basic anion-exchange resins only from highly concentrated solutions such as 13 M HCl [Tho 54, War 56, Bun 59, Hei 81]. The solution is prepared by saturating concentrated hydrochloric acid solution with hydrogen-chloride gas. In lithium-chloride solutions of 10 M or higher, the elements are also adsorbed on resins in the form of negatively charged chloro-complexes and can be easily separated from rare-earth elements at 87°C [Hul 61].

The extent of formation of the anionic chloro-complexes of transplutonium elements is enhanced by adding water-miscible organic solvents to the aqueous chloride solutions. Guseva et al. have studied the adsorption of Am and Eu on anion-exchange resins in a broad range of lithium-chloride concentrations (0.6–13.06 M) and separated the elements from each other by anion-exchange chromatography with 8 M LiCl–40% C₂H₅OH solution at room temperature [Gus 70]. Orlandini et al. have investigated the adsorption of tri-valent transplutonium and rare-earth elements from hydrochloric acid-acetone mixtures using Dowex 1 resin [Orl 68]. High Am/Yb separation factors were obtained in mixtures that had a 2 M solution of lithium chloride in which the volume ratio of acetone to hydrochloric acid was 60:40 and 75:25 (separation factors: 21.5 and 28.8, respectively). However, separation experiments conducted under these conditions have not given satisfactory results because of a considerable tailing in the elution of Yb.

Also studied was anion-exchange separation of the transplutonium elements with alcoholic solutions saturated with hydrogen-chloride gas. Morrow performed the separation of Es and Cf from Am and Cm with 20–40% methanol solutions saturated with hydrogen-chloride gas and the separation of actinides from the lanthanides as well [Mor 66]. Aleksandrov et al. have reported the separation of Cf from Cm with 8.5 M HCl–40% C₂H₅OH solution [Ale 77].

Difficulties arise when the systems described above are applied to rapid separation of the transplutonium elements at ambient temperature because of (1) the large flow resistance caused by the high viscosity of the solutions, (2) the low resolutions due to the slow exchange-reaction rates and, (3) in many cases, a large amount of salt remaining in the sample unsuitable for α -ray spectrometry.

A mixture of hydrochloric acid and methanol has a number of advantages as an eluent for the rapid separation and measurement of α -emitting nuclides. Namely, (1) fast flow rates are obtained from the low viscosity of methanol, (2) salt-free effluents which are well suited for source preparation for α counting are formed, (3) the sources can be immediately prepared by simple evaporation of the mixtures, and (4) the eluents can be prepared easily. Except for the transplutonium elements, the anion exchange with the mixed media of hydrochloric acid and organic solvents has been studied for various elements by many investigators [Ber 58, Fri 61, Ter 61a, Wil 61, Kor 62, Kor 64a].

As described in Chapter 3, the separation of transplutonium elements from rare-earth elements could not be achieved in a system of anion-exchange resins and HNO₃–CH₃OH mixed media at elevated temperatures. However, the obvious difference in adsorption behaviour between chloro-complexes of the transplutonium and rare-earth elements requires the further investigation of the chloride system. This chapter deals with adsorption behaviour of the transplutonium elements on anion-exchange resins from

mixtures of hydrochloric acid and methanol at elevated temperatures for rapid separation of the transplutonium elements from rare-earth elements and immediate source preparation for α -ray spectrometry [Usu 87d, Usu 87e, Usu 87f, Usu 88a].

4.2 Adsorption of the transplutonium elements in mixtures of hydrochloric acid and methanol

Appreciable adsorption of Am, Cm and Cf was observed in 0.5 M or more of concentrated hydrochloric acid solutions which contained 85% or more of methanol.

Figure 4.1 shows a typical chromatogram of the transplutonium elements separated with an eluent of 0.5 M HCl-90% CH₃OH at 90°C using a column packed with 0.25 ml of CA08Y resin. The rare earths passed through the column. The elements Cm and Am were subsequently eluted separately from Cf. Uranium was adsorbed strongly at the top of the resin column in a narrow band.

The elution behaviour of the transplutonium elements from the anion-exchange resin with the HCl-CH₃OH mixtures was similar to that with aqueous solutions of concentrated chloride [Tho 54, Hul 61], 8 M LiCl-40% C₂H₅OH mixed solution [Gus 70] and 20-40% alcoholic solutions saturated with hydrogen-chloride gas [Mor 66, Ale 77], indicating the adsorption of the transplutonium elements in the form of anionic chloro-complexes.

Successful separation was accomplished at 90°C, while the separation at room temperature was poor because of broad elution peaks and serious tailing.

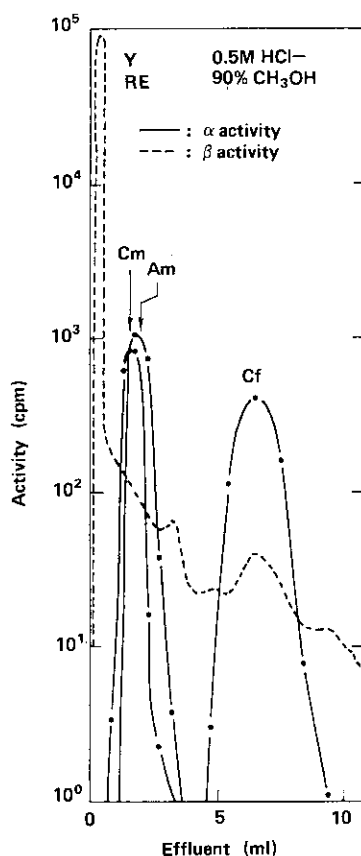

Fig. 4.1 Typical anion-exchange chromatogram of the transplutonium and rare-earth elements with 0.5 M HCl-90% CH₃OH mixed medium at 90°C and about 7.5 cm³/min. Resin: CA08Y, column bed: ϕ 1.5 mm \times 14 cm.

4.3 Effect of hydrochloric acid concentration

The dependence of the distribution coefficients (K_d) of the transplutonium elements on the hydrochloric acid concentration of solutions containing 90% methanol is shown in Fig. 4.2. The K_d values increased almost monotonously as the concentration of hydrochloric acid increased.

The slopes of the curves were 2.3–3.5 instead of 0.5–1 obtained in the mixed media of nitric acid and methanol (see Chapter 3). The difference in the slope can be explained in terms of ionic charge of the adsorbed species. The slope 2.3–3.5 corresponds to $M(\text{Cl})_6^{3-}$ in the mixed media of dilute hydrochloric acid and methanol.

When hydrochloric acid was used, coexisting Cs, Sr, Ru and Al were barely adsorbed on the resin in the solution containing 80% or more of methanol. However, U and Fe were strongly adsorbed.

Figure 4.3 shows the separation factors of Am, Bk, Cf and Fm and the rare-earth elements relative to Cm. In the range of 0.3 M to 1.3 M HCl, the separation factors between Cm and Am and between Am and Cf were constant, 1.22 ± 0.02 and 3.1 ± 0.2 , respectively. Therefore, it is easy to separate Cf from Am and Cm efficiently in this range of hydrochloric acid concentration. On the other hand, since the separation factor between the rare-earth and transplutonium elements increased with increasing acidity, more effective group-separation was obtained by the use of higher concentrations of hydrochloric acid in the eluent. With 1.3 M HCl–90% CH_3OH solution, the separation factor between Cm and the rare-earth elements increased to about 40, as indicated in Fig. 4.3.

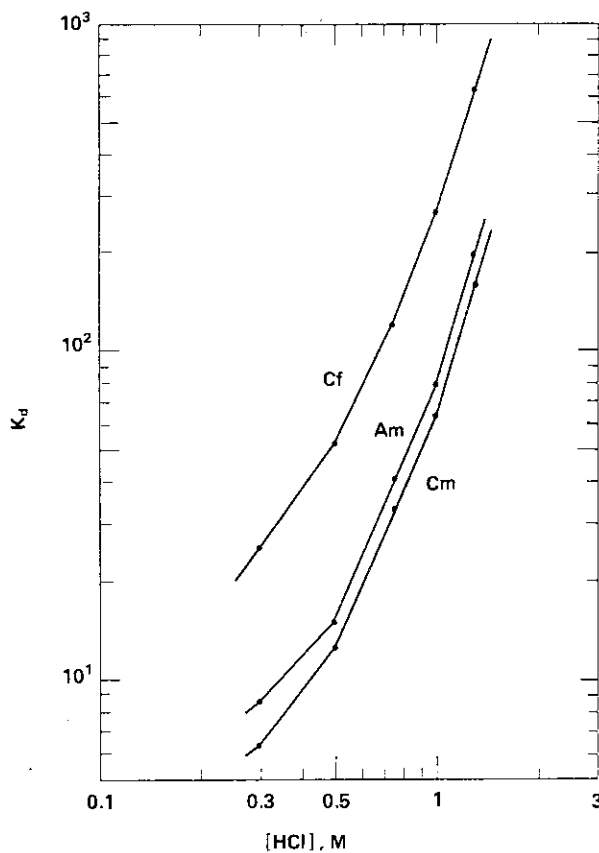

Fig. 4.2 Influence of hydrochloric acid concentration on the anion-exchange distribution coefficients of the transplutonium elements with solutions containing 90% CH_3OH .

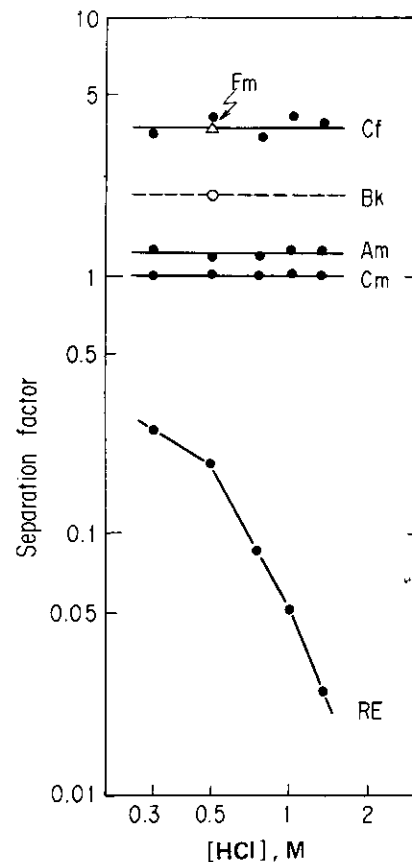

Fig. 4.3 Separation factors of rare earths, Am, Bk, Cf and Fm relative to Cm for anion exchange in hydrochloric acid solutions containing 90% CH_3OH at 90°C.

4.4 Effect of methanol content

The influence of methanol content on the distribution coefficients was also examined at 0.5 M and 1 M concentrations of hydrochloric acid as shown in Fig. 4.4. The transplutonium elements were not adsorbed from 0.5 M hydrochloric acid solutions containing methanol at concentrations of 85% or less, or from 1 M hydrochloric acid solutions containing methanol at concentrations of 80% or less.

The K_d values of the transplutonium elements rose very sharply with increasing concentrations of methanol, while the separation factors among the transplutonium elements were almost unchanged. The rare-earth elements were not appreciably adsorbed.

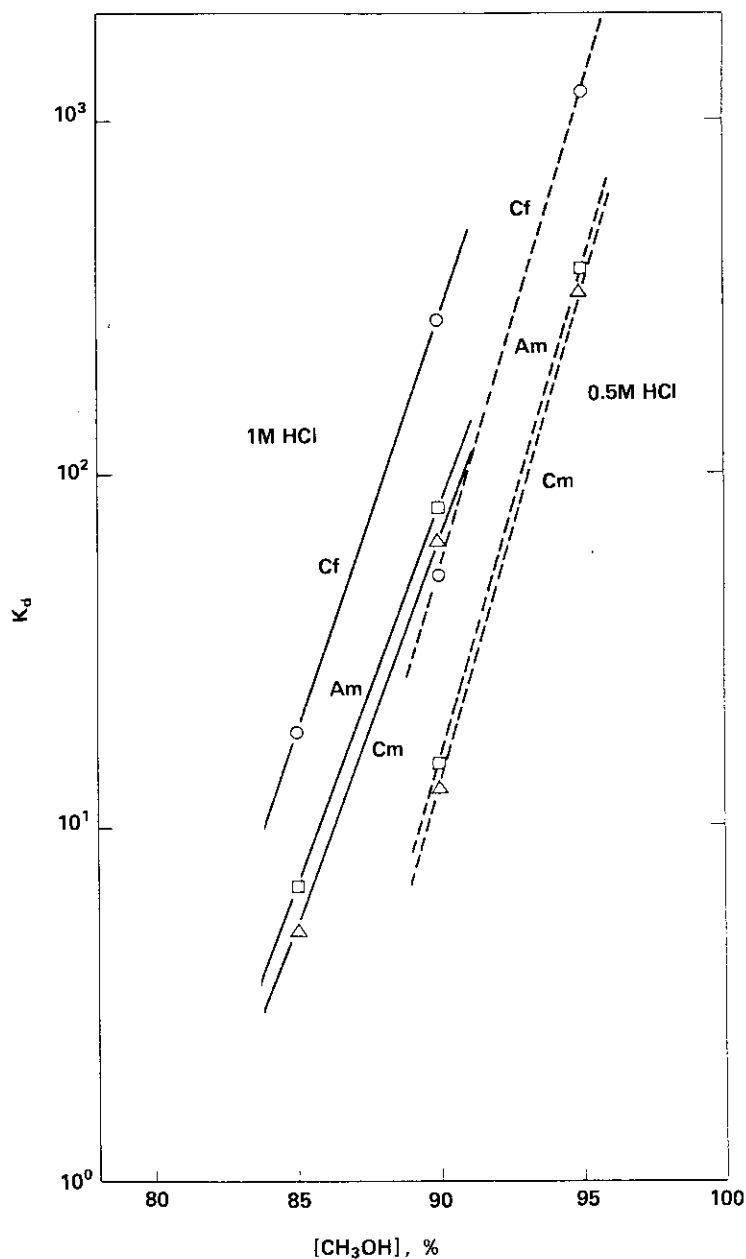

Fig. 4.4 Dependence of the anion-exchange distribution coefficients of the transplutonium elements on the alcohol content in solutions of 0.5 and 1 M HCl.

4.5 Adsorption behaviour in mixed media of other organic solvents

Orlandini and Korkisch have investigated the influence of 20 water-miscible organic solvents on the adsorption of transplutonium and rare-earth elements from hydrochloric acid media at room temperature [Orl 68]. **Table 4.1** shows the distribution coefficients and separation factors for Am(III) and Yb(III) in several organic solvents (75%) mixed with concentrated hydrochloric acid (25%) for Dowex 1 X8 resin. The separation factor for the acetone mixture is the highest. The mixture has a yellow colour when freshly prepared, even at room temperature [Cum 68], and changed to a reddish brown colour after a few days due to a reaction between hydrochloric acid and acetone. When the mixture was used as an eluent at 90°C and the effluent was evaporated on a tantalum-counting disk, a large amount of the reaction products of hydrochloric acid and acetone were often formed. Therefore, the acetone mixture is not appropriate for the use.

Table 4.1 Distribution coefficients (K_d) and separation factors (α) for Am(III) and Yb(III) in various organic solvents (75%) mixed with concentrated hydrochloric acid (25%) on Dowex 1 X8 resin at ambient temperature [Orl 68].

Solvent	K_d Values		Separation factors (α)
	Am(III)	Yb(III)	Am/Yb
Acetone	17.6	3.7	4.8
Acetic acid	1.5	0.39	3.8
Methyl ethyl ketone	16.7	5.7	2.9
1,2-Bis (2-methoxy-ethoxy) ethane	3.9	1.4	2.7
Tetrahydrofuran	5.2	2.1	2.5
Monoethylether of ethylene glycol	2.2	0.9	2.4
Methanol	1.1	0.48	2.3
Monomethylether of ethylene glycol	0.45	0.21	2.1
Pyridine	0.75	0.4	1.8
Ethanol	8.4	5.1	1.6
2-methyl-1-propanol	15.3	10	1.5
2-propanol	20.3	14	1.4
Monobuthylether of ethylene glycol	2.8	1.9	1.4
Hexone	10	7.6	1.3
1-Butanol	12	10	1.2
Cyclohexanol	16.6	13	1.2
Ethylene glycol	< 0.1	< 0.1	—
Propylene glycol	ca. 0.1	< 0.1	—
Glycerol	< 0.1	< 0.1	—
Dimethylformamide	< 0.1	< 0.1	—

Because of the poor performance of other organic solvents, the author has studied the adsorption behaviour of transplutonium elements only in alcohol media. The K_d values of the transplutonium and rare-earth elements in 0.5 M HCl-90% C₂H₅OH mixture were determined at 90°C using the same column and elution conditions as those adopted for the studies on methanol. **Figure 4.5** compares the K_d values in methanol and ethanol. The K_d values in the ethanol system were 6-8 times larger than those in the

methanol system. The relative elution positions of the transplutonium and rare-earth elements were similar to that in the methanol system, although the separation factors decreased.

It has been reported that the K_d values of U and Th in aliphatic alcohols containing hydrochloric acid increase with a decrease of the dielectric constant of the solvent [Ter 61b, Kor 62, Kor 64b]. Therefore, long-chain alcohols, such as 1-propanol and 1-butanol, might result in stronger adsorption of transplutonium elements on the resin than methanol.

However, such alcohols are unsuitable for rapid group-separation because of their high viscosity (see **Table 1.3**), excessively large K_d values and the relatively small separation factors between the transplutonium and rare-earth elements. Mixtures with ethanol and hydrochloric acid are suitable as sample solutions for column loading because of their high adsorbabilities and low evaporation rates.

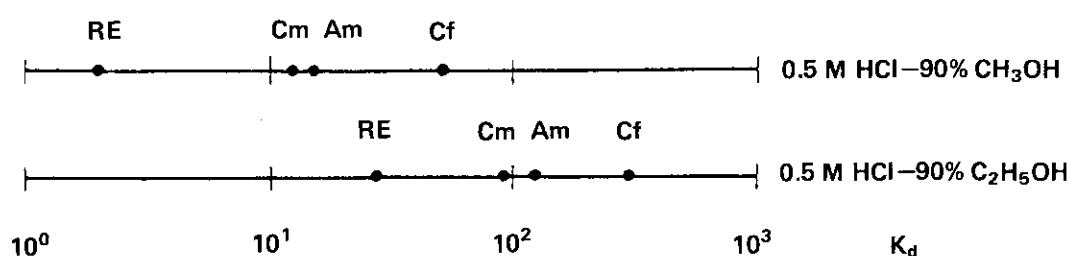

Fig. 4.5 Comparison of the anion-exchange distribution coefficients in CH₃OH and C₂H₅OH.

4.6 Separation procedures

4.6.1 Rapid separation of Cf and its α -counting source preparation

Figure 4.6 shows typical elution curves for the separation of Cf from Am+ Cm, Cs, Sr, the rare earths, 6 mg of Al (catcher foil) and 5 mg of U (target material) with HCl-alcohol media. The column used had a 1.5-mm inner diameter and was filled with 140 mg of CA08S resin to a length of 14 cm. The separation was performed at 90°C with a flow rate of 6.6 cm/min.

Aluminium and Cs passed through the column with 1 ml of 0.5 M HCl-90% C₂H₅OH solution and then Sr, Y and the rare-earth elements were eluted with 1.5 ml of the 0.5 M HCl-90% CH₃OH eluent, followed by the elution of Cm and Am with 2.5 ml of the same eluent. Californium was eluted within the first several drops of 0.5 M HCl-80% CH₃OH solution. Uranium was finally eluted with 0.5 ml of 0.1 M HCl solution.

The Cf fraction was directly deposited as a circle having a diameter of about 5-7 mm at the centre of a tantalum disk of ϕ 24 mm \times 0.05 mm thick by evaporating several drops of the effluent. The α -ray spectrum observed after flaming of the disk is shown in **Fig. 4.7**. The high resolution 17.7 keV in FWHM, was obtained even with high geometry (placed at 5 mm from detector). The total chemical yield of Cf was more than 99%.

The whole procedure including the isolation of Cf and the source preparation for α -ray spectrometry was completed within 10 min.

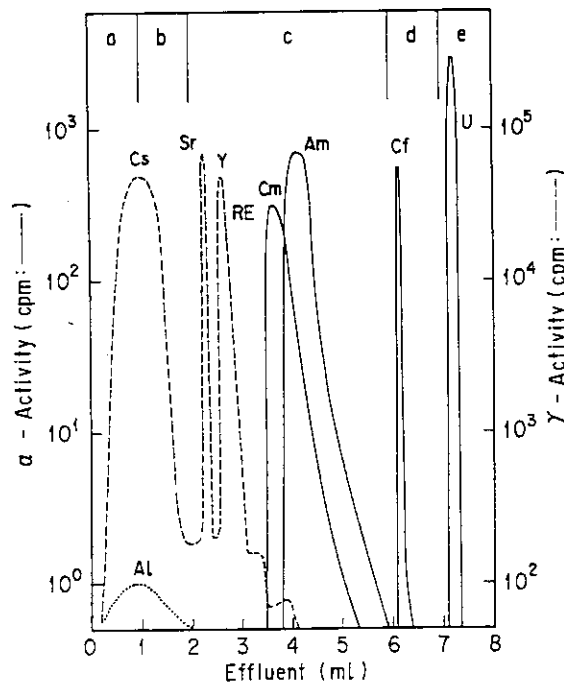

Fig. 4.6 Separation of Cf from Am+Cm, main FP, Al (6 mg) and U (5 mg) with HCl-alcohol media at 90°C. Resin: CA08S (140 mg), a: sample solution (0.1 ml aqua regia+1 ml C₂H₅OH), b: 1 ml 0.5 M HCl-90% C₂H₅OH, c: 4 ml 0.5 M HCl-90% CH₃OH, d: 1 ml 0.5 M HCl-80% CH₃OH, e: 1 ml 0.1 M HCl, flow rate: 6.6 cm/min.

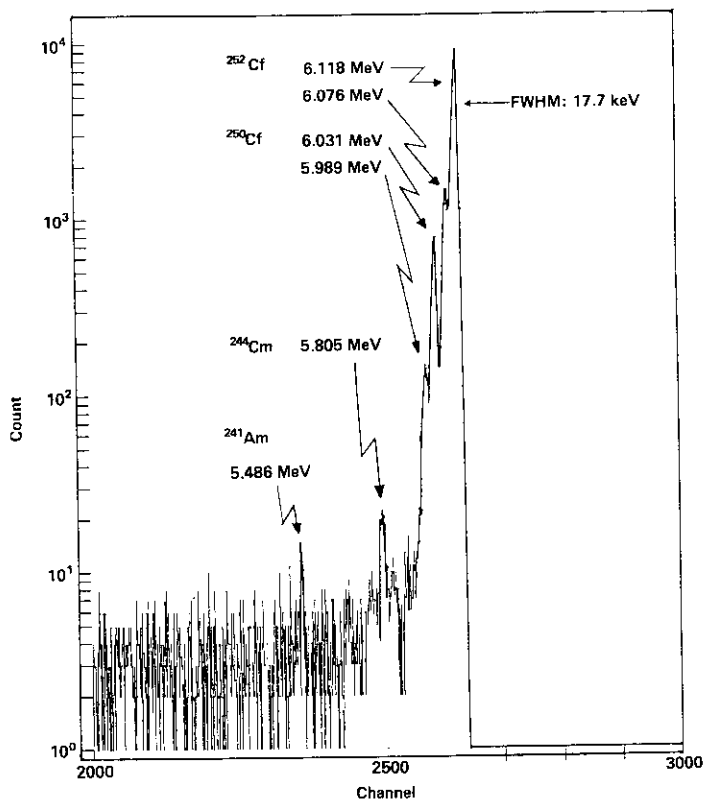

Fig. 4.7 Alpha-ray spectrum of the Cf fraction.

4.6.2 Rapid separation of Bk

Figure 4.8 shows elution curves for the separation of Bk using the 0.5 M HCl-90% CH₃OH medium at 90°C. A fluoroplastic column of 1.5-mm inner diameter packed with 74 mg of CA08S resin was used. Berkelium was separated from the other components, ²⁴²Cm (reaction product), ²⁴¹Am (target), ²⁵²Cf (tracer), Al (catcher foil) and main fission products.

The distribution coefficient of Bk(III) was about 30 in the medium, and the separation factors of Bk/Am and Cf/Bk were 1.6 and 1.5, respectively. The separation factor of Cf/Am was somewhat smaller than the value described in Section 4.3. This was attributed to the presence of nitrate residue in the loading solution. The collective separation factors relative to Cm are shown in **Fig. 4.3**. The adsorption behaviour of Bk was predicted for different acidities of media because the separation factors of transplutonium elements were almost constant. The elution order of Bk is similar to that in concentrated chloro-complex solutions such as 13 M HCl and 10 M LiCl [Tho 54, Hul 61]. Based on the chemical similarity of tri-valent actinide ions, the adsorbed species of Bk is considered to be the same as Am, Cm and Cf in the concentrated chloride solutions as discussed in Section 4.3; that is Bk(Cl)₆³⁻.

Figure 4.9 diagrams the procedure for rapid separation of Bk from the material of an americium target and an aluminium-catcher foil. The salt-free counting source of Bk was quickly prepared for α - and X-ray spectrum measurements by directly evaporating the first several drops of 0.5 M HCl-80% CH₃OH effluent. The X-ray spectrum of the fraction is shown in **Fig. 4.10**. The main peaks are X-rays $K_{\alpha 1}$, $K_{\alpha 2}$ and $K_{\beta 1}$ of Cm and Ta (which was the backing material). The α -ray spectrum of the Bk fraction was also measured. The energies of the main α -ray peaks agreed with those reported for ²⁴³Bk. The time required for the separation and the counting-source preparation was about 5 min.

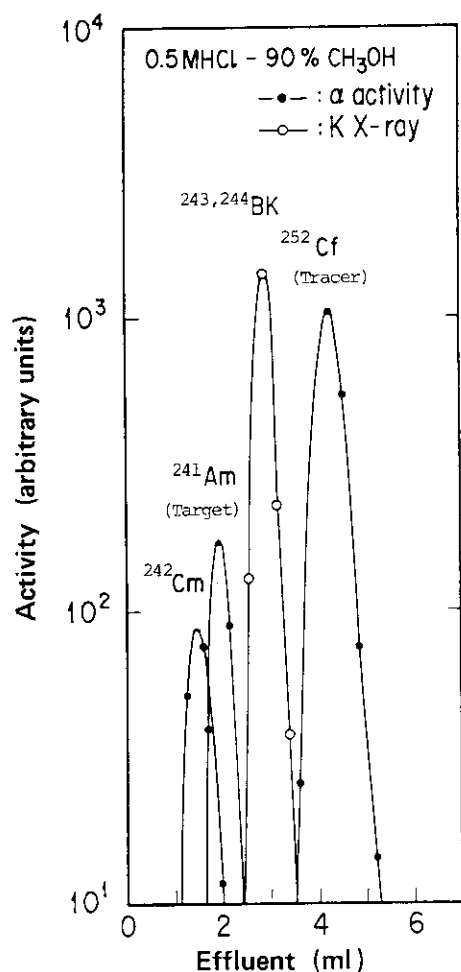

Fig. 4.8 Elution curves for anion-exchange separation of Bk with HCl-CH₃OH medium at 90°C from an aluminium-catcher foil after irradiation. Column bed: ϕ 1.5 mm \times 10 cm, resin: CA08S (74 mg), sample solution: 0.1 ml conc. HCl + 1 ml C₂H₅OH, flow rate: 8.5 cm/min.

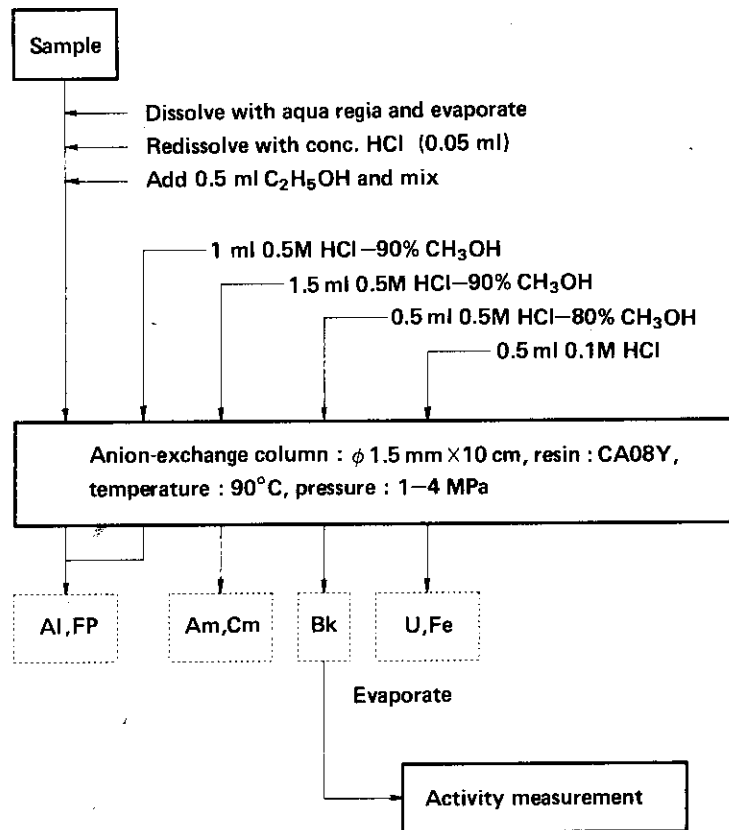

Fig. 4.9 Flow diagram for rapid separation of Bk from an aluminium-catcher foil.

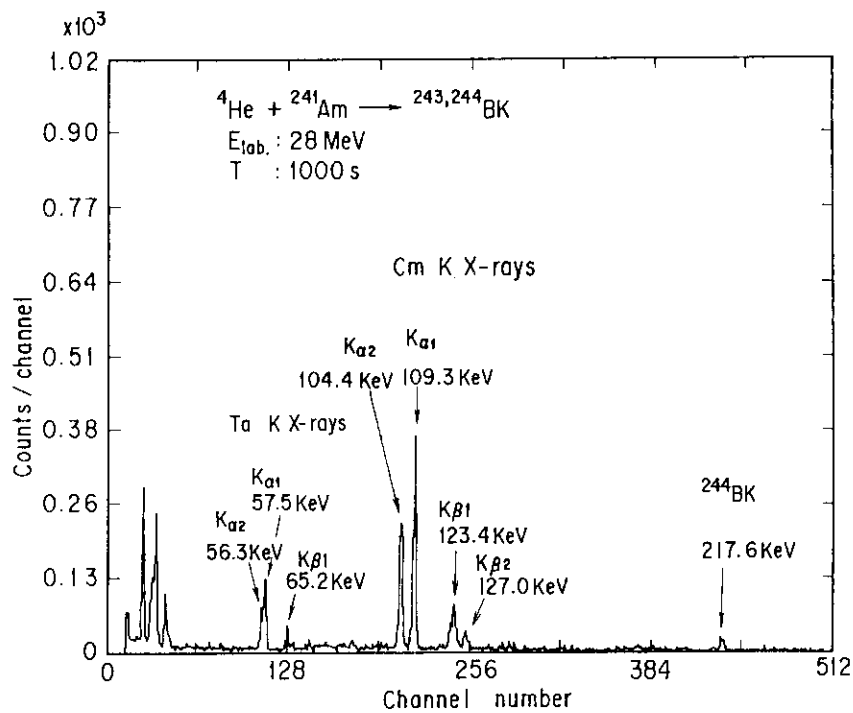

Fig. 4.10 X-ray spectrum of the Bk fraction separated by anion exchange with HCl-CH₃OH media at 90°C.

4.6.3 Rapid separation of Fm

Figure 4.11 shows the anion-exchange elution curves of the actinides produced by the $^{12}\text{C} + ^{242}\text{Pu}$ reaction with 0.5 M HCl-90% CH_3OH mixed eluent with a flow rate of about 15 cm/min at 90°C. The column consisted of 90 mg of CA08S resin in a ϕ 1.5 mm \times 10 cm long tube. The isotope ^{250}Fm was eluted at almost the same position as ^{246}Cf but was separated from the other actinides; Pu (target), Am and Cm (reaction products). The eluting position of Am was determined from the α activity of ^{242}Cm , the decay product of ^{242}Am . Table 4.2 shows the distribution coefficients and the separation factors of trans-plutonium nuclides under these eluting conditions. The separation factor of Cf/Am was smaller than the value obtained in Section 4.3. That may be attributed to the presence of nitrate residue in the sample solution.

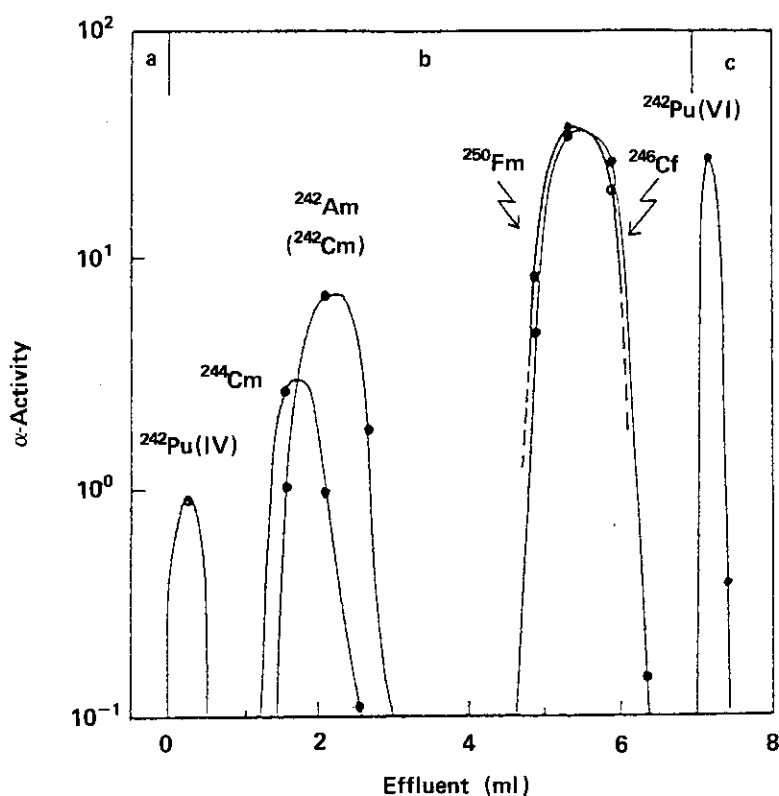

Fig. 4.11 Elution curves of the actinide nuclides produced by the $^{12}\text{C} + ^{242}\text{Pu}$ reaction with anion exchange in 0.5 M HCl-90% CH_3OH medium. a: sample solution (concentrated HCl+ CH_3OH), b: 0.5 M HCl-90% CH_3OH , c: 0.1 M HCl.

Table 4.2 Distribution coefficients (K_d) and separation factors (α) of the transplutonium elements in 0.5 M HCl-90% CH_3OH medium at 90°C.

	Cm	Am	Fm	Cf
K_d	19	23	57	58
α	1.2	2.5	1.0	

Adsorption of Fm is considered to be similar to that of Cf in different concentrations of hydrochloric acid solution, since the separation factors between the transplutonium elements are nearly constant. Einsteinium might show anion-exchange behaviour similar to Fm. It is known that the K_d value of Es is slightly smaller than that of Cf in 20% methanol solution saturated with hydrogen-chloride gas [Mor 66] and also in concentrated lithium chloride solution [Hul 61].

The procedure applied to separate Cf from Am + Cm and rare earths was thus the same procedure as that used for the separation of Fm: After eliminating Al, Pu(IV), Am, Cm and major fission products with 4 ml of the 0.5 M HCl-90% CH₃OH medium, ²⁵⁰Fm and ²⁴⁶Cf were eluted within the first several drops of 0.5 M HCl-80% CH₃OH medium, while Pu(VI), U(VI) (target materials) and Fe (impurity) were retained in the column. The Fm + Cf fraction was easily evaporated on a tantalum disk and counting sources suitable for α -ray spectrometry were rapidly prepared.

5. Cation-Exchange Separation with the Mixed Media of Hydrochloric Acid and Methanol at Elevated Temperature (for Pre-Separation)

5.1 Introduction

The tri-valent transplutonium and rare-earth elements are strongly adsorbed on cation-exchange resins from low concentration solutions of mineral acid [Dia 54, Str 60, Gri 62, Str 65]. The adsorption of those elements is enhanced by adding organic solvents to the mineral acid solutions [Gri 62, Kor 66b, Kor 67a, Kor 67b, Kor 68, Str 73, Gus 84, Gus 85]. Therefore, the cation-exchange method, using mixed media of mineral acid and organic solvent, has a great advantage of effective concentration of the transplutonium fraction. Further, the method enables the separation of the transplutonium elements from many other ones [Kor 67a, Kor 67b, Str 69, Gus 72, Gus 84, Gus 85].

Figure 5.1 compares the K_d values of various elements in a system of cation-exchange resins with selected eluents [Str 60, Str 65, Kor 67a, Kor 67b, Str 69]. The distribution coefficients of U, Fe and Cu decrease with increasing concentration of organic solvent, while the K_d value of Ce remains very high [Fri 62, Kor 67a]. For example, in a mixture of 1.2 M HCl-90% CH₃OH (or acetone), the K_d values of U, Fe and Cu are all less than unity but the K_d of Ce is greater than 10^3 .

It has been also reported that the separation factors between Y and Al are 10 in 3 M HCl-60% C₂H₅OH mixture and 2.9 in 3 M HCl solution [Str 69]. The rare-earth and transplutonium elements would be similar to Ce and Y in behaviour.

Recently, GUSEVA and TIKHOMIROVA have separated Am and Cm from several fission products by cation exchange with a mixture of C₂H₅OH and 1 M HCl or 1 M HNO₃ [Gus 84]. Therefore, it might be possible to separate efficiently the transplutonium elements from uranium-targets and catcher-foil materials (Al and Cu).

In Chapter 3, the anion-exchange method of separating the transplutonium elements from each other with mixed media of nitric acid and methanol was described. In Chapter 4, the anion-exchange separation of the transplutonium elements in a few groups from the rare earths with mixed media of hydrochloric acid and methanol was discussed. Mutual separation of the transplutonium elements with mixtures of nitric acid and methanol were not effective for the elements heavier than Cf. For mutual separation of these elements, a cation-exchange method with α -hydroxyisobutyrate (2-hydroxy-2-methylpropionate) solution is more effective [Cho 56a, Gat 59, Mik 87].

This chapter addresses rapid cation-exchange separation of the transplutonium elements at elevated temperature. Cation exchange with mixed media of hydrochloric acid and methanol can be used to remove the large amount of uranium-targets and/or catcher-foil materials present. The transplutonium elements retained on the ion-exchange resin are then eluted in a group with hydrochloric acid or individually with α -hydroxyisobutyrate solution [Usu 87b, Usu 88a]. Alpha sources might be immediately prepared from the eluted elements.

5.2 Effective removal of uranium target, catcher-foil material and main fission products

To remove the large amounts of U, Cu and Al from the trace amounts of transplutonium elements retained on the cation-exchange column, mixed media of mineral acids and organic solvents were

examined as eluting agents at elevated temperature. On the basis of the K_d values of various elements shown in Fig. 5.1, the mixtures of nitric acid and organic solvents do not appear appropriate because the K_d values of U and Cu are very large which should result in poor separation of the transplutonium elements from the bulk of U and Cu. Also, as described in Section 4.5, the mixtures of acetone and hydrochloric acid should be avoided because acetone reacts with the acid at high temperatures.

On the other hand, the mixed media of hydrochloric acid and methanol would be more promising. Figure 5.2 shows elution curves for the separation of the transplutonium elements (^{241}Am , ^{244}Cm and ^{252}Cf) from 9.5 mg of Cu with a CK08Y resin column. A high flow rate, 10–20 cm/min, was obtained with a pressure below 1 MPa. The temperature was maintained at 90°C during operation. In the elution with 1.3 M HCl–90% CH₃OH mixture, Cu and ^{106}Ru immediately passed through the column without tailing. Subsequently, ^{137}Cs was eluted with the same eluent and ^{90}Sr with 3 M HCl–50% CH₃OH medium. The transplutonium elements were then eluted with 100% yields with 2 ml of 4 M HCl solution. The rare-earth elements (^{90}Y , $^{154,155}\text{Eu}$, ^{147}Pm and $^{144}\text{Ce-Pr}$) were eluted at this time also.

With this separation process, milli-gram quantities of U and Al were quickly eluted from the column with the mixed media of 1.3 M HCl–90% CH₃OH and 3 M HCl–50% CH₃OH, respectively (refer to Sections 5.3 and Fig. 5.3). Iron, a frequent contaminant, introduced from the separation process, was also removed with either of those eluents. Thus, the transplutonium elements obtained were free of macro quantities of metals and the samples for α -activity measurement were prepared with minimal residue by direct drop evaporation of the effluents. The adsorption of the transplutonium elements on the resin was so strong that the presence of an excess quantity of U, Cu, Al and Fe did not affect the recovery of the transplutonium elements.

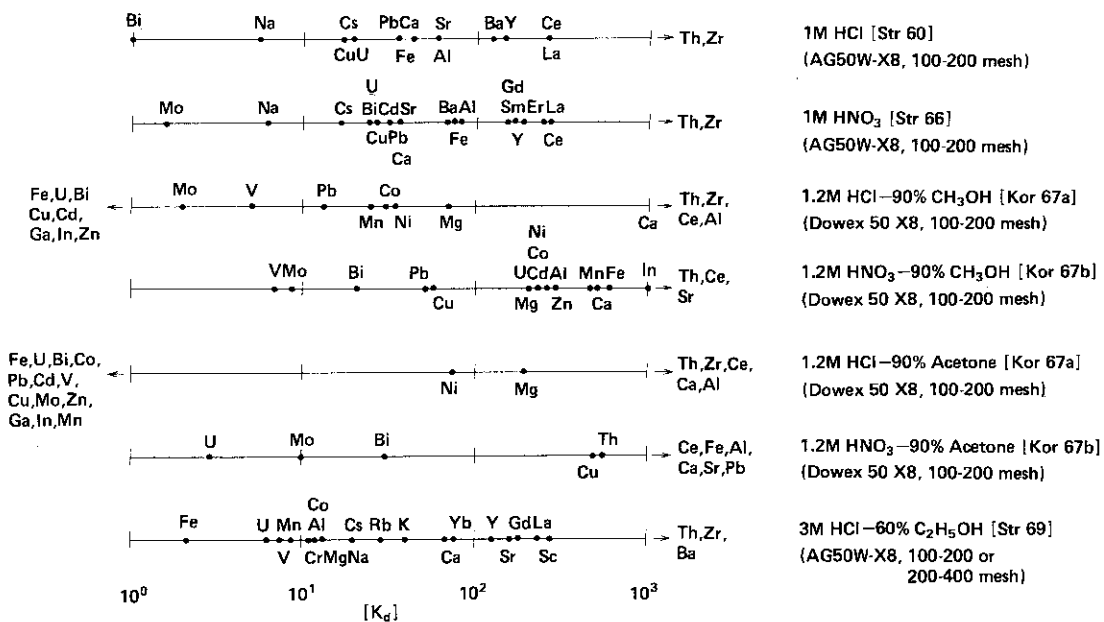

Fig. 5.1 Comparison of the distribution coefficients for cation-exchange resins with selected eluents.

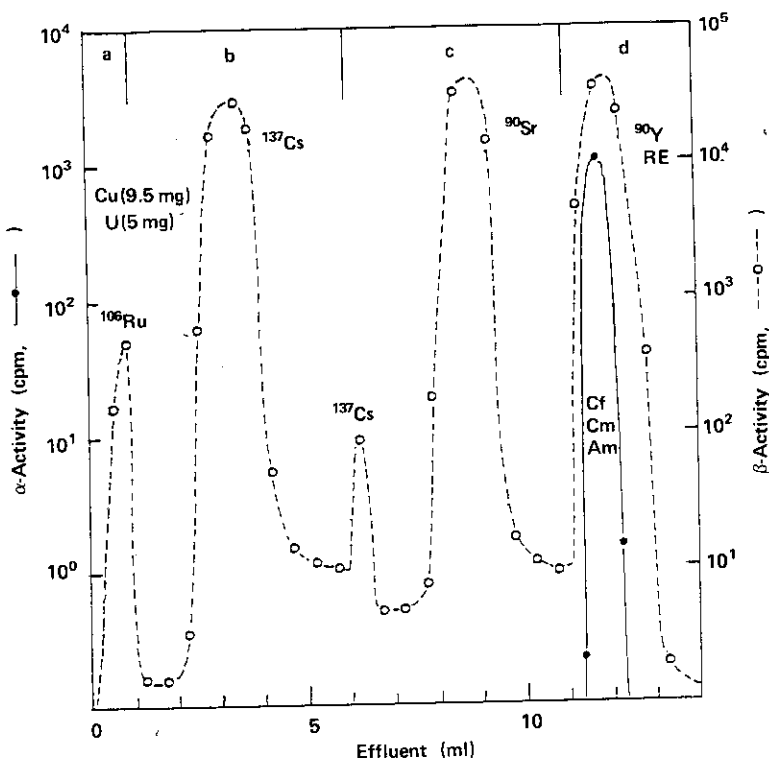

Fig. 5.2 Cation-exchange chromatogram for separation of the transplutonium elements from fission products and a copper foil. Column bed: ϕ 1.5 mm \times 11 cm, resin: CK08Y, flow rate: 10–20 cm/min, temperature: 90°C, a: sample solution (conc. HCl 0.1 ml + CH₃OH 1 ml), b: 1.3 M HCl–90% CH₃OH 5 ml, c: 3 M HCl–50% CH₃OH 5 ml, d: 4 M HCl 3 ml.

5.3 Group or mutual separation of the transplutonium elements

The transplutonium elements would be separated from the rare-earth elements as an individual group [Str 50a, Dia 54, Cho 60, Cho 62, Ume 74] by replacing the 4 M HCl eluent with concentrated HCl at the last stage of the process shown in Fig. 5.2.

Figure 5.3 shows elution curves of the group separation after removing the macro amounts of U (5 mg) and Al (5 mg) with CPK08P resin at 90°C and flow rate of 20–30 cm/min. After eluting U and ¹³⁷Cs with the 1.3 M HCl–90% CH₃OH eluent, Al was completely removed from the column with 2 ml of 3 M HCl–50% CH₃OH eluent. The transplutonium elements were then quantitatively eluted within 0.5 ml volume of concentrated hydrochloric acid solution. The rare-earth elements were subsequently eluted with the same eluent. This method was quite suitable for separation of the transplutonium elements in a group from rare-earth elements and the target and the catcher-foil materials.

Mutual separation of the transplutonium elements from the co-existing materials was attempted by elution with α -hydroxyisobutyrate solution instead of concentrated hydrochloric acid as in the process described above.

Figure 5.4 shows elution curves of the mutual separation of the transplutonium elements in the presence of some fission products and 1.5 mg of U using a CK08S resin column at 90°C. The flow rate of eluents was maintained between 2–6 cm/min. After removing the U and Al, the resin form was converted from H–R to NH₄–R by passing 1 ml of 0.5 M NH₄Cl solution and 1 ml of water through it. Californium, Cm, Am and some rare earths were mutually separated with 0.25 M α -hydroxyisobutyrate solution. The elution position of trans-californium elements was checked with ²⁵⁰Fm. It was confirmed that Fm was

eluted in front of the californium position. **Figure 5.5** shows the flow diagram for mutual transplutonium separation by single-column operation.

The effluents were directly evaporated on tantalum disks to measure α activities. Since a little residue remained after exposing the source disks in a gas-burner flame, poor resolution of the peaks in the α -ray spectrum was obtained (FWHM: ≥ 50 keV).

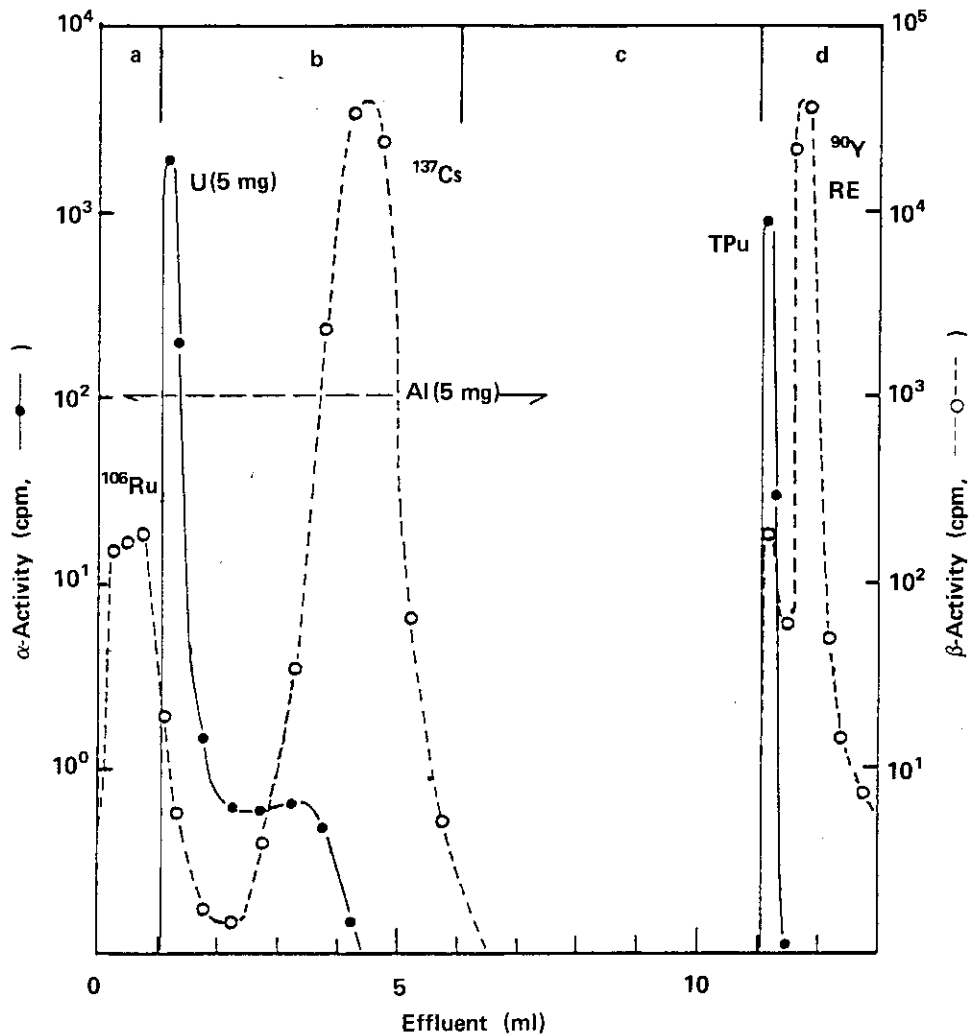

Fig. 5.3 Cation-exchange chromatogram for group separation of transplutonium and rare-earth elements from a uranium target and an aluminium foil. Column bed: ϕ 1.5 mm \times 14 cm, resin: CPK08P, flow rate: 20–30 cm/min, temperature: 90°C, a: sample solution (conc. HNO₃ 0.1 ml + CH₃OH 1 ml), b: 1.3 M HCl–90% CH₃OH 5 ml, c: 3 M HCl–50% CH₃OH 5 ml, d: conc. HCl 2 ml.

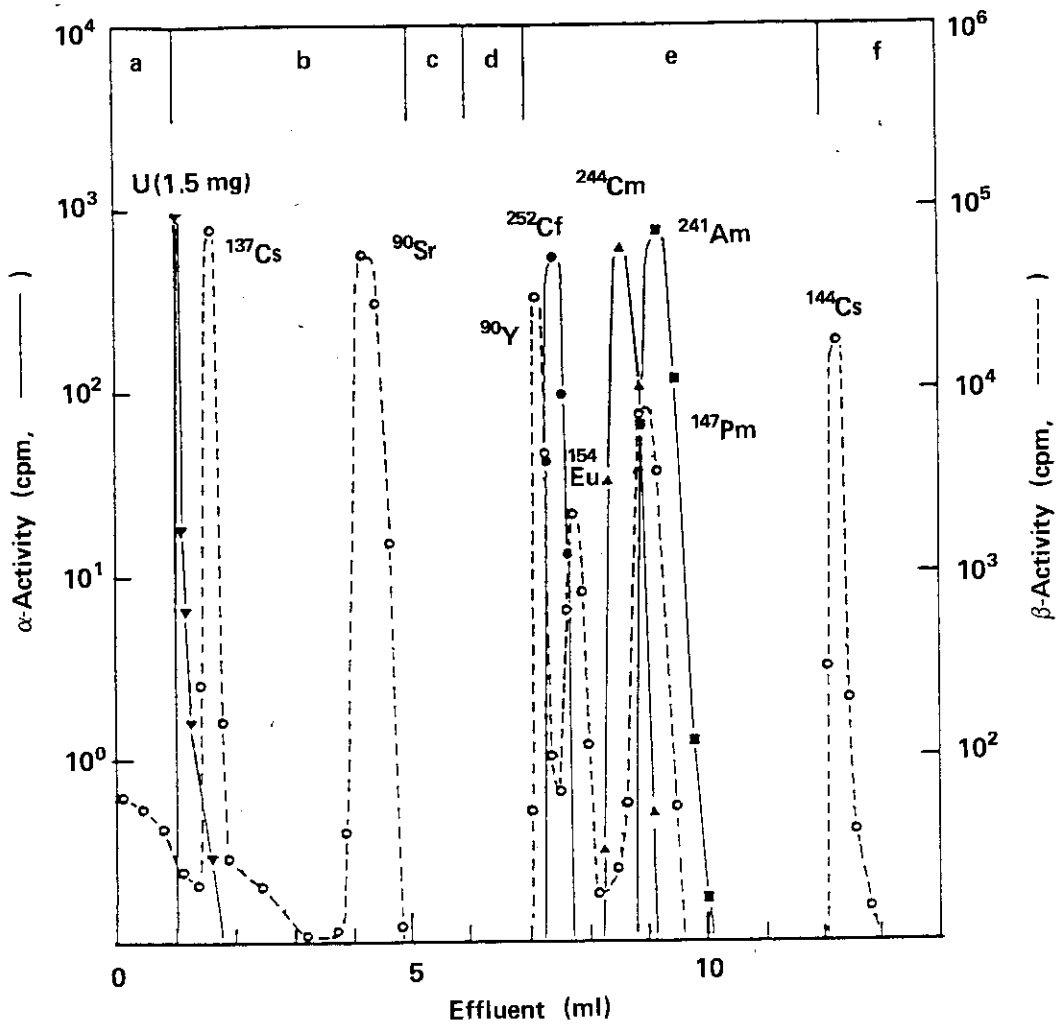

Fig. 5.4 Cation-exchange chromatogram for mutual separation of the transplutonium elements from fission products and a uranium target. Column bed: ϕ 1.5 mm \times 8.7 cm, resin: CK 08S (108 mg), flow rate: 2–6 cm/min, temperature: 90°C, a: sample solution (conc. HCl 0.1 ml + CH₃OH 1 ml), b: 3 M HCl–50% CH₃OH 4 ml, c: 0.5 M NH₄Cl 1 ml, d: H₂O 1 ml, e: 0.25 M α -hydroxyisobutyrate (pH 4.65) 5 ml, f: 0.25 M α -hydroxyisobutyrate (pH 5.05) 2 ml.

固図0501

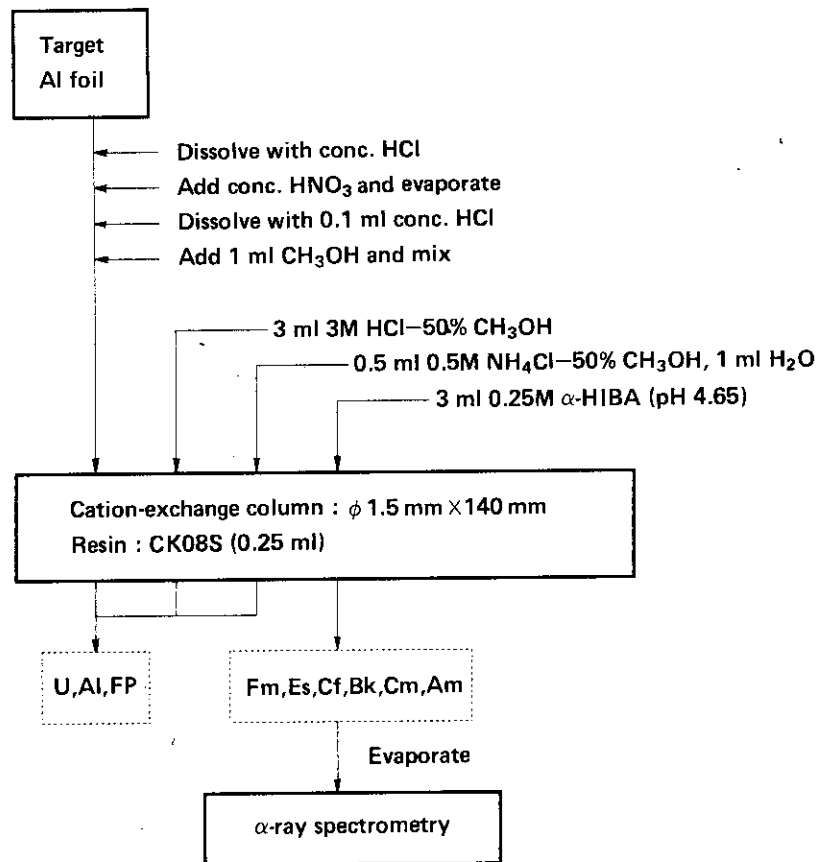

Fig. 5.5 Flow diagram for mutual separation of transplutonium elements from a heavy-ion bombarded uranium target with an aluminium foil by single cation-exchange column.

5.4 Rapid separation of the transplutonium nuclides from heavy-ion bombarded uranium targets

Uranium targets bombarded with 88-MeV ¹⁶O-ion beam of about 150 particle nA for 30 min in the JAERI tandem accelerator [Shi 84, Shi 85a] were treated as described in the following. The target assembly comprised of 1.4 mg of ²³⁸U and 4 mg of aluminium foil was dissolved with concentrated HCl solution in a 5-ml beaker under an infrared lamp. Concentrated HNO₃ was added to the beaker for complete dissolution and oxidation. The separation flow diagram is shown in Fig. 5.6. The source on the tantalum disk was ignited in a gas-burner flame and immediately submitted to α-ray spectrometry. Figure 5.7 shows an α-ray spectrum of the transplutonium fraction. The resolution of the ²⁵⁰Fm peak was about 50 keV in FWHM. The procedure, including separation and sample preparation for α-ray spectrometry, was completed within 15 min.

The mutual separation of transplutonium elements shown in Fig. 5.5 was also applied to the study of heavy-ion reactions, where ²⁵⁰Fm and ²⁴⁶Cf were chemically identified. However, the separation of ²⁵⁰Fm and ²⁴⁶Cf was not effective. It took about 30 min for the separation and the source preparation.

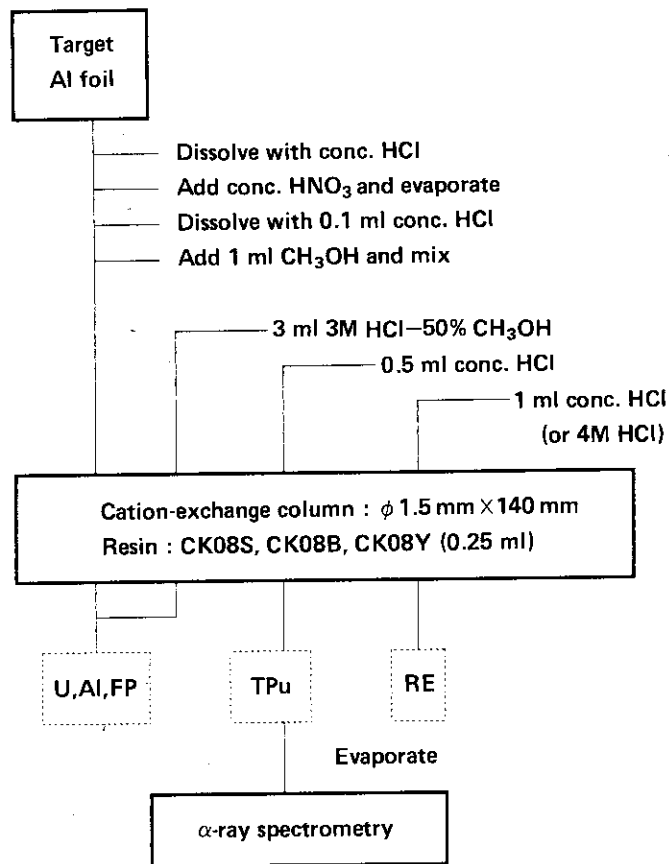

Fig. 5.6 Flow diagram for rapid group-separation of transplutonium elements.

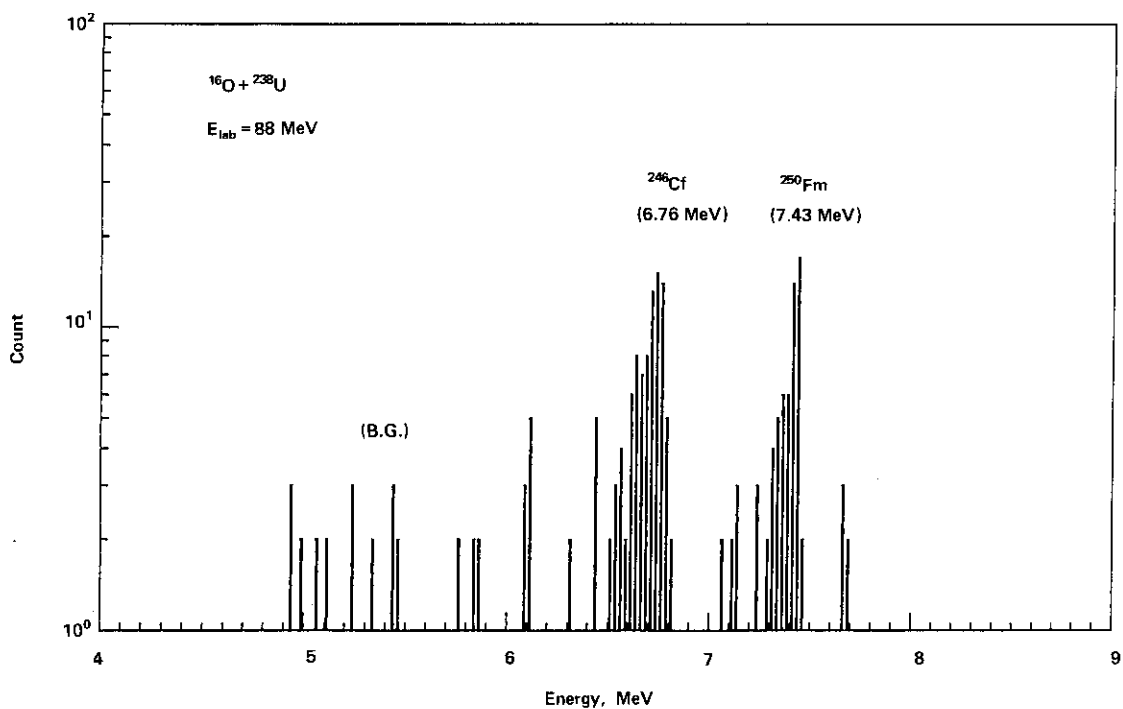

Fig. 5.7 Alpha-ray spectrum of the transplutonium fraction separated from a ^{16}O bombarded ^{238}U target by the cation-exchange method.

6. Application of the Separation System

6.1 Synthesis of short-lived actinide nuclides by heavy-ion reactions

6.1.1 Actinide nuclides synthesized by the $^{16}\text{O} + ^{238}\text{U}$ reaction

Twenty-one nuclides, ^{250}Fm , $^{244,245,246}\text{Cf}$, $^{240,242}\text{Cm}$, $^{238,239}\text{Np}$, $^{237,239}\text{U}$, $^{225,226,227,228}\text{Th}$, $^{224,225}\text{Ac}$ and $^{221,222,223,224,225}\text{Ra}$, have been observed by bombardment of ^{238}U targets with ^{16}O ions. After purification with the ion-exchange methods described in Chapters 2, 3, 4 and 5, these nuclides were identified from their chemical behaviour and decay properties. In addition, the excitation functions for formation reactions have been studied [Shi 83, Shi 84, Shi 85a, Shi 85b].

Targets of 99.98% ^{238}U were prepared by electrodeposition from 2-propanol solution onto an aluminium-backing foil of $7\ \mu\text{m}$ thick [Aum 74, Oka 86]. The thickness of the targets varied from 0.3 to $2\ \text{mgU}/\text{cm}^2$. The target assemblies were made of an aluminium foil for degrading the beam energy, the uranium target, and an aluminium foil of $7\ \mu\text{m}$ thick for catching the recoiling nuclei, as shown in Fig. 6.1. The target assembly was irradiated with ^{16}O ions of 85–130 MeV and about 150 nA for 0.5 to 3 h in the JAERI tandem accelerator.

Immediately after bombardment, α -ray spectra of the aluminium-catcher foils were directly measured. Figure 6.2 shows typical α -ray spectra of a foil, which caught the nuclei produced by bombardment of a thin ^{238}U target ($0.3\ \text{mg}/\text{cm}^2$) with ^{16}O ions. The half-life of the 6-MeV peak was measured to be 15 ± 2 min. The 7.4-MeV peak might be from ^{250}Fm ($T_{1/2}$: 30 min, α : 7.43 MeV) [Ami 57, Aka 66]. In order to identify such nuclides, the chemical separation was necessary.

To perform ion-exchange separation, the target ($\leq 5\ \text{mg U}$) and the catcher foil ($\leq 10\ \text{mg Al}$) were dissolved with concentrated HCl solution in a 5-ml beaker, heated under an infrared lamp. Concentrated HNO_3 was then added to the solution to complete dissolution and oxidation. The solution was immediately evaporated to near dryness.

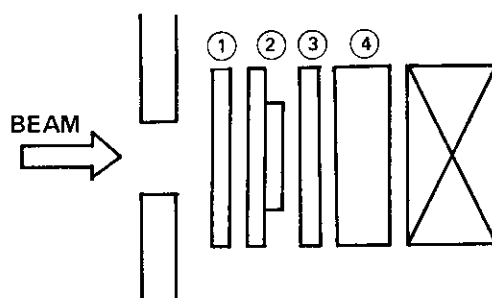

- ① : Al ($7\ \mu\text{m}$)
- ② : Target, ^{238}U (99.98 w/o) + Al($7\ \mu\text{m}$)
- ③ : Al catcher foil ($7\ \mu\text{m}$)
- ④ : Al ($100\ \mu\text{m}$)

Fig. 6.1 ^{238}U target assembly.

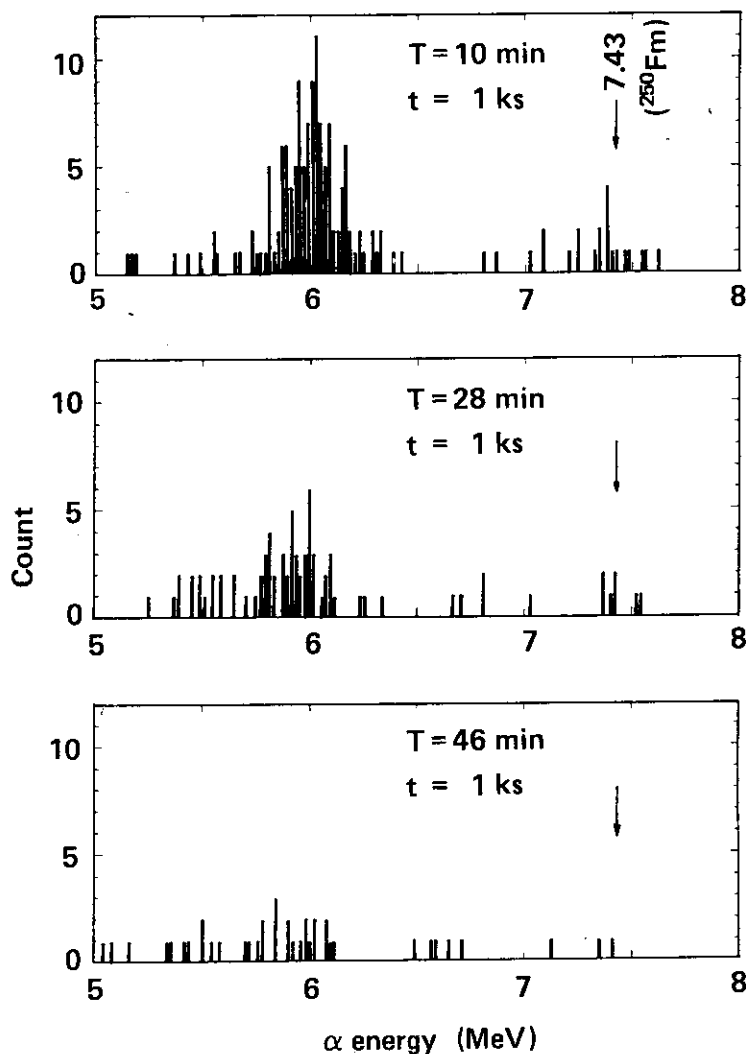

Fig. 6.2 Typical α -ray spectra of an aluminium-catcher foil after the bombardment of ^{238}U target with 92 MeV ^{16}O beams. T gives the starting time of counting after the end of irradiation, t the counting duration.

i) Separation of Fm + Cf and Cm + Am from a ^{238}U target by anion exchange with the mixed media of hydrochloric acid and methanol

The anion-exchange separation with the mixed media of hydrochloric acid and methanol is the most suitable method for separation of Fm + Cf from the target and catcher foils and for the preparation of a counting source for α -ray spectrometry as described in Chapter 4. A flow diagram of the separation procedure is shown in Fig. 6.3. The evaporation residue of the sample solution was redissolved with concentrated HCl and the solution volume was adjusted to about 0.1 ml. Then 1 ml of $\text{C}_2\text{H}_5\text{OH}$ was added to the solution to prepare a column-loading solution. After charging the sample solution to a column packed with 0.25 ml of CA08Y or CA08B resin, the Al and main fission products including the rare-earth elements were washed with 1 ml of 0.5 M HCl-90% CH_3OH medium, and the Cm and Am were eluted with 3 ml of 0.5 M HCl-90% CH_3OH medium. The Cm + Am fraction was received in a 5-ml beaker, partially evaporated, deposited and mounted on a tantalum disk (ϕ 24 mm \times 0.05 mm thick) by heating on a hot plate for α -ray spectrometry. Alpha-activity was barely observed during the short-period countings, while ^{240}Cm ($T_{1/2}$: 27 d, α : 6.29 MeV) and ^{242}Cm ($T_{1/2}$: 161.35 ± 0.30 d, α : 6.11 MeV) [Usu 81] were detected during the long-period counting.

Californium and Fm were then eluted with 0.5 ml of 0.5 M HCl–80% CH₃OH eluent. The first 15–20 drops of the 0.5 M HCl–80% CH₃OH effluent were directly deposited and dried at the centre of another heated tantalum disk. The disk was exposed to a gas-burner flame and immediately subjected to α -ray spectrometry. **Figure 6.4** shows an α -ray spectrum of the Fm + Cf fraction. Any α emitters, except for Cf and Fm, were not observed in the 4-ks counting. Finally, the target U was eluted with 0.5 ml of 0.1 M HCl solution together with Fe present. The whole process was completed within 10–15 min.

The α energies of peaks in the spectrum of the Fm + Cf fraction and their half-lives fairly agreed with the reported values of ²⁴⁶Cf ($T_{1/2}$: 35.7 h, α : 6.758 MeV) [Hul 51, Fri 63] and ²⁵⁰Fm ($T_{1/2}$: 30 min, α : 7.43 MeV) [Ami 57, Aka 66]. **Figure 6.5** shows the decay curve for the 7.4-MeV peak. The measured half-life was 31 ± 5 min.

When the bombardment was performed with ¹⁶O ions having an energy higher than about 95 MeV, ²⁴⁴Cf ($T_{1/2}$: 20 min, α : 7.21 MeV) and ²⁴⁵Cf ($T_{1/2}$: 43.6 min, α : 7.14 MeV) were detected in the fraction.

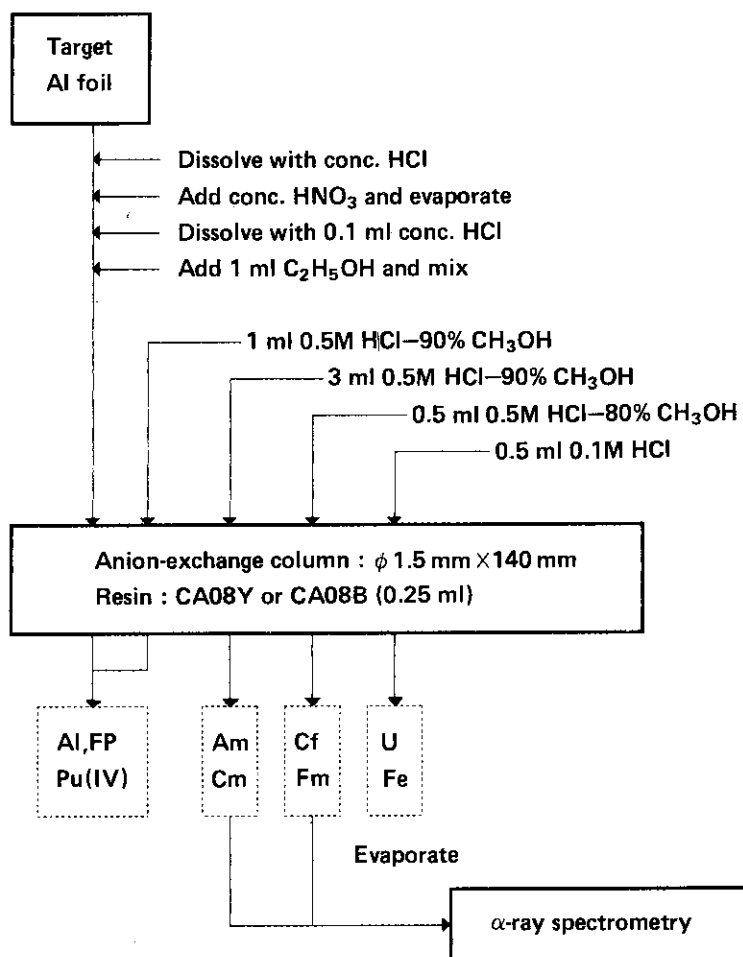

Fig. 6.3 Diagram for rapid anion-exchange separation of Am+Cm and Cf+Fm from target material (U or Pu) and an aluminium-catcher foil with HCl–CH₃OH media.

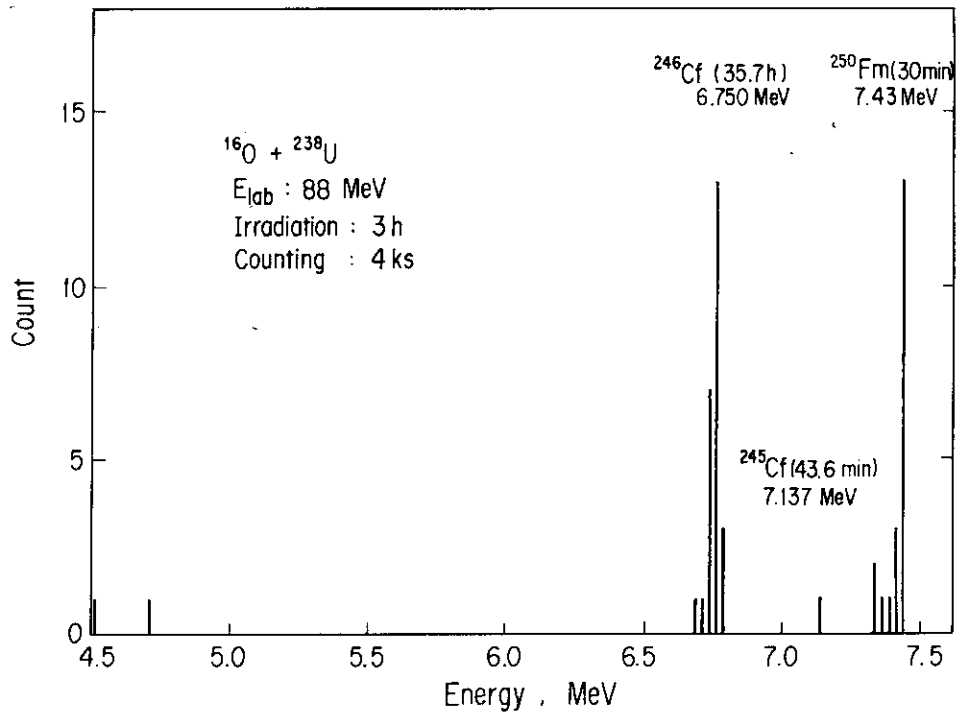

Fig. 6.4 Typical α -ray spectrum of the Cf+Fm fraction purified by the anion-exchange method with HCl-CH₃OH media.

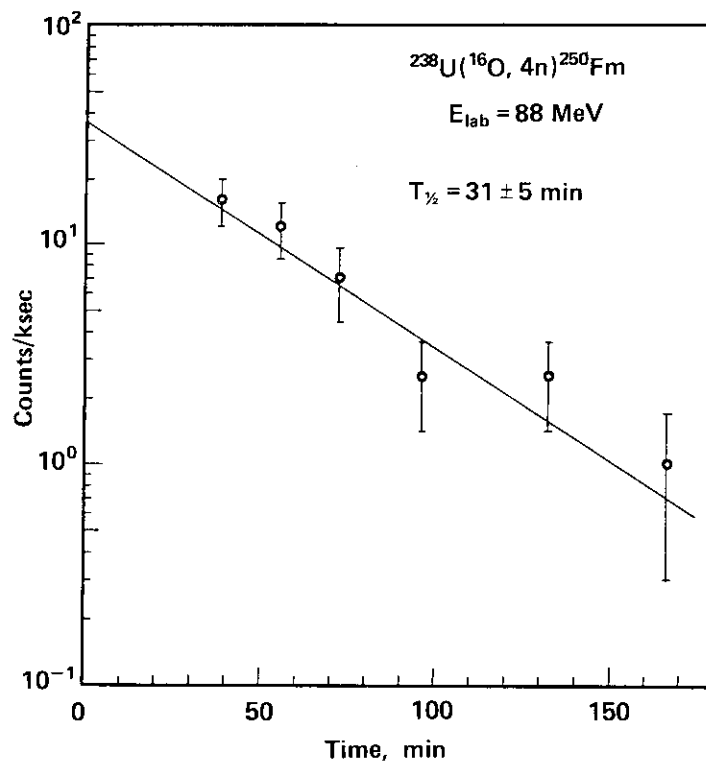

Fig. 6.5 Decay curve of 7.4-MeV α emitter in the transplutonium fraction after ion-exchange separation.

ii) Separation of Fm and Cf from a ^{238}U target by anion exchange with the mixed media of nitric acid and methanol

Anion-exchange chromatography with the mixed media of nitric acid and methanol enables the separation of Fm and Cf from each other as described in Chapter 3. The evaporation residue of the sample solution was redissolved with concentrated HNO_3 . The volume was adjusted to about 0.06 ml and 0.6 ml of $\text{C}_2\text{H}_5\text{OH}$ was added to the solution for column loading. After charging the sample solution to a column packed with 0.25 ml of CA08Y resin, the target and catcher-foil materials and main fission products except for the lanthanoids were washed out with 6 ml of 1M HNO_3 -90% CH_3OH solution.

The nuclides $^{92,93,94}\text{Y}$ ($T_{1/2}$: 3.54 h, 10.1 h, 18.7 min) and $^{140,141}\text{Ba}$ ($T_{1/2}$: 2.8 d, 18.3 min) were eluted with 2 ml of the same eluent and then the trans-curium elements were eluted with 2.5 ml of 0.5 M HNO_3 -90% CH_3OH solution. **Figure 6.6** shows the elution curves. The elution order of lanthanoids in the fraction was ^{159}Gd ($T_{1/2}$: 18.6 h), $^{156,157,158}\text{Eu}$ ($T_{1/2}$: 15.2 d, 15.2 h, 46 min) and $^{153,155,156}\text{Sm}$ ($T_{1/2}$: 46.8 h, 22.4 min, 9.4 h). Since the lanthanoid nuclides were eluted in the reverse order of their atomic number, the 7.43- and 6.76-MeV α emitters were assigned to Fm and Cf. Thus ^{250}Fm and ^{246}Cf were identified by the ion-exchange behaviour and the decay properties described in i) of this section.

The residual lanthanoid nuclides, $^{140,141,142}\text{La}$ ($T_{1/2}$: 40.3 h, 3.9 h, 92.5 min), ^{143}Ce ($T_{1/2}$: 33.0 h), ^{146}Pr ($T_{1/2}$: 24.0 min), ^{149}Nd ($T_{1/2}$: 1.73 h), $^{150,151}\text{Pm}$ ($T_{1/2}$: 2.7 h, 28 h), were eluted with 1 ml of 0.1 M HCl solution.

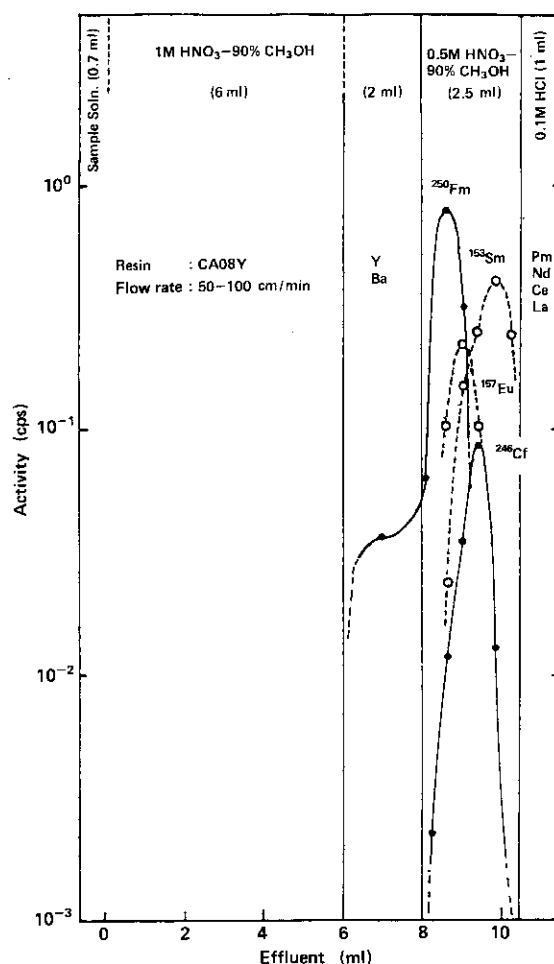

Fig. 6.6 Elution curves of ^{16}O bombarded ^{238}U target by the anion-exchange method with HNO_3 - CH_3OH media.

iii) Separation of Ra, Ac and Th from a ^{238}U target by anion exchange with the mixed media of hydrochloric acid and methanol

Thorium, actinium and radium nuclides were observed in the uranium target bombarded with ^{16}O at 110–130 MeV [Shi 85a, Shi 85b]. Those elements were separated by applying the procedure shown in Fig. 6.7. After eliminating the aluminium foil and main fission products with 2 ml of 1 M HCl–90% CH_3OH solution, the Ra, Ac and Th retained in the column were eluted with 0.5 ml of 0.5 M HCl–80% CH_3OH solution together with transplutonium elements.

Figures 6.8 and 6.9 show α -ray spectra of the fractions. The former spectrum was measured just after separation (ca. 20 min after the irradiation), in which $^{225,226}\text{Th}$ ($T_{1/2}$: 8 min, 31 min) and their decay products as well as $^{244,245}\text{Cf}$ ($T_{1/2}$: 19.7 min, 43.6 min) were identified. In the latter spectrum, obtained from a 60-ks counting one week after the separation, ^{227}Th ($T_{1/2}$: 18.72 d), ^{225}Ac ($T_{1/2}$: 10.0 d), ^{224}Ra ($T_{1/2}$: 3.66 d), their decay products and $^{240,242}\text{Cm}$ ($T_{1/2}$: 27 d, 161 d) were detected.

iv) Excitation functions of the $^{16}\text{O} + ^{238}\text{U}$ reaction

In order to investigate the formation conditions for the actinide nuclides in the reaction system, excitation functions of the $^{16}\text{O} + ^{238}\text{U}$ reaction have been determined by the use of the separation techniques, described in this report [Shi 84, Shi 85a, Shi 85b].

The excitation function for ^{250}Fm formation is shown in Fig. 6.10. The nuclide was effectively produced in the ^{16}O -energy range of 84 to 102 MeV (lab. system). The maximum cross section was about $2 \times 10^{-30} \text{ cm}^2$ when the projectile energy was about 92 MeV.

The excitation functions for the formation of ^{246}Cf , ^{242}Cm , $^{238,239}\text{Np}$ and $^{237,239}\text{U}$ were also obtained [Shi 84, Shi 85a]. Protactinium, U and Np were separated by the anion-exchange method with hydrochloric acid solutions (refer to Appendix B.1 and Fig. B.1). No γ activity that could be ascribed to protactinium nuclides was detected.

Figure 6.11 shows the excitation functions as well as fission-cross section quoted from Viola et al. [Vio 62]. The excitation functions for the formation of $^{225,226,227,228}\text{Th}$, $^{224,225}\text{Ac}$ and $^{223,224}\text{Ra}$ were obtained as a function of the number of neutrons and protons picked up from the target nucleus as shown in Fig. 6.12 [Shi 85a, Shi 85b].

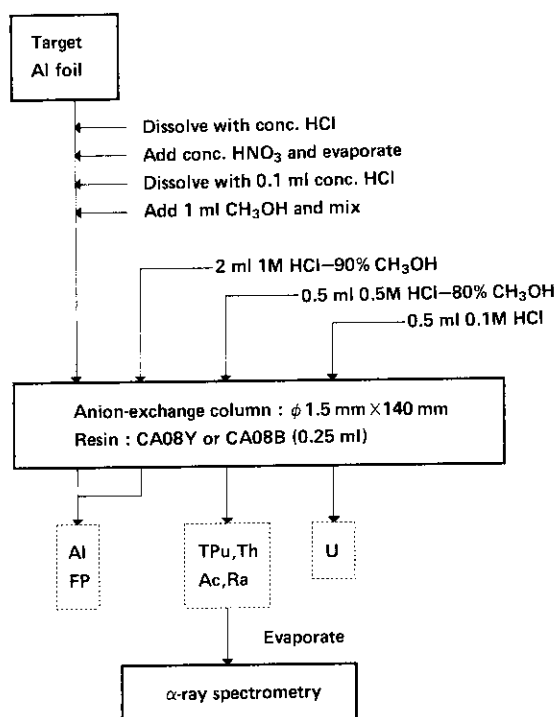

Fig. 6.7 Separation procedures for Th and transplutonium elements from a uranium target and an aluminium-catcher foil using the anion-exchange method with HCl – CH_3OH media.

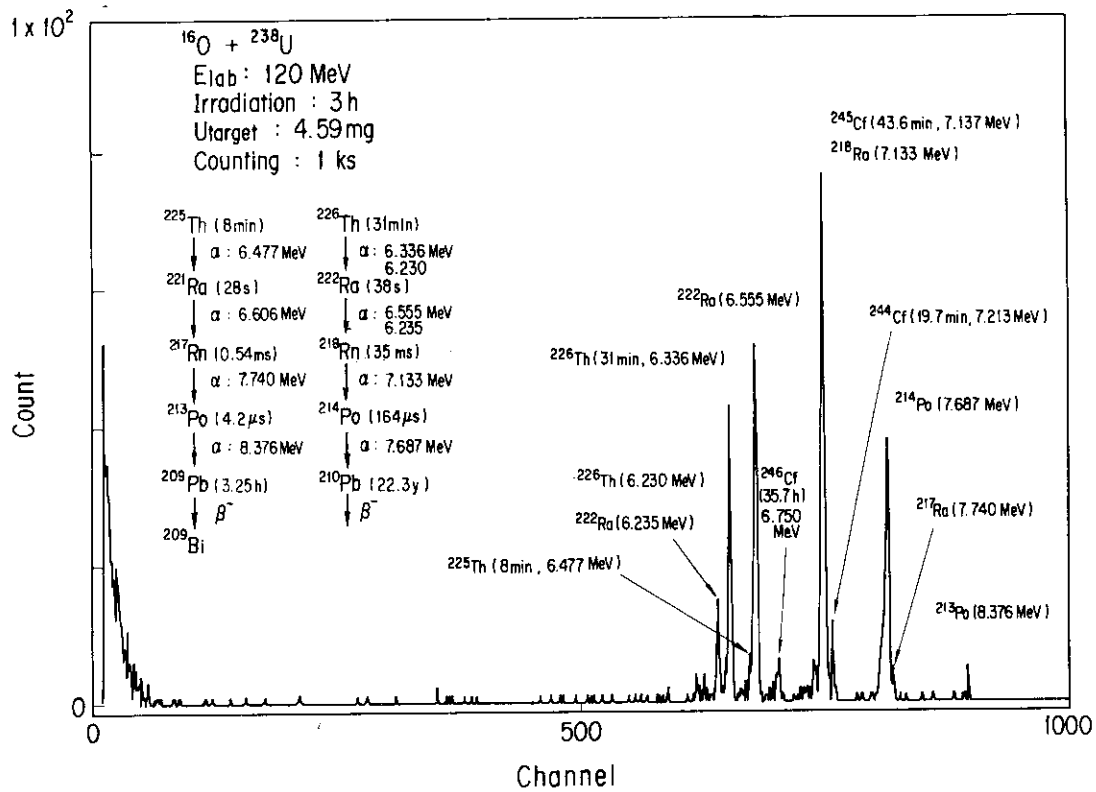

Fig. 6.8 Typical α -ray spectrum of the actinide fraction purified by the anion-exchange method with HCl - CH_3OH media, observed immediately following separation (about 20 min after irradiation).

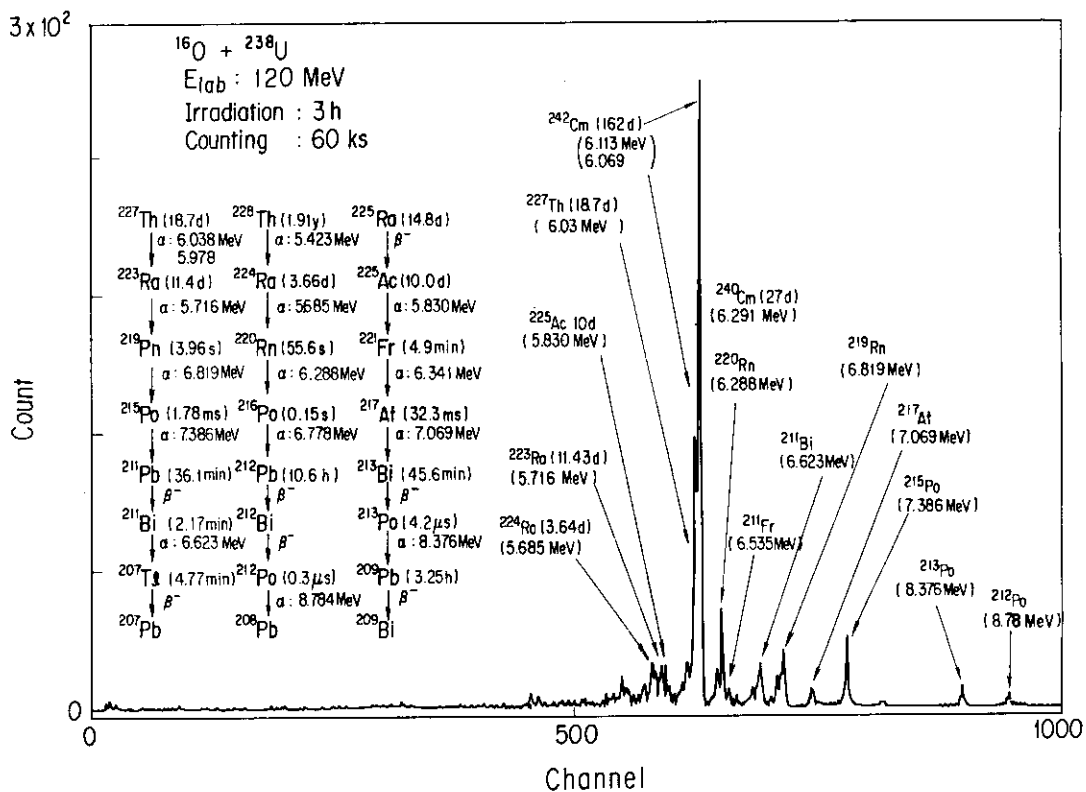

Fig. 6.9 Alpha-ray spectrum of the same actinide fraction observed in long counting duration, 7.4 d after irradiation.

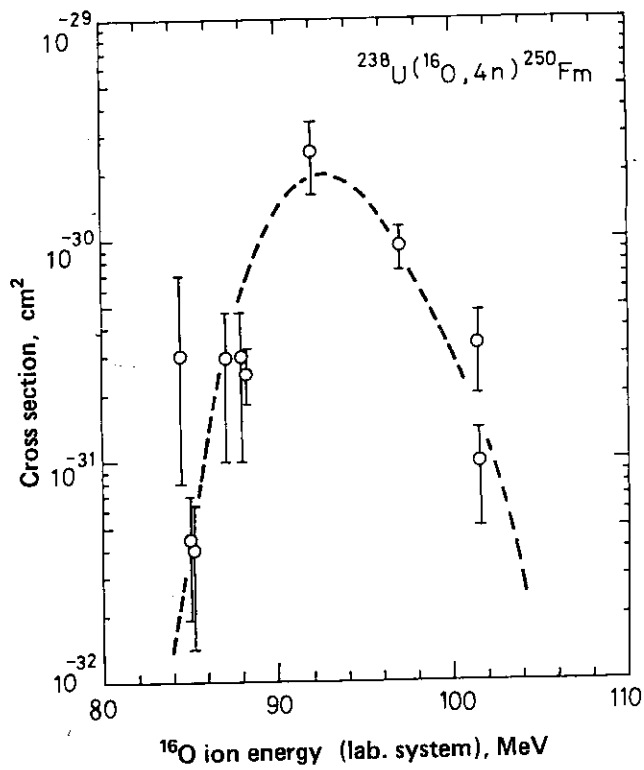

Fig. 6.10 Excitation function of the reaction $^{238}\text{U}(^{16}\text{O}, 4n)^{250}\text{Fm}$.

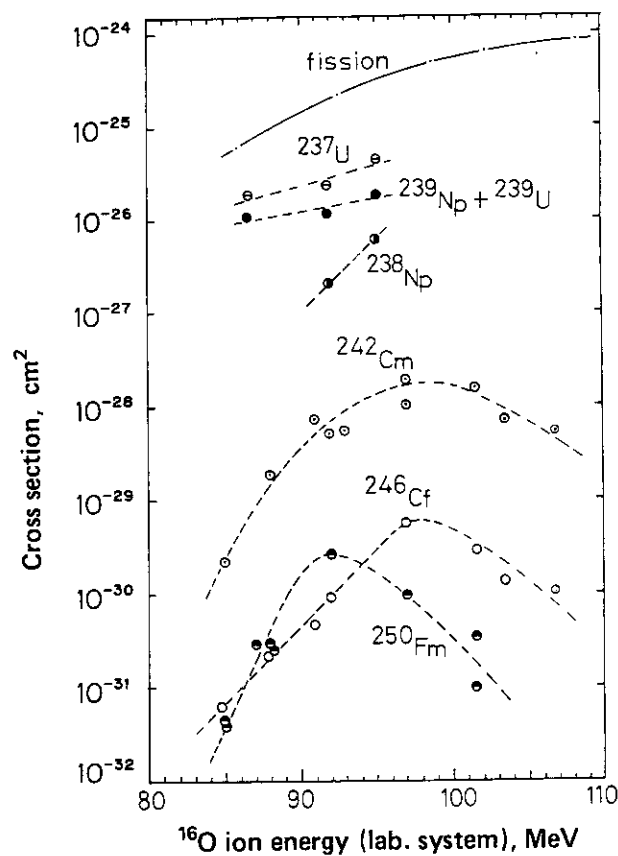

Fig. 6.11 Excitation functions of the $^{16}\text{O} + ^{238}\text{U}$ reaction.
The fission data quoted are from Viola et al. [Vio 62].

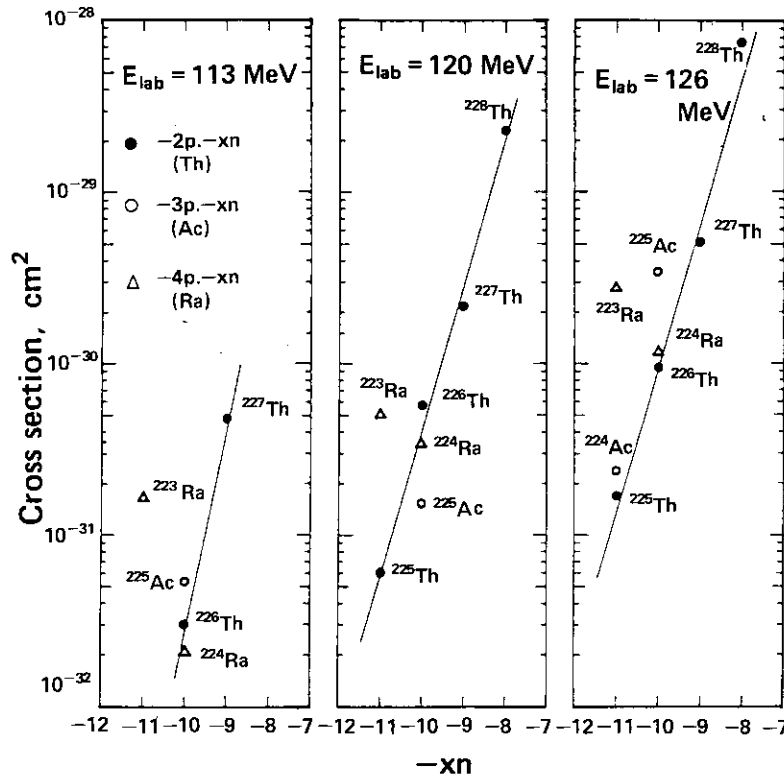

Fig. 6.12 Formation-cross sections of thorium, actinium and radium nuclides synthesized by the $^{16}\text{O} + ^{238}\text{U}$ reaction. The abscissa indicates the number of neutrons picked up and the ordinate shows the measured cross sections.

6.1.2 Transplutonium nuclides synthesized by the $^{12}\text{C} + ^{242}\text{Pu}$ reaction

To investigate the production mechanism of actinide nuclides from heavy-ion bombardment of actinide targets, a systematic study was performed [Shi 85b, Shi 86a, Shi 86b]. The $^{12}\text{C} + ^{242}\text{Pu}$ reaction investigated forms the same compound nucleus of ^{254}Fm by a complete fusion reaction as that formed in the $^{16}\text{O} + ^{238}\text{U}$ reaction.

The ^{242}Pu target of 0.25 mg/cm^2 thickness (99.8% of ^{242}Pu) was prepared by electrodeposition onto an aluminium foil of $7 \mu\text{m}$ thick and was irradiated with about 200 particle nA of ^{12}C ions at the energy of 75–95 MeV. After the irradiation, α -ray spectra of the aluminium-catcher foil were measured. **Figure 6.13** shows a typical α -ray spectrum of an aluminium-catcher foil, in which 7.4, 6.7 and 6 MeV from some α emitters and 4.9 MeV from the ^{242}Pu target were detected. Since it was difficult to identify the transplutonium nuclides by direct α counting of the catcher foil, rapid group-separation was performed using the cation-exchange method (see **Fig. 5.6**). In the irradiation experiment of ^{242}Pu target, only dissolution of the aluminium-catcher foils was sufficient because the target was thin enough for the majority of the product nuclei recoiled out and collected in the catcher foil.

Figure 6.14 shows a typical α -ray spectrum of the transplutonium fraction (conc. HCl solution between the 16th to 20th drops), in which ^{250}Fm , $^{245,246}\text{Cf}$ and $^{238,239,242}\text{Pu}$ (some of the target material which recoiled to the foil) were detected.

Two other techniques, the anion-exchange methods with HCl- CH_3OH (see **Fig. 6.3**) and HNO_3 - CH_3OH media (see **Fig. 3.20**), were also successfully applied to the α -ray spectrometry. The nuclides ^{250}Fm ($T_{1/2}$: 30 min), $^{244,245,246}\text{Cf}$ ($T_{1/2}$: 20 min, 43.6 min, 35.7 h), ^{242}Cm ($T_{1/2}$: 161 d) and ^{242}Am ($T_{1/2}$: 16 h) were identified from the ion-exchange behaviour (see **Figs. 3.19, 3.21** and **4.11**), the half-lives and the radiation energies. An α -ray peak of 5.8 MeV corresponding to the α -ray energy of ^{243}Cm ($T_{1/2}$: 28.5

y, α : 5.785 MeV) and ^{244}Cm ($T_{1/2}$: 18.11 y, α : 5.805 MeV) were detected, but those nuclides were not be identified separately because of their similar α energies and half-lives.

Consequently, the formation-cross sections of such nuclides from the $^{12}\text{C} + ^{242}\text{Pu}$ reaction were obtained and compared with those from the $^{16}\text{O} + ^{238}\text{U}$ reaction [Shi 86a, Shi 86b]. **Figures 6.15, 6.16 and 6.17** show the excitation functions for ^{250}Fm , those for ^{244}Cf , ^{245}Cf and ^{246}Cf , and those for ^{242}Cm (^{242}Am) and $^{243,244}\text{Cm}$, respectively, which were produced by the $^{12}\text{C} + ^{242}\text{Pu}$ (left side) and $^{16}\text{O} + ^{238}\text{U}$ (right side) reactions. The difference between the excitation functions for ^{250}Fm and $^{244-246}\text{Cf}$ produced in the two reactions may be explained mainly by the difference of the Coulomb-barrier energy [Shi 86a].

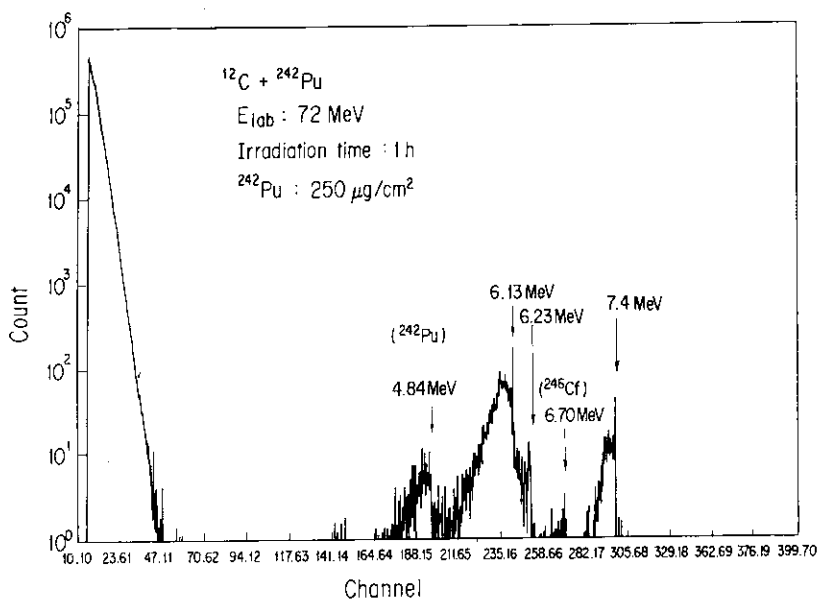

Fig. 6.13 Typical α -ray spectrum of an aluminium-catcher foil which caught the recoil nuclei produced by the $^{12}\text{C} + ^{242}\text{Pu}$ reaction.

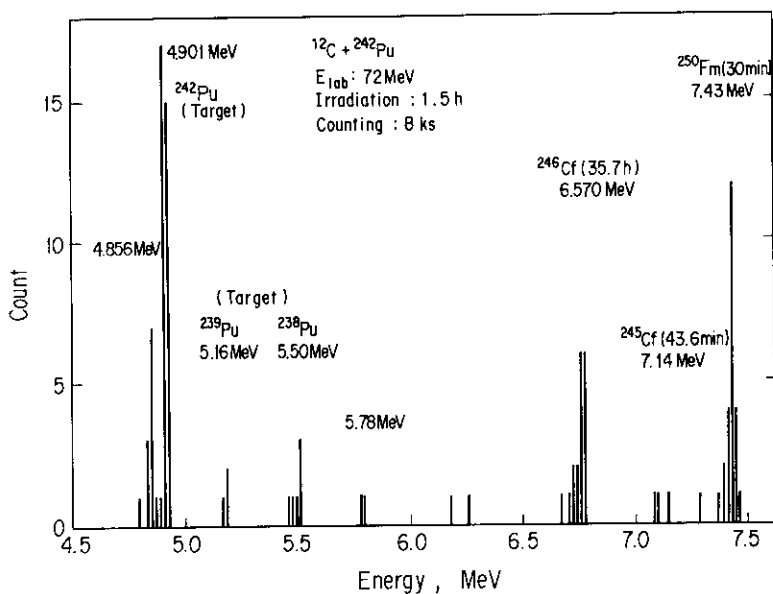

Fig. 6.14 Typical α -ray spectrum of the transplutonium fraction purified by the cation-exchange method.

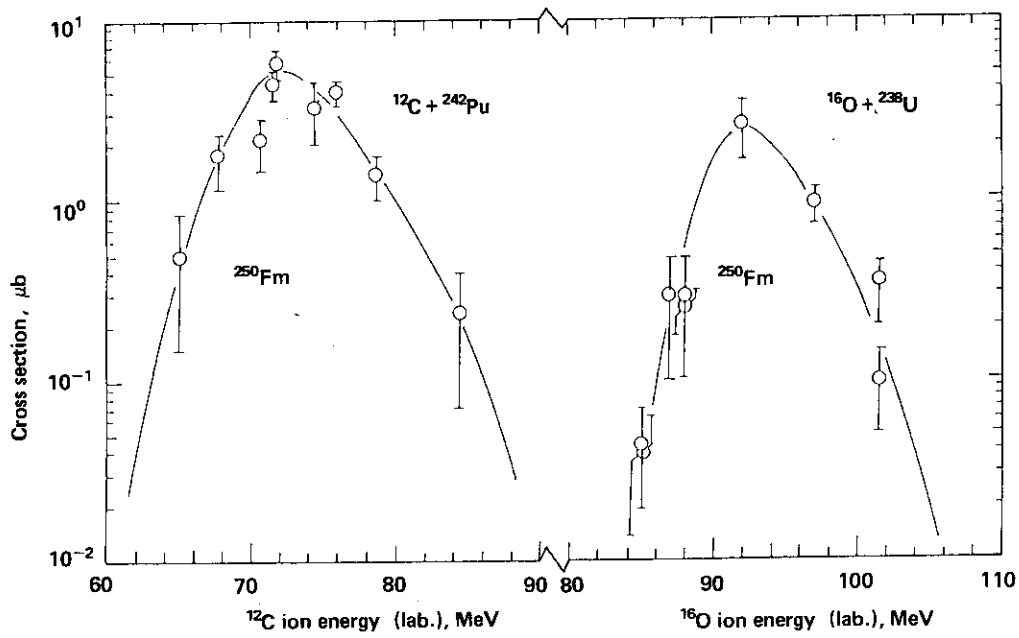

Fig. 6.15 Excitation functions for ^{250}Fm produced by the $^{12}\text{C} + ^{242}\text{Pu}$ (left side) and the $^{16}\text{O} + ^{238}\text{U}$ (right side) reactions.

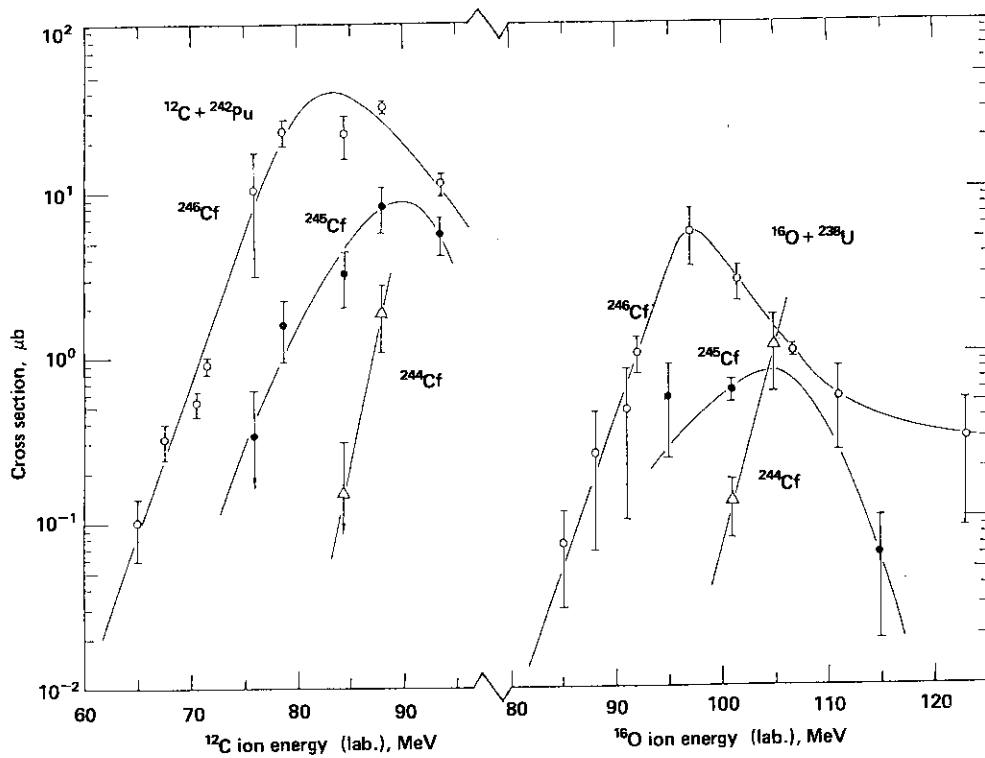

Fig. 6.16 Excitation functions for ^{244}Cf , ^{245}Cf and ^{246}Cf produced by the $^{12}\text{C} + ^{242}\text{Pu}$ (left side) and the $^{16}\text{O} + ^{238}\text{U}$ (right side) reactions.

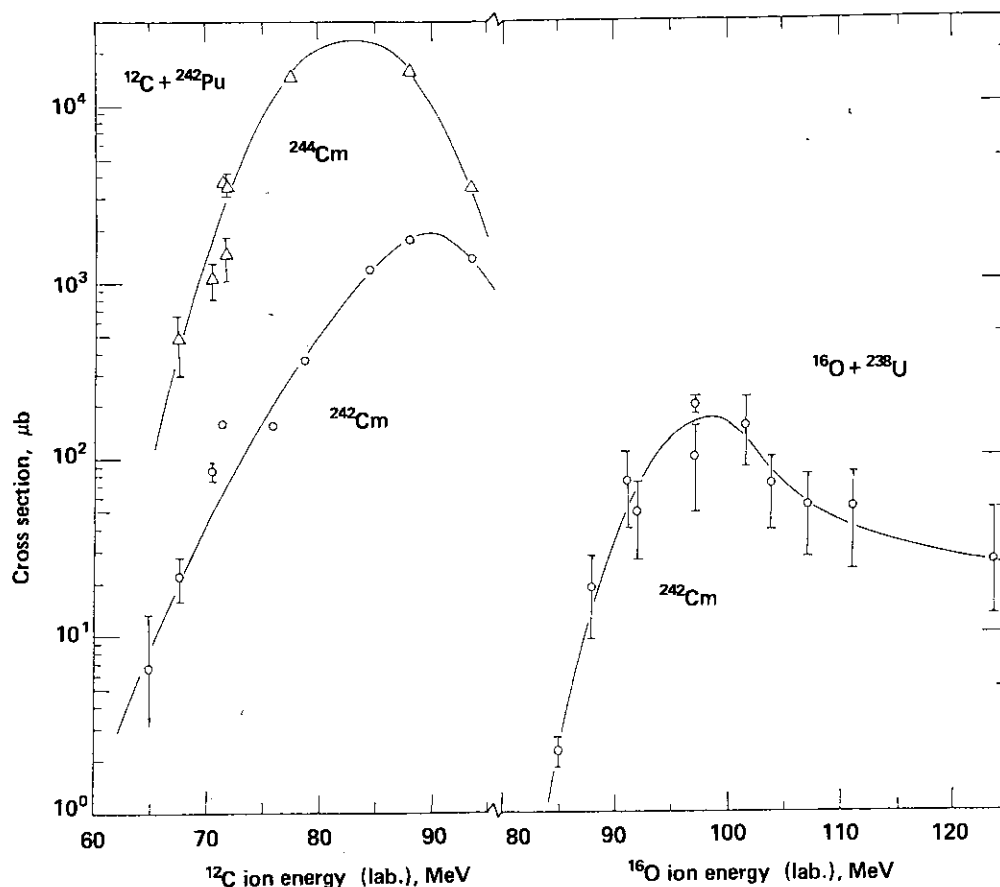

Fig. 6.17 Excitation functions for ^{242}Cm (^{242}Am) and $^{243, 244}\text{Cm}$ produced by the $^{12}\text{C} + ^{242}\text{Pu}$ (left side) and the $^{16}\text{O} + ^{238}\text{U}$ (right side) reactions.

6.2 Decay property of ^{245}Cf

Although ^{245}Cf was synthesized in 1950 as the first isotope of 98th element by bombardment of a microgram target of ^{242}Cm with 35-MeV He ions from a cyclotron [Tho 50], there remains some uncertainty about its decay property. The data on decay characteristics of ^{245}Cf have been reported as follows: the half-life is 43.6 ± 0.8 min [Fie 67]; the decay mode is both orbital electron capture (EC) and α -particle emission (α), and the decay branching is about 70 and 30% for the respective decay modes [Che 56a]; the α -particle energies are 7.137, 7.084, 7.036, 6.983 and 6.886 MeV [Kus 68]. However, the α -ray intensities and data of possible γ rays have not been reported. To study the decay properties in more detail, ^{245}Cf was prepared with the $^{12}\text{C} + ^{238}\text{U}$ reaction [Shi 87a, Mag 86, Mag 87] and was separated using the systems described in Chapters 3, 4 and 5.

Thin uranium targets were used for the determination of formation-cross sections and thick targets were used for the study of the decay property of ^{245}Cf . Thin targets were 99.98% ^{238}U prepared by an electrodeposition method [Oka 86] and had a thickness of 0.7 to 0.9 mgU/cm². Thick targets were prepared from natural uranium by a sedimentation method using acetone [Fji 85] and had a thickness of 3–7 mgU/cm². Irradiation of the thick targets with 90–96 MeV of ^{12}C ions for 1.5–3 h in the JAERI tandem accelerator produced ^{245}Cf . The beam intensity was about 160 particle nA. After rapid separation of Cf by the anion exchange with HCl-CH₃OH media (see Fig. 6.3), the α rays of ^{245}Cf were measured.

Figure 6.18 shows the excitation function for ^{245}Cf in the energy region of 60–90 MeV. The function agreed well with that reported by Sikkeland et al. [Sik 68]. Figure 6.19 shows a typical α -ray spectrum

of the Cf fraction. Five peaks of ^{245}Cf were identified from the energy and half-life, and the relative intensity of each α ray was determined [Shi 87a, Mag 87]. **Figure 6.20** shows the decay curve. The half-life of ^{245}Cf was determined to be 46.4 ± 0.3 min from this curve.

The branching ratio of α/EC was determined from the measurement of the γ ray emitted from ^{245}Bk , the EC-decay-daughter nuclide of ^{245}Cf . It was necessary to remove the initial berkelium nuclides from the direct reaction. After the ^{245}Cf was determined by α -ray spectrometry, the ^{245}Bk formed by the decay of ^{245}Cf was measured. **Figure 6.21** shows a γ -ray spectrum of the Cf fraction which was separated by the anion-exchange method with $\text{HCl}-\text{CH}_3\text{OH}$ mixed media. Californium was separated from the main fission products and other reaction products as well as the target and catcher-foil material, while some $^{95,97}\text{Zr}$ remained. The ^{97}Zr γ ray (254.15 keV) was similar to the γ energy of ^{245}Bk (252.85 keV) and the remaining ^{97}Zr did not allow the detection of ^{245}Bk . Solvent extraction of Bk^{4-} into HDEHP-heptane [Pep 57] was then used to remove Bk, but the removal was not effective because of the low yield. The Cf was finally purified by combined ion-exchange separation. Two different procedures were available. These are shown in **Figs. 6.22** and **6.23**. Either of the procedures was successfully applied. **Figure 6.24** shows a typical γ -ray spectrum of the Cf fraction prepared by procedure-II, measured a few days after the purification. $K_{\alpha 2}$, $K_{\alpha 1}$ and $K_{\beta 1}$ X rays of Cm (104.4, 109.3 and 123.4 keV, respectively) and the Bk γ ray (252.85 keV) were detected.

The branching ratio of α/EC was determined from several experiments to be 0.56 ± 0.04 . The results are summarized and compared, with reference values in **Table 6.1** [Shi 87a, Mag 87].

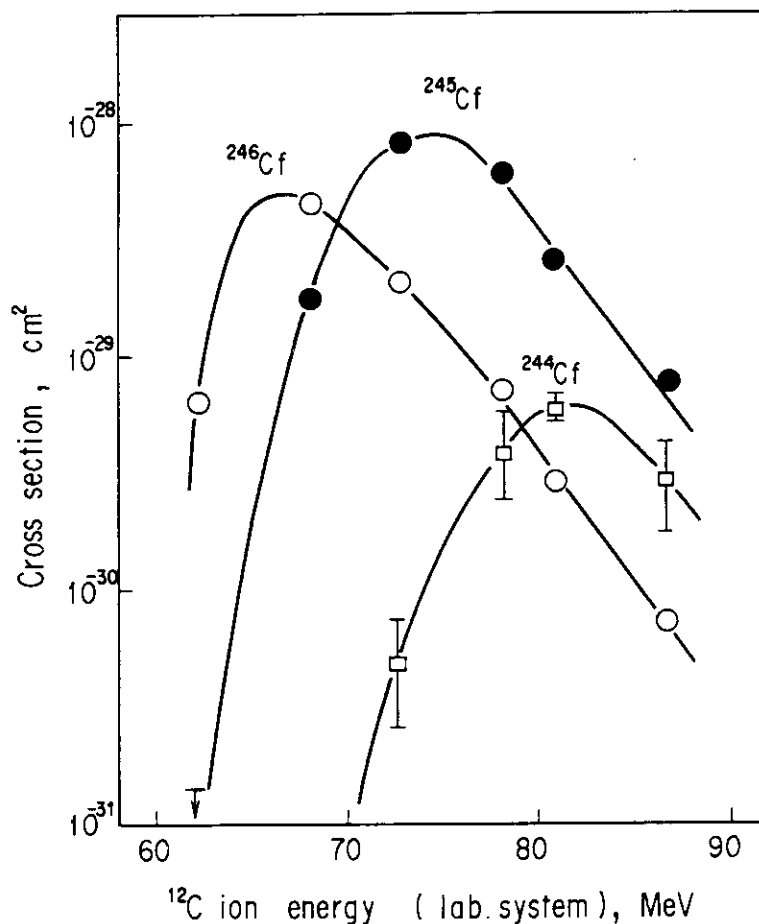

Fig. 6.18 Excitation functions for ^{244}Cf , ^{245}Cf and ^{246}Cf produced by the $^{12}\text{C} + ^{138}\text{U}$ reaction.

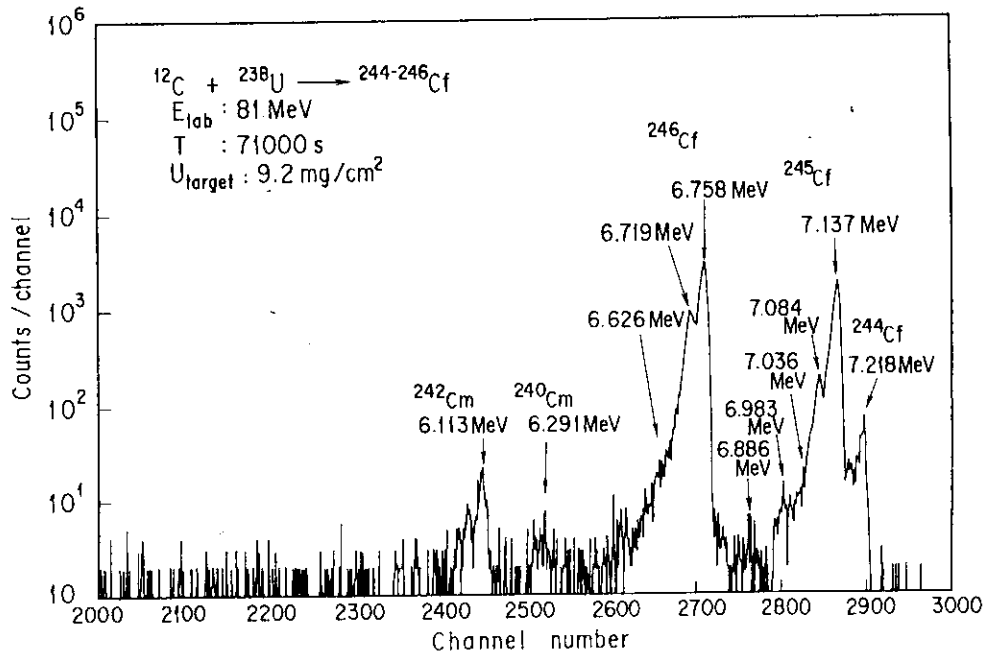

Fig. 6.19 Alpha-ray spectrum of the Cf fraction separated by the anion-exchange method with HCl-CH₃OH media at elevated temperature.

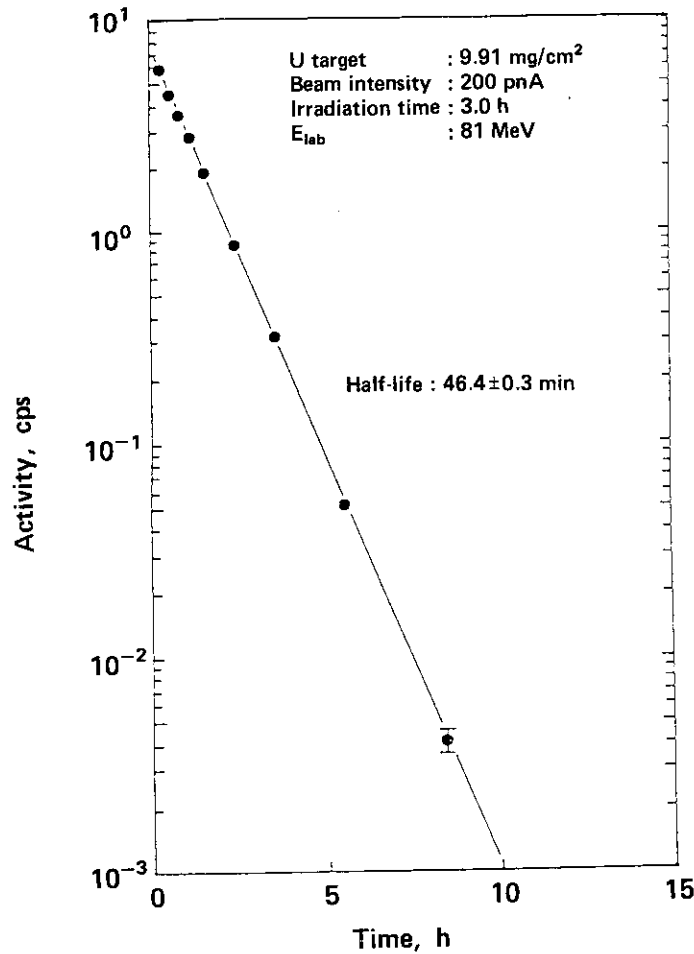

Fig. 6.20 Decay curve of ^{245}Cf .

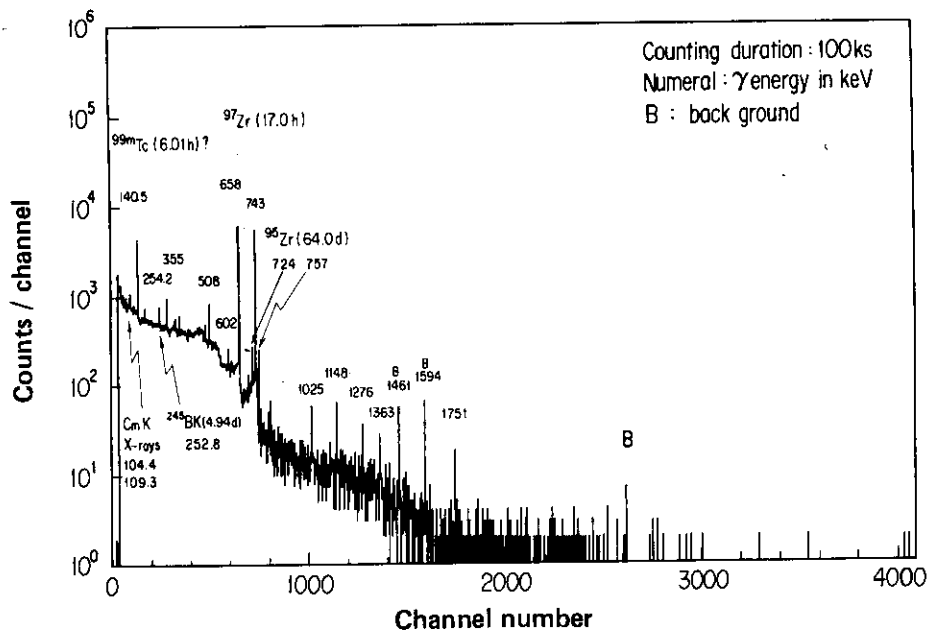

Fig. 6.21 Gamma-ray spectrum of the Cf fraction purified by the anion-exchange method with HCl-CH₃OH media after ²⁴⁵Cf was decayed to ²⁴⁵Bk.

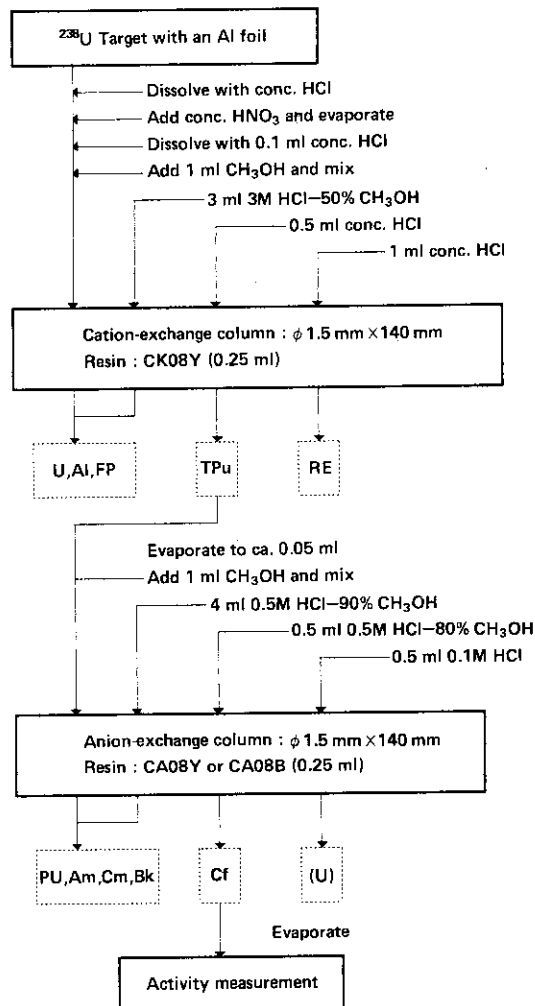

Fig. 6.22 Californium purification procedure-I (for γ -ray spectrometry).

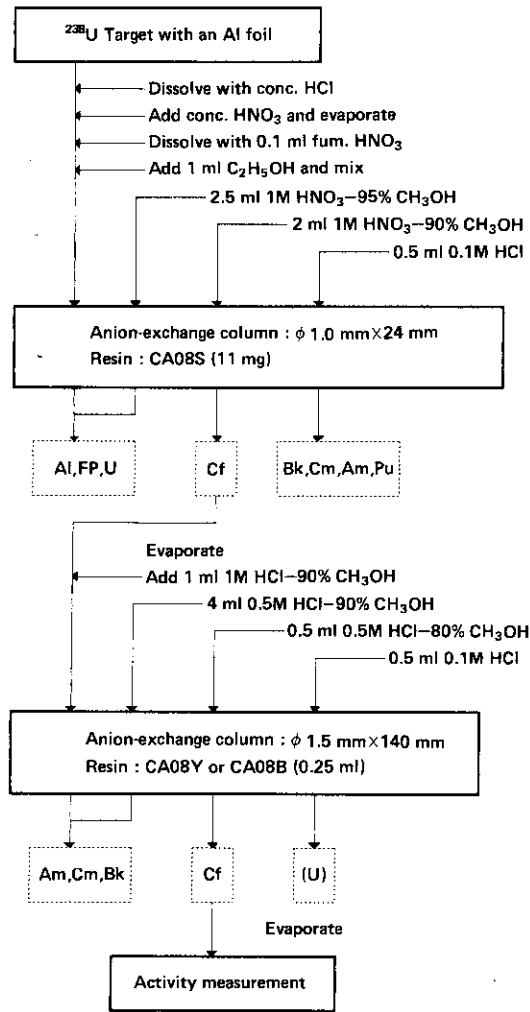

Fig. 6.23 Californium purification procedure-II (for γ -ray spectrometry).

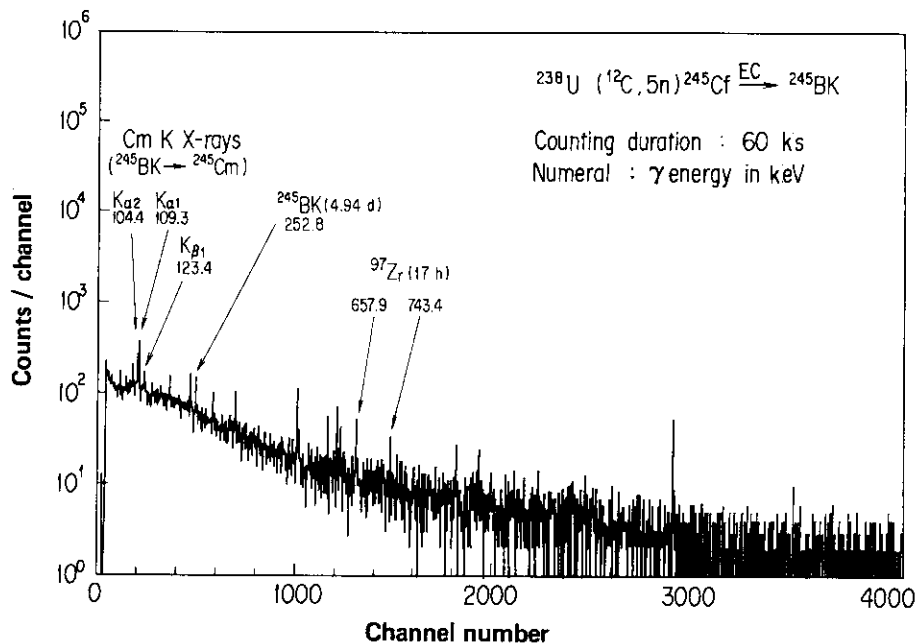

Fig. 6.24 Gamma-ray spectrum of the Cf fraction purified by procedure-II after ^{245}Cf decayed to ^{245}Bk .

Table 6.1 Decay properties of ^{245}Cf .

	This work	References
Half-life	46.3 ± 0.3 min	43.6 ± 0.8 min [Fie 67]
Alpha-ray energy in MeV (relative intensity)	7.137 (100) 7.084 (8.56 ± 0.68) 7.036 (0.49 ± 0.14) 6.983 (0.48 ± 0.15) 6.886 (weak)	7.137 7.084 7.036 [Kus 68] 6.983 6.886
α/EC	0.56 ± 0.04 (α : $36 \pm 2\%$, EC : $64 \pm 2\%$)	0.43 [Che 56a] (α : 30%, EC : 70%)

6.3 Search for new actinide nuclides

It is both fashionable and fascinating for nuclear chemists to search for a new nuclide. Yoshizawa et al. have estimated partial β -decay half-lives of some nuclides [Yos 84]. Many unknown actinide nuclides with half-lives greater than several minutes await to be discovered by the present rapid chemical separation method. Our attention has been directed to the new nuclides ^{241}U , ^{241}Bk , $^{236,237}\text{Am}$ and ^{236}Cm because their identification would be easily done from the parental relation to the well studied daughter nuclides. **Table 6.2** shows some selected actinide nuclides, their predicted nuclear properties and their daughter nuclides.

Table 6.2 Predicted nuclear properties of some selected actinide nuclides.

Nuclide	Half-life [Yos 84]	Decay mode	Daughter nuclide [Led 87]
^{241}U	15 min	β^-	^{241}Np (16.0 min) γ : 135, 175 keV
^{233}Am	6 min	EC α	^{233}Pu (20.9 min) γ : 235, 535 keV ^{239}Np (4.0 min) α : 6.30 MeV α : 6.89 MeV
^{235}Am	15 min	EC	^{235}Pu (25.6 min) γ : 49.3, 756 keV α : 5.83 MeV
^{236}Am	15 min	EC	^{236}Pu (2.85 y) α : 5.768, 5.721 MeV
^{236}Cm	10 min	EC	$^{236}\text{Am} \xrightarrow{\text{EC}} ^{236}\text{Pu}$
^{237}Cm	10 min	EC	^{237}Am (1.22 h) γ : 280, 438 keV α : 6.042 MeV
^{239}Bk	6 min	EC	^{239}Cm (2.9 h) γ : 188 keV
^{241}Bk	15 min	EC	^{241}Cm (32.8 d) γ : 472, 431 keV α : 5.939, 5.885 MeV

i) The search for ^{241}U

A uranium target, bombarded with heavy-ions, was eluted with 0.1 M HCl solution using the anion-exchange separation method with the mixed media of hydrochloric acid and methanol. A large amount of γ -ray impurities were found, however, in the U fraction and a subsequent purification step was required. **Figure 6.25** presents elution curves for the separation of U. The main fission products and Al were eluted with 6 ml of 1 M HCl-90% CH_3OH medium, and the transplutonium elements were eluted with 2.5 ml of concentrated HCl solution. For further purification of the U fraction, U and Np+Pa were

chromatographically eluted with 20 ml of 0.1 M HCl-70% CH₃OH mixed medium.

The nuclides $^{237,239}\text{U}$ ($T_{1/2}$: 6.75 d, 23.5 min) and $^{238,239}\text{Np}$ ($T_{1/2}$: 2.117 d, 2.344 d) formed by the $^{16}\text{O} + ^{238}\text{U}$ reaction were detected in the respective fractions by γ -ray spectrometry. Particular attention was devoted to the search for the new isotope ^{241}U , but no γ rays emitted from ^{240}U ($T_{1/2}$: 14.1 h, γ : 554.6 and 597.4 keV) [Hse 81] nor those ascribable to ^{241}U was observed. This consequence was understandable since the formation-cross section of $^{240,241}\text{U}$ in the reaction would be extremely small.

ii) The search for neutron-deficient nuclides of Am and Cm

An attempt was made to synthesize $^{238,239,240,242}\text{Cm}$ ($T_{1/2}$: 2.3 h, 2.9 h, 27 d, 161 d) [Led 78, Usu 81] and $^{238,239}\text{Am}$ ($T_{1/2}$: 1.63 h, 11.9 h) [Led 78] by the bombardment of ^{235}U (2.0-2.5 mg/cm²) with ^{12}C ions (80-90 MeV) for 3 h. But no γ rays attributable to new neutron-deficient nuclides of Am and Cm were detected, even though the fraction itself was chemically pure and no disturbing γ rays were present. **Figure 6.26** shows the purification procedures used for Am and Cm prior to the γ -ray measurement.

The use of a ^{233}U target would have been preferable to synthesize the new isotopes of Am and Cm having half-lives of 10-15 min, listed in **Table 6.2**. **Figure 6.27** shows the excitation functions [Shi 87c] of $^{235-239}\text{Cm}$ and $^{238-242}\text{Cf}$ from the $^{12}\text{C} + ^{233}\text{U}$ reaction calculated with the ALICE code [Bla 75, Bla 76].

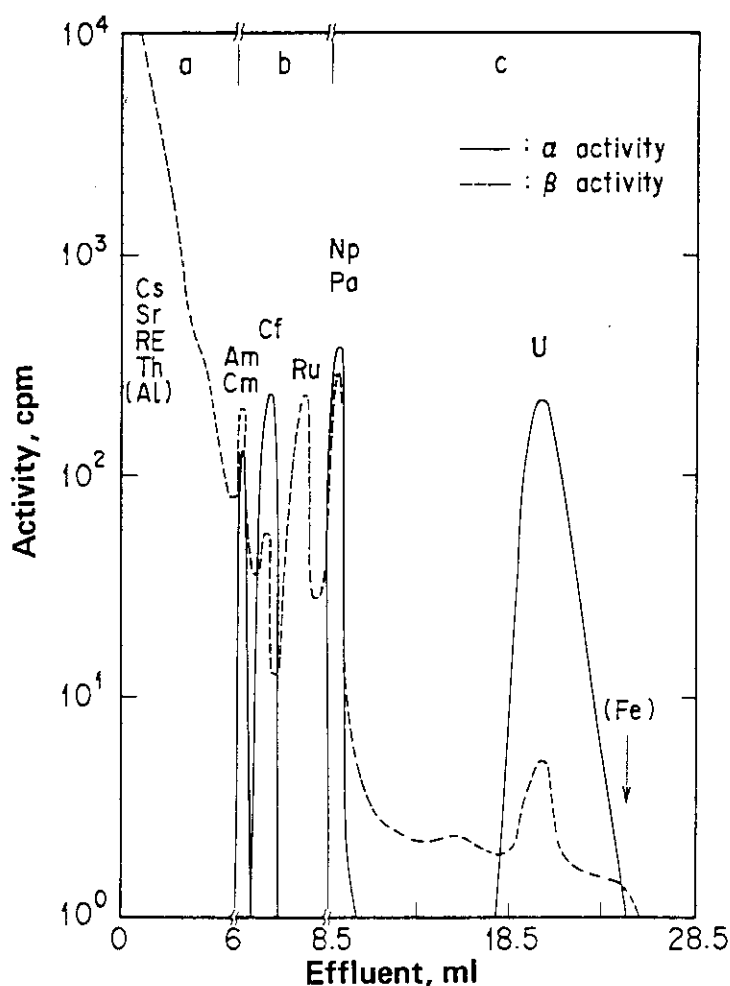

Fig. 6.25 Anion-exchange separation of Np and U from Al, fission products and transplutonium elements with hydrochloric acid and methanol solutions at 90°C. Resin: CA 08Y (0.25 ml), sample solution: 0.05 ml conc. HCl-0.5 ml CH₃OH, a: 1 M HCl-90% CH₃OH 6 ml, b: conc. HCl 2.5 ml, c: 0.1 M HCl-70% CH₃OH 20 ml.

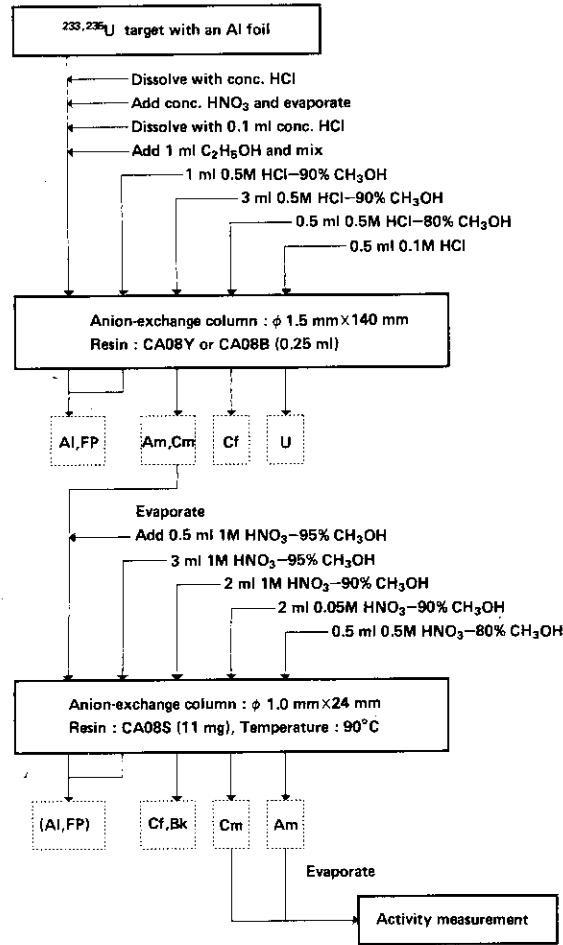

Fig. 6.26 Purification procedures for Am and Cm.

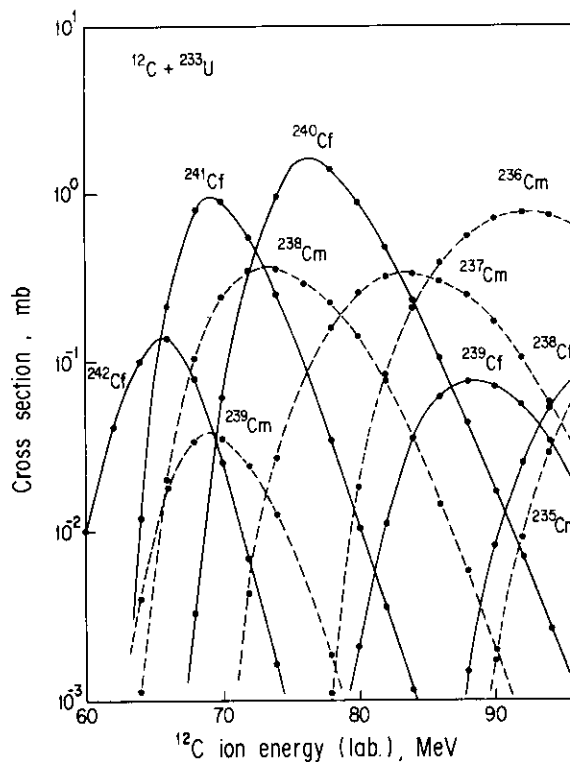

Fig. 6.27 Excitation functions for $^{238-242}\text{Cf}$ and $^{235-239}\text{Cm}$ in the $^{12}\text{C} + ^{233}\text{U}$ reaction calculated with the code ALICE.

iii) The search for neutron-deficient Bk isotopes

The nuclides ^{242}Bk ($T_{1/2}: 7.0 \pm 1.3$ min) [Wil 79] and $^{243,244}\text{Bk}$ ($T_{1/2}: 4.5 \pm 0.3$ h, 4.35 ± 0.15 h) [Hul 53, Che 56b, Ahm 66] were synthesized by bombardment of ^{241}Am targets with 35- and 28-MeV ^4He ions, respectively. These nuclides were identified from their half-lives, radiation energies and chemical behaviour [Usu 86, Sue 86].

Because of the short half-life of ^{242}Bk , the recoil products of nuclear reactions were transferred by the gas-jet-recoil-transportation system (refer to Section 6.5) and were trapped on a Teflon-catcher foil. After washing out and dissolving the recoil products, Bk was separated by the anion-exchange method using the mixed media of hydrochloric acid and methanol, described in Section 4.6.2. The anion-exchange separation of Bk and the source preparation were rapidly accomplished within a few minutes.

Bombardment with the 42-MeV beam would give better results for ^{241}Bk search. Figure 6.28 shows the excitation functions for $^{239-245}\text{Bk}$ from the $^{241}\text{Am} + ^4\text{He}$ reaction calculated by the ALICE code [Yos 87].

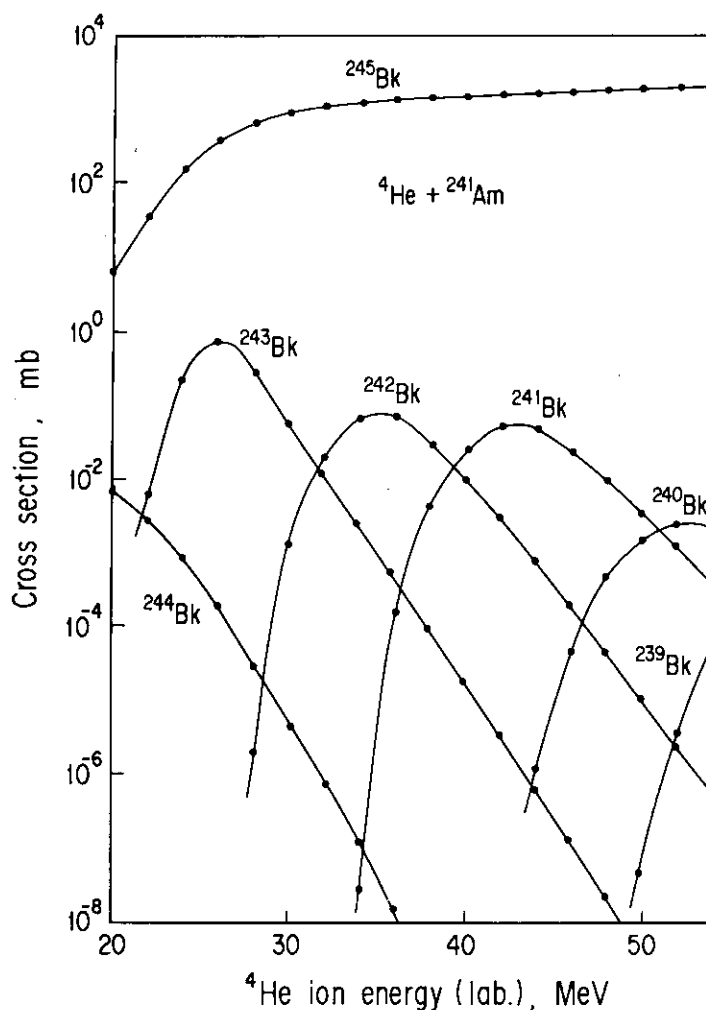

Fig. 6.28 Excitation functions for $^{239-245}\text{Bk}$ in the $^4\text{He} + ^{241}\text{Am}$ reaction calculated with the code ALICE.

6.4 Burn-up determination of spent nuclear fuels

A stable isotope, ^{148}Nd , and the total amount of Nd isotopes are excellent fission monitors of ^{235}U and ^{239}Pu . After chemical purification, the Nd isotopes are determined by the IDM method (isotope-dilution-mass spectrometry) as a standard method of burn-up measurement [Reg 77, Mak 83, AST 85]. The total amount of Nd isotopes may be determined by an elemental analysis such as ICP emission spectroanalysis. The radioactive isotope, ^{147}Nd ($T_{1/2}$: 10.98 d), can also be used as a fission monitor to test fuels of short irradiation [Yan 86]. Quantitative separation of Nd is necessary in such a case.

Measurements of the main transplutonium nuclides ($^{241-243}\text{Am}$ and $^{242-244}\text{Cm}$) in spent nuclear fuel are required for evaluation of accurate burn-up and the amounts of α waste [Bon 75], and for studying isotope correlations among them [Ume 73, Suz 86]. The transplutonium nuclides have also been determined by α -activity measurements and mass spectrometry.

Natsume and his co-workers have determined radiochemically the heavy elements (U, Np, Pu, Am and Cm) and some selected fission products (Cs, Mo and Nd) for burn-up measurement by sequential ion-exchange separation [Nat 71, Nat 72, Ume 74, Nat 77, Suz 86, Usu 88d, Shi 88]. This method requires several ion-exchange steps to purify Am, Cm and Nd. The process takes several weeks. In the ASTM method [AST 85], U and Pu are separated from the main fission products by anion exchange with nitric acid solutions, and Nd is finally purified from Am and Cm by repeating the anion exchange with nitric acid-methanol mixed media at ambient temperature. However, Nd is not separated quantitatively.

By applying the anion-exchange-separation method described in Chapter 3, three separation procedures for Nd and the transplutonium elements in spent nuclear fuel have been developed [Usu 88b]. These are described in the following three sections.

6.4.1 Separation of Nd for IDM determination

A mixture of spent fuel specimens (burn-up: 20–30 GWd/t) and fission products containing ^{147}Nd was used as samples. After a reduction-oxidation treatment to convert the oxidation state of Pu to Pu(IV), the residue was redissolved in a small amount of concentrated HNO_3 solution. The resulting solution was mixed with a 10-fold volume of $\text{C}_2\text{H}_5\text{OH}$. An appropriate portion of this solution, containing less than about 5 mg of U, was transferred to a conventional glass column, ϕ 4 mm \times 8 cm long (1 ml), packed with anion-exchange resin, BIORAD AG 1 X4. If sequential separation of U and Pu is necessary, the preliminary group-separation of FP, U and Pu would be performed by anion exchange with HCl solutions [Nat 72].

Figure 6.29 shows the elution curves for the Nd separation for the IDM determination by a conventional column at ambient temperature and pressure. After passing the sample solution through the column, the inner wall of the column was rinsed with 2–5 ml of 1 M HNO_3 –90% CH_3OH and $^{134,137}\text{Cs}$ was immediately eluted from the column. The isotopes ^{90}Sr , ^{90}Y and U(VI) were eluted from the column with 50 ml of 1 M HNO_3 –90% CH_3OH medium. Then, ^{154}Eu , ^{244}Cm , $^{241}\text{Am} + ^{147}\text{Pm}$, ^{147}Nd and ^{144}Ce were eluted in that order with 0.5 M HNO_3 –80% CH_3OH medium. The effluent from 5 ml to 25 ml was taken as the Am + Cm fraction.

Neodymium was recovered in the next 30 ml of effluent with considerable yield, being monitored by the γ activity of the ^{147}Nd . If ^{147}Nd was not present, the elution position of Nd had been predicted by monitoring the α activity of ^{241}Am or the β activity of ^{147}Pm . Although the Nd fraction overlapped with the Pm + Am fraction by 5–10% and with some other nuclides such as ^{95}Zr and $^{103,106}\text{Ru}$, the separation of Nd from Ce and Sm, which disturbed the IDM determination of Nd, was complete. After the Nd elution, Pr, Ce and Pu(IV) were washed out of the column with 0.1 M HCl (or 0.1 M HNO_3) solution.

On the basis of the above results, the steps of Procedure I for the IDM determination Nd are given in **Fig. 6.30**. Neodymium and Am + Cm samples were prepared by evaporating the fractions for the IDM measurement and α -ray spectrometry.

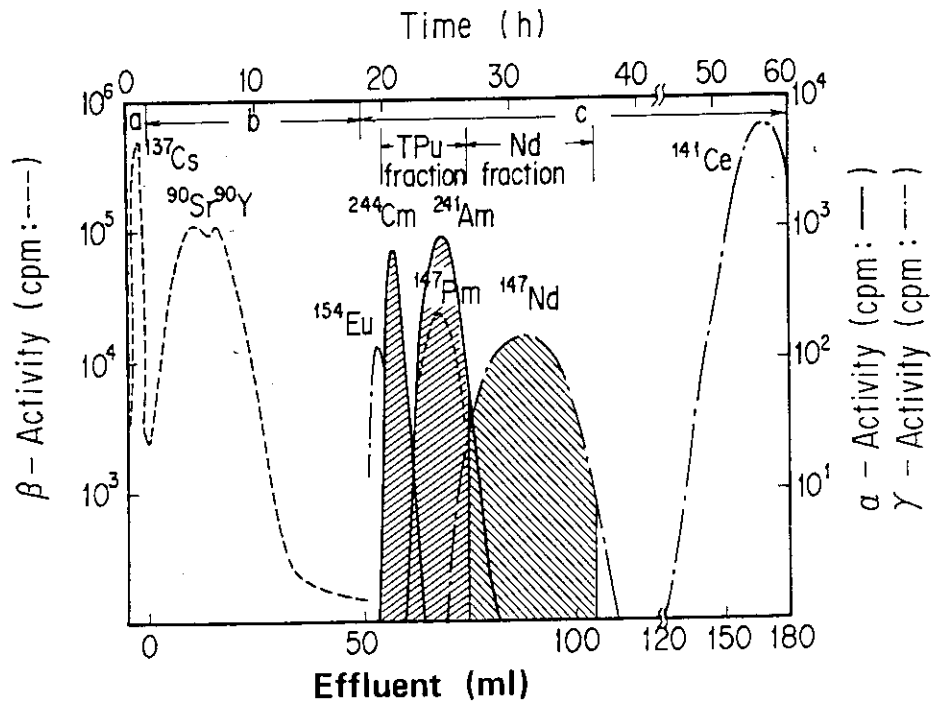

Fig. 6.29 Separation of Nd, Am and Cm on conventional anion-exchange resin at ambient temperature and pressure. Resin: BIORAD AG 1×4 (−400 mesh) 1 ml, column bed: ϕ 4 mm×8 cm, a: sample solution (0.3 ml conc. HNO_3 +3 ml $\text{C}_2\text{H}_5\text{OH}$) and wash solution (2 ml 1 M HNO_3 −90% CH_3OH), b: 50 ml 1 M HNO_3 −90% CH_3OH , c: 130 ml 0.5 M HNO_3 −80% CH_3OH , flow rate: ca. 0.4 cm/min.

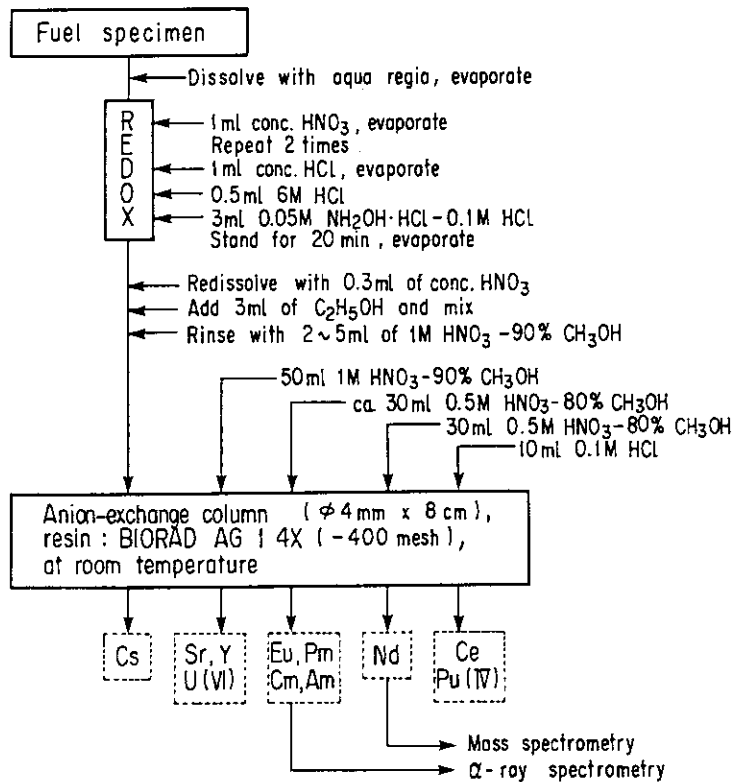

Fig. 6.30 Procedure I (separation of Nd for IDM determination).

This procedure is so useful for analysis of burn-up measurements that it has already been applied routinely. **Figure 6.31** shows typical elution curves for a 40-GWd/t spent fuel specimen from a commercial light water reactor with about 5-y cooling time. Of course, the ^{147}Nd had decayed out, but the Nd fraction was successfully prepared for the IDM determination. Since U and Pu were recovered in the Sr and Ce fractions, respectively, it is possible to take U and Pu for the IDM without further separation of U and Pu. It took about 3 d to separate the Nd, but the procedure was simple enough to allow analyses of a number of samples in parallel.

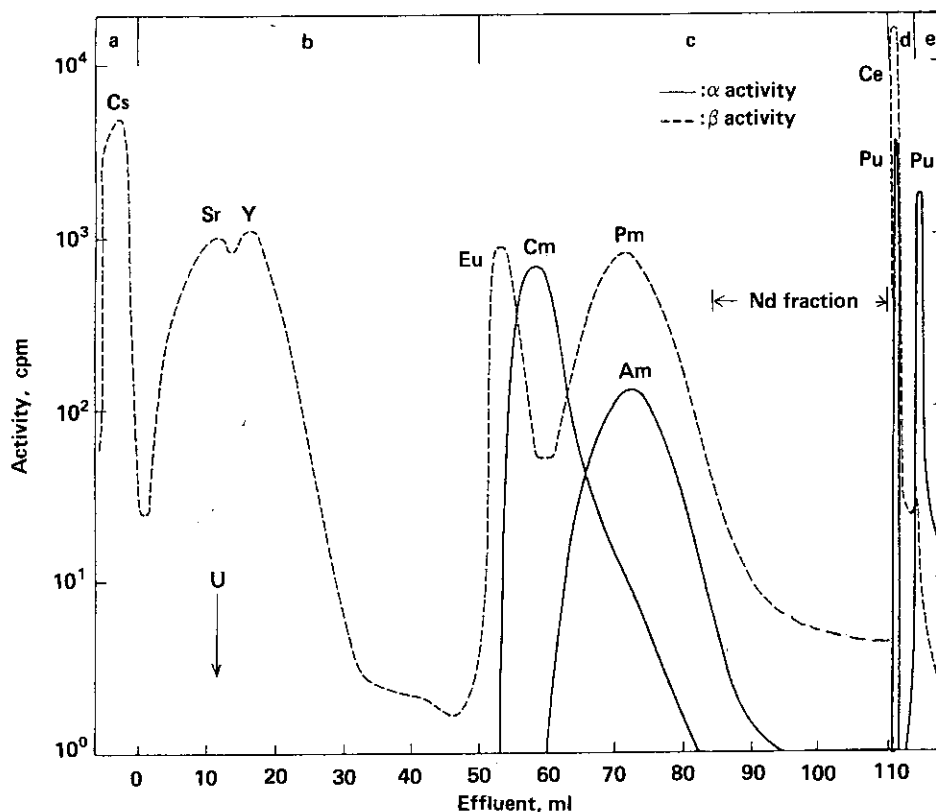

Fig. 6.31 Typical elution curves for separation of a 40 GWd/t burn-up spent fuel specimen based on Procedure I. Resin: BIORAD AG 1×4 (−400 mesh) 1 ml, column bed: ϕ 4 mm×8 cm, a: sample solution (0.3 ml conc. HNO_3 +3 ml $\text{C}_2\text{H}_5\text{OH}$) and wash solution (2 ml 1 M HNO_3 −90% CH_3OH), b: 50 ml 1 M HNO_3 −90% CH_3OH , c: 60 ml 0.5 M HNO_3 −80% CH_3OH , d: 4 ml 10 M HCl, e: 4 ml 0.1 M HCl, flow rate: 0.5–1 cm/min, at room temperature.

6.4.2 Quantitative separation of Nd, Am and Cm

Figure 6.32 shows chromatograms for quantitative separation of the rare-earth and transplutonium elements using a fine resin, MCI CA06Y, at ambient temperature and pressure. The resin was packed in a glass column, ϕ 4 mm × 4 cm long (0.5 ml). It was necessary to transport the entire sample with a minimum amount of 1 M HNO_3 −90% CH_3OH to the column. The flow rate was so slow (ca. 0.09 cm/min) that the ion exchanges always attained equilibrium and the relevant elements were separated effectively. Cesium, Te, Sr, Y, Np, U(VI) and Eu were eluted from the column with the first 4 ml of 0.5 M HNO_3 −80% CH_3OH eluent; Cm and Ba were eluted next with 4 ml of the eluent (Cm fraction); and Am + Pm were eluted with the succeeding 8 ml of the eluent (Am fraction). Alpha-ray spectrometry of the Am and Cm fractions enabled the quantitative determination of those α -emitting nuclides.

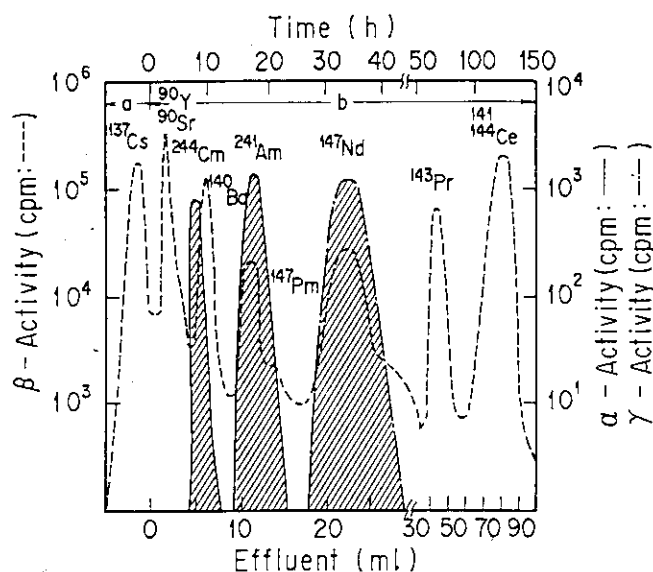

Fig. 6.32 Quantitative separation of Nd, Am and Cm on fine anion-exchange resin at ambient temperature and pressure. Resin: CAO8Y(0.5 ml), column bed: ϕ 4 mm \times 4 cm, a: sample solution(0.1 ml conc. $\text{HNO}_3 + 0.9$ ml $\text{C}_2\text{H}_5\text{OH}$), b: 100 ml 0.5M HNO_3 -80% CH_3OH , flow rate: ca. 0.09 cm/min.

After elution of Am + Pm, Nd was eluted with the next 14 ml of the same eluent. **Figure 6.33** shows γ -ray spectrum of the Nd fraction. Radioactivity of the neighbouring rare-earth elements was not detected in the Nd fraction, although a little contamination from the activity of ^{95}Zr , $^{103,106}\text{Ru}$ and ^{140}La was present. The ^{140}La contamination occurred between the elution positions of Ba and La, since the decay of ^{140}Ba fed its daughter, ^{140}La , continuously. More than 99.9% of the ^{147}Nd activity was recovered in the Nd fraction.

Further elution with the same eluent effectively separated Pr and Ce. In addition to ^{147}Nd and $^{141,144}\text{Ce}$, identified by γ -ray spectrum analysis, ^{143}Pr was detected by β -activity measurements. Plutonium (IV) absorbed on the resin column was eluted with 0.1 M HCl solution.

Table 6.3 summarizes the separation factors of the rare-earth and transplutonium elements relative to Nd and compares these with those in the literature [Far 62, Kor 63]. The separation factors at room temperature agreed well with the reported data. Separation factors between two elements at room temperature were larger than those at elevated temperature [Usu 87c, Usu 87g].

This procedure, shown in **Fig. 6.34** as Procedure II, enabled the quantitative separation of Nd, Am and Cm from irradiated U samples. Although it took about 2 d to isolate the Nd, the total amount of the Nd isotopes would be determined.

Table 6.3 Separation factors relative to Nd.

Eluent	Y	Eu	Cm	Pm	Am	Nd	Pr	Ce	La	Temperature	Reference
0.5 M HNO_3 - 80% CH_3OH	0.07	0.16	0.23	0.49	0.52	1	1.94	3.44	5.4	ambient temp.	[Usu 88b]
0.5 M HNO_3 80% CH_3OH	0.1	0.28	0.40	0.66	0.71	1	1.56	2.23	3.0	90°C	[Usu 87g]
0.01 M HNO_3 - 90% CH_3OH	0.1	0.25	0.38	0.60	0.70	1	1.62	2.55	3.7	90°C	[Usu 87g]
10% 1 M HNO_3 + 90% CH_3OH	0.03	0.09	—	(0.38)	—	1	2.2	3.72	6.5	ambient temp.	[Far 62]
10% 5 M HNO_3 + 90% CH_3OH	0.02	0.12	—	—	—	1	1.84	2.72	—	ambient temp.	[Kor 63]

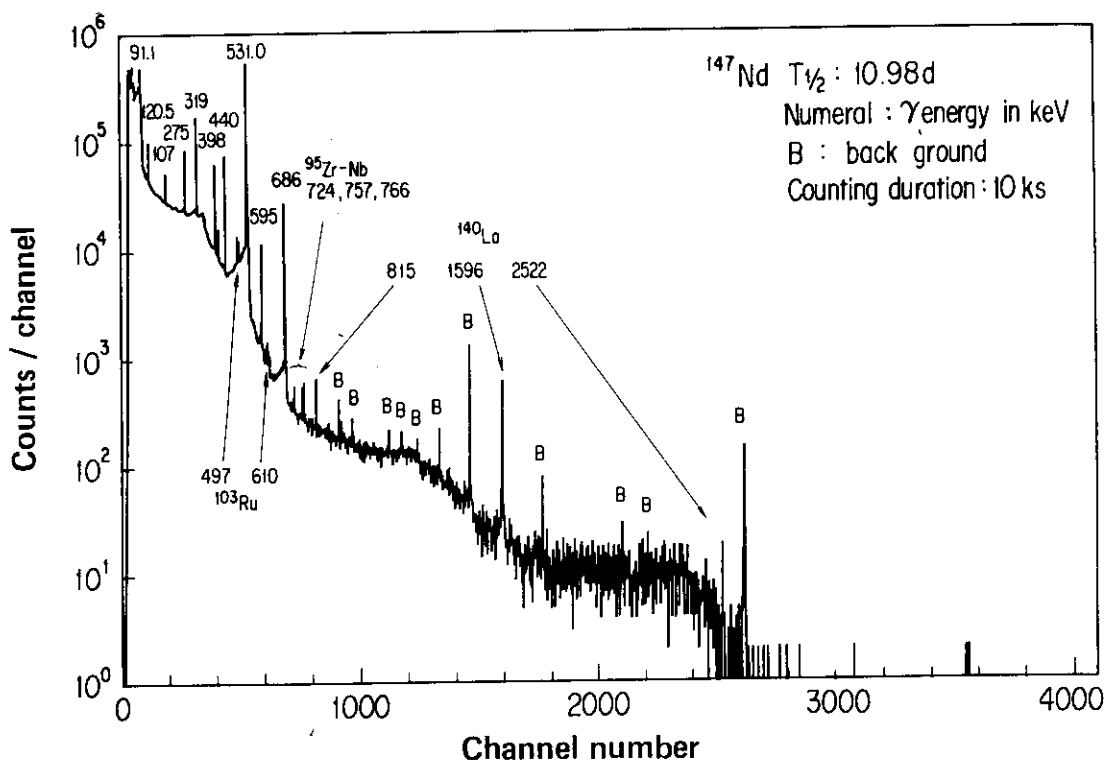

Fig. 6.33 Gamma-ray spectrum of ¹⁴⁷Nd in the Nd fraction.

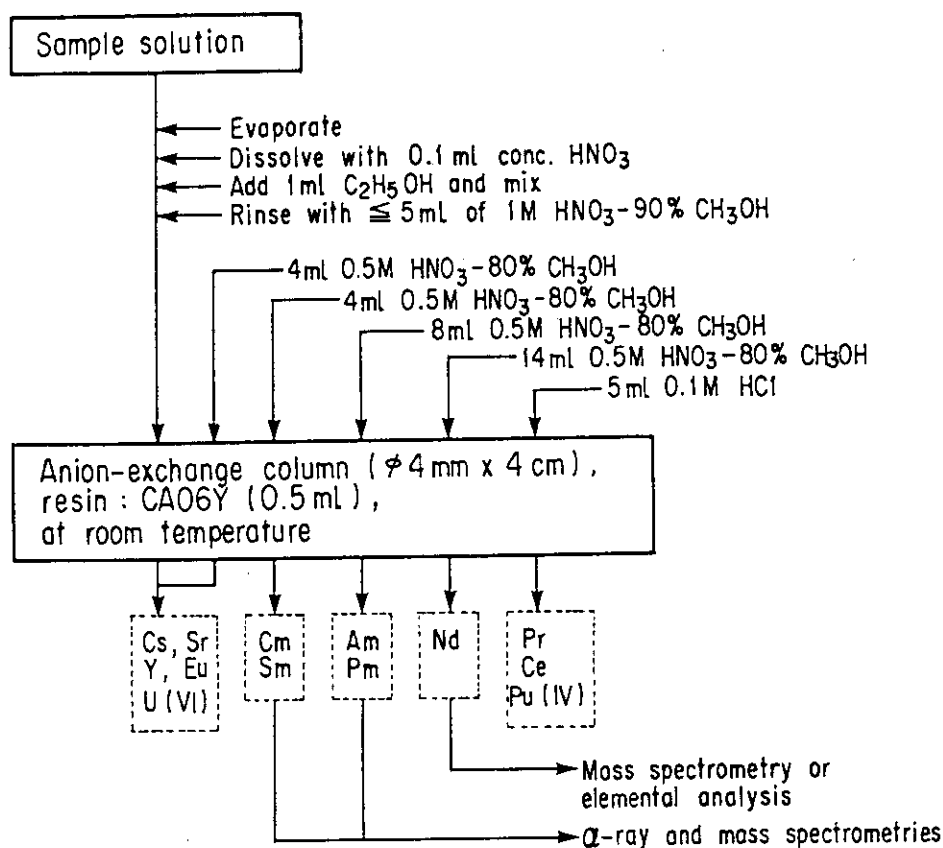

Fig. 6.34 Procedure II (quantitative separation of Nd, Am and Cm in spent nuclear fuels).

6.4.3 Rapid separation of Nd, U, Pu, Am and Cm

The rapid separation of light lanthanoids, including Nd, and transplutonium elements has been described in Chapter 3. In this section, sequential rapid separation will be examined. Anion-exchange separation of U and Pu from main fission products with HNO_3 solutions at ambient temperature and elevated pressure is first performed. This is followed by anion-exchange separation of Nd, Am and Cm from the fission products using nitric acid-methanol mixed media at elevated temperature and pressure.

Figure 6.35 shows elution curves for the initial anion-exchange separation of the irradiated U with concentrated HNO_3 solution using a 0.25-ml column of MCI GEL CA08B resin at ambient pressure and elevated pressure. After 0.2 ml of sample solution was charged, Nd, Am, Cm and other main fission products were passed through the column within the first 0.3 ml of concentrated HNO_3 solution (FP fraction) and then U was eluted in the next 0.5 ml of the same solution. Plutonium was recovered with 0.1 M HCl (or 0.1 M HNO_3) solution.

The FP fraction was concentrated to about 0.05 ml, and 0.5 ml of $\text{C}_2\text{H}_5\text{OH}$ was added to the solution. The mixture was transferred to a small column (ϕ 1 mm \times 5.7 cm) packed with 0.05 ml of CA08S. **Figure 6.36** shows the elution curves for the rapid separation of Nd, Am and Cm at 90°C . Cesium, Te, Sr, Y, Ba and Eu were washed out with the first 0.6 ml of 0.01 M HNO_3 -90% CH_3OH eluent. Next, the Cm(+Sm), Am+Pm and Nd were developed chromatographically with 2 ml of the eluent. Cross contaminations in appropriate fractionations were within 1%.

The entire rapid separation procedures are given in **Fig. 6.37** as Procedure III. The time required to separate Nd was less than 1 h. The procedures are quite adequate for an automated operation. If the separation of Nd from a milligram amount of irradiated U is necessary in a one-column operation, the column volume should be 0.25 ml [Usu 87g].

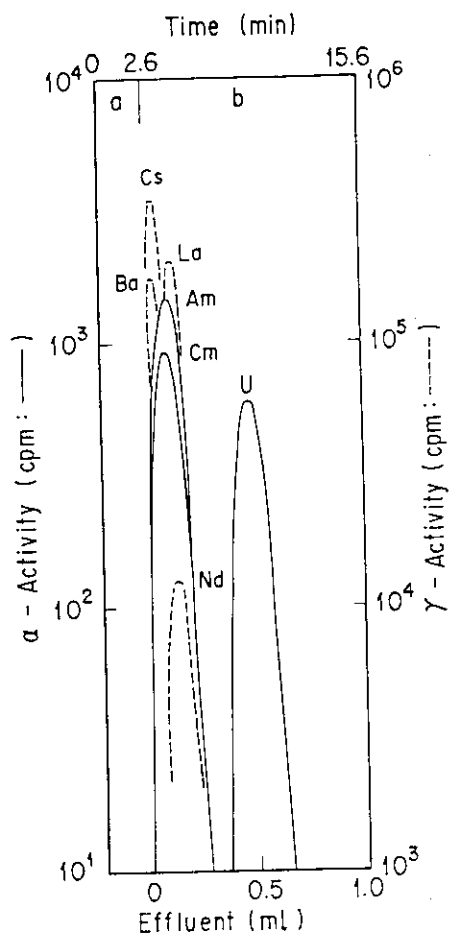

Fig. 6.35 Rapid initial-separation of irradiated U with anion exchange in HNO_3 solution at ambient temperature and elevated pressure. Resin: CA08B (0.25 ml), column bed: ϕ 1.5 mm \times 14 cm, a: sample solution (0.2 ml concentrated HNO_3), b: 1 ml concentrated HNO_3 , flow rate: ca. 4.4 cm/min.

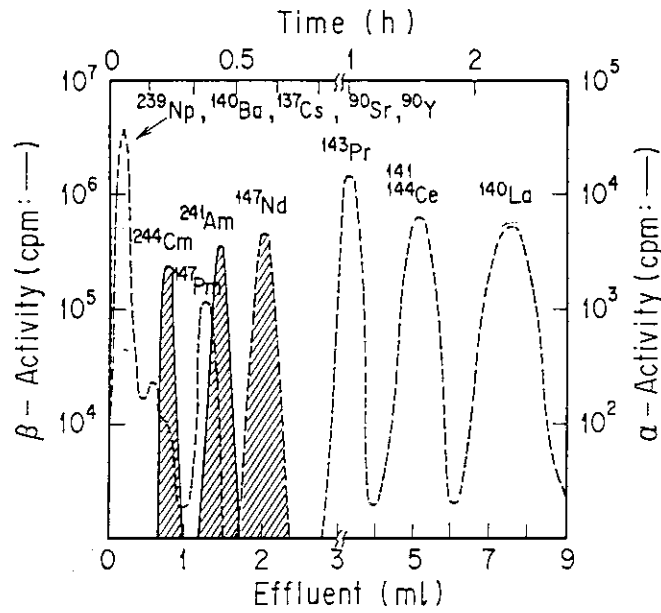

Fig. 6.36 Rapid separation of Nd, Am and Cm with anion exchange in $\text{HNO}_3\text{-CH}_3\text{OH}$ medium at 90°C . Resin: CA08S (23.6 mg), column bed. ϕ 1 mm \times 5.7 cm, sample solution: 0.05 ml concentrated $\text{HNO}_3 + 0.5$ ml $\text{C}_2\text{H}_5\text{OH}$, eluent: 9 ml 0.01 M $\text{HNO}_3\text{-90\% CH}_3\text{OH}$, flow rate: ca. 7 cm/min.

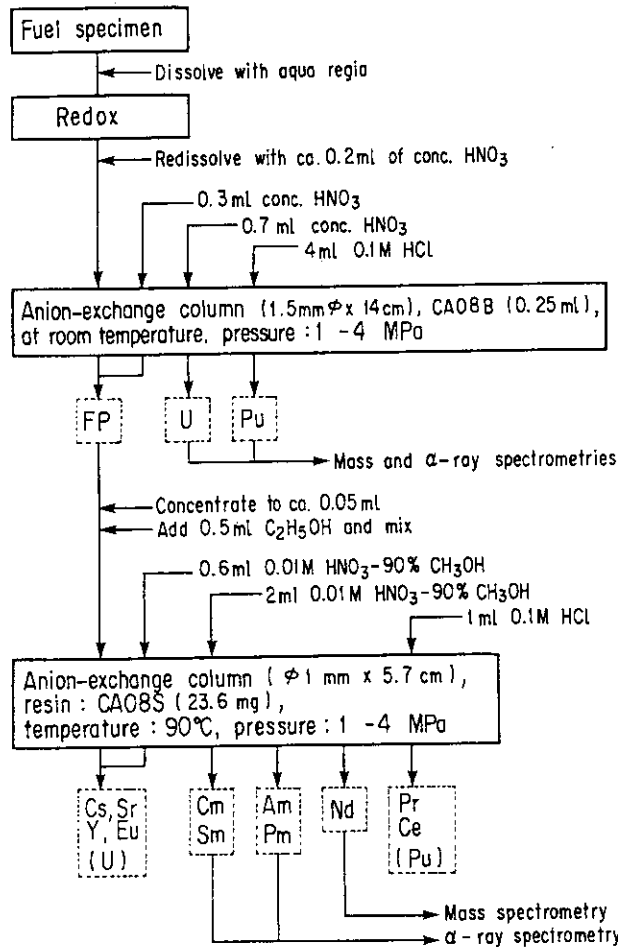

Fig. 6.37 Procedure III (rapid separation of Nd, U, Pu, Am and Cm in spent nuclear fuels).

6.5 System design for on-line rapid ion-exchange separation

The separation of transplutonium elements formed in the actinide targets bombarded with heavy-ions in the JAERI tandem accelerator has been done only as off-line experiments. It required at least 10 min from the end of irradiation to the start of the chemical procedures, due to the cooling of very short-lived radioactivity and the manual transportation of the target and catcher foils. To shorten the time, an on-line chemical separation system should be introduced for the investigation of short-lived transplutonium nuclides. The author has designed an on-line rapid ion-exchange system which utilize one or two of ion-exchange separations developed in this report [Usu 86].

Figure 6.38 shows a block diagram of the on-line rapid ion-exchange-separation system. The recoil nuclei synthesized by heavy-ion reactions can be transferred to the separation system within one second with 60–90% yield by a gas-jet transportation system attached to the beam line [Shi 87b]. The nuclei trapped in a 6-way valve are dissolved in a loading solution and transferred to a column by controlled nitrogen-gas pressure or with a high pressure pump. Eight kinds of solutions can be successively supplied to the column. A fixed volume of eluent can be fed to the column and the effluent is introduced to a radioactivity-measurement instrument. Monitoring of the radioactivity of the effluent can be done with an NaI scintillator or an NA102A plastic scintillation-tube detector, if necessary. In the radioactivity-measurement instrument, α sources for transplutonium elements are prepared by quick evaporation of the respective fractions and immediately submitted for α -ray spectrometry and/or γ - and X-ray spectrometry. All operations are controlled by a personal computer.

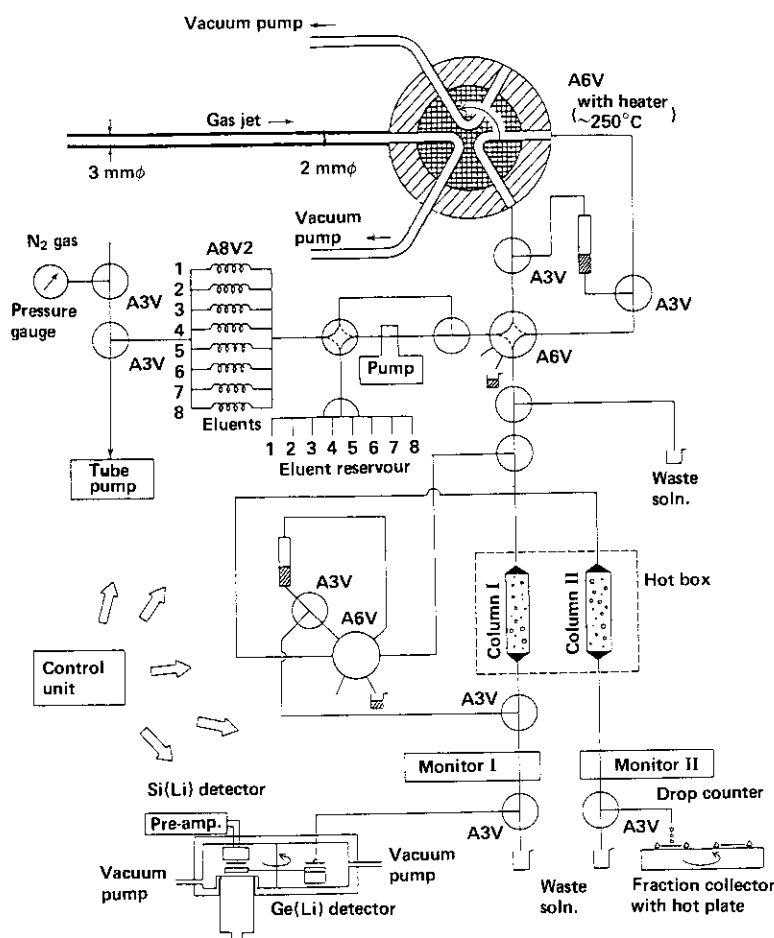

Fig. 6.38 Block diagram of on-line rapid ion-exchange separation system.

Although it is not suited for α -ray measurements, fast and continuous solvent extraction with the SISAK device [Ska 80] allows the measurement of nuclides having a shorter half-life. This was described in Section 1.2. An on-line system for the study of short-lived nuclides is summarized in **Fig. 6.39**.

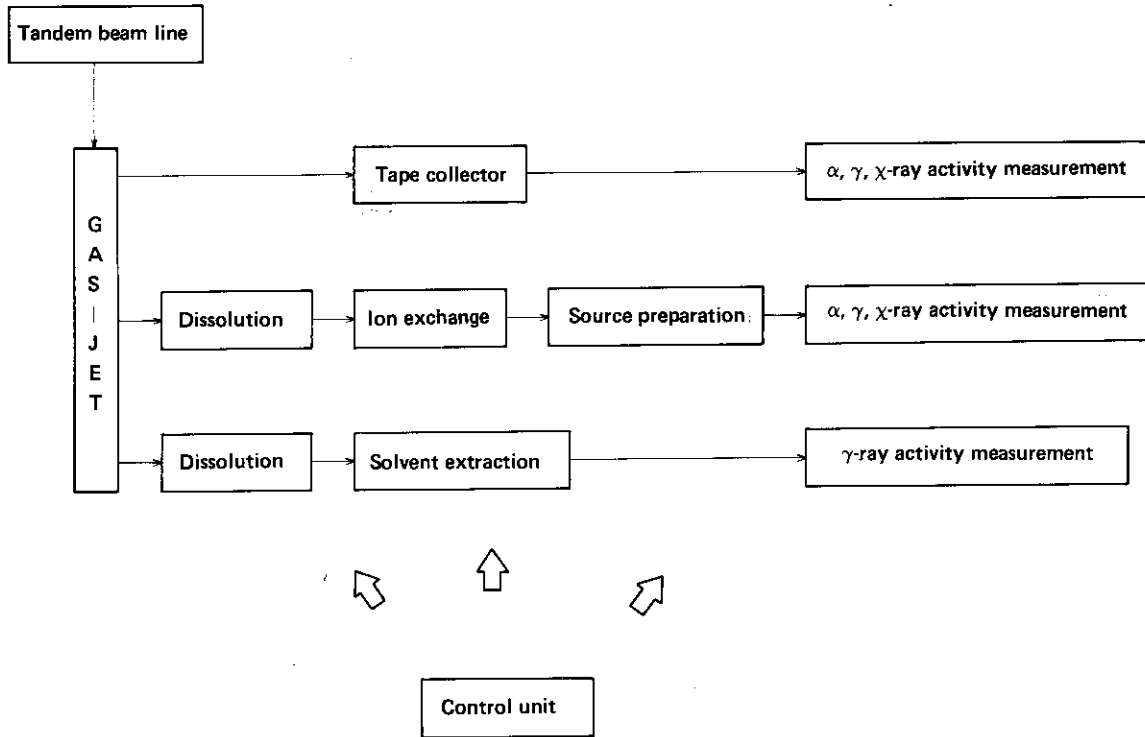

Fig. 6.39 Block diagram of on-line rapid chemical separation system.

7. Conclusions

Three methods of ion-exchange separation have been studied for investigation of short-lived transplutonium nuclides. Excellent separation was achieved by using mixed media of mineral acid (hydrochloric or nitric acid) and methanol as eluting agents at elevated temperature and pressure.

The first method was the anion-exchange separation with mixed media of nitric acid and methanol at elevated temperature. The method enabled rapid and effective intragroup-separation of the light transplutonium elements (Am to Fm) as well as that of the light lanthanoids (La to Eu) [Usu 87c, Usu 87e, Usu 87f, Usu 87g, Usu 88a]. The elements were also separated from main fission products, target material (U or Pu) and aluminium-catcher foils. The effluent of each fraction was quickly evaporated for α counting. The FWHM values of the α -ray peak were less than 20 keV even in the spectra measured with a high source-to-detector geometry, e.g., the source at 5 mm from a silicon-surface-barrier detector. The resolution was comparable to that obtained for a reference source prepared by electrodeposition. The separation method has proved to be useful not only for the identification of the atomic numbers of short-lived nuclides of Am through Fm, but also for the studies of decay properties of light transplutonium nuclides and for the search of new neutron deficient nuclides of Am, Cm and Bk.

The second method was the anion-exchange separation with mixed media of hydrochloric acid and methanol. The method enabled rapid group-separation of Am + Cm, Bk and Cf + Fm from alkali, alkaline earth, rare-earth elements, Th, U, Pu, Np, Fe, Al, Cu and other elements at elevated temperature [Usu 87d, Usu 87e, Usu 87f, Usu 88a]. The Cf + Fm or Bk fraction was immediately prepared as a counting source suitable for α -ray spectrometry. The separation factor between the transplutonium and rare-earth elements increased with increasing concentration of hydrochloric acid, being about 40 at 1.3 M HCl-90% CH₃OH. In order to investigate the separation of short-lived transplutonium nuclides with only single column, more effective separation of the transplutonium elements from fission products including the rare earths and other reaction products might be necessary. Alcoholic solvents containing ultra-concentrated chloro-ion formed by dissolving HCl gas or adding LiCl or NH₄Cl are recommended for that purpose.

The third method was the cation-exchange separation with mixed media of mineral acid and organic solvent at elevated temperature. This method was suited for concentration of transplutonium elements and elimination of the macro amounts of uranium target and so on. The transplutonium elements were then separated in a group from rare-earth elements with concentrated hydrochloric acid, or were mutually separated with the α -hydroxyisobutyrate solution [Usu 87b, Usu 88a]. The method was very effective for pre-separation of the transplutonium elements.

Combined use of two of the methods allowed an isolation of each transplutonium element in high purity. Consequently, the γ and X rays of the transplutonium nuclides with small cross sections could be detected, as demonstrated in the study of the decay property of ²⁴⁵Cf [Shi 87a, Mag 87].

In such separation methods, drops of the effluent were evaporated directly on a counting disk for the α -ray measurement [Usu 88a]. The technique was very simple, and the chemical yields were nearly 100% for transplutonium elements.

For the automated separation of short-lived transplutonium nuclides formed in the actinide targets bombarded with heavy-ions in the JAERI tandem accelerator, an on-line ion-exchange-separation system has been designed [Usu 86]. It can operate with one or two of the ion-exchange-separation schemes developed in this report. The system can be used in combination with a gas-jet recoil transportation apparatus, a tape collector, fast and continuous solvent-extraction devices (SISAK) and a radioactivity measurement instrument. Transplutonium nuclides with half-lives of longer than one minute will be

studied by use of the system.

The ion-exchange-separation methods developed in this report have a wide variety of applications. The methods have already been applied not only to the nuclear chemical studies of transplutonium nuclides [Shi 83, Shi 84, Shi 85a, Shi 85b, Mag 86, Shi 86a, Shi 86b, Mag 87, Shi 87a], but also to the analysis of spent nuclear fuel specimens for burn-up measurements [Usu 88b]. In recent years the transplutonium elements in biological and environmental samples have been often separated for the environmental assesment using the ion-exchange method with aqueous and organic solvents [Hol 76, Hol 78, Kna 79, The 80, Yam 82, Hay 87, Sak 87, Kaw 87]. The isotope ^{242}Cm in curie quantities has also been purified from a neutron-irradiated americium target using an anion-exchange method with $\text{HNO}_3\text{-CH}_3\text{OH}$ media at ambient temperature [Yao 87]. The methods described in this report provide faster and more effective separation of transplutonium elements for these purposes.

Acknowledgements

The author would like to express his thanks to Prof. Hiromichi NAKAHARA of the Tokyo Metropolitan University for many valuable discussions and suggestions during the course of this study.

The author also wished to thank Dr. Hirokazu UMEZAWA of the Japan Atomic Energy Research Institute (JAERI) for his helpful discussions and suggestions throughout this study and for his comments about this manuscript.

The author is deeply indebted to Mr. Nobuo SHINOHARA, Mr. Toshio SUZUKI, Mr. Shin-ichi ICHIKAWA, Mr. Masaaki MAGARA and Dr. Hiroshi OKASHITA of JAERI, Mr. Hideki YOSHIKAWA and Mr. Yuuichi HATSUKAWA of the Tokyo Metropolitan University, Dr. Seiichi SHIBATA of the University of Tokyo and Dr. Takayoshi HORIGUCHI of the Hiroshima University, who are the members of the nuclear-chemistry group at the JAERI tandem accelerator, for their assistance in the production and radioactivity measurement of the short-lived transplutonium nuclides synthesized by heavy-ion bombardments.

Thanks are due to Prof. Hiroshi BABA and Prof. Tadashi YAMAMOTO of the Osaka University, Prof. Ichiroh FUJIWARA of the Ottemongakuin University, and to Dr. Kenmei HIRANO, Dr. Enzo TACHIKAWA, Mr. Iwao KOBAYASHI and Dr. Sho-ichi TACHIMORI of JAERI for their continuous interest and encouragement.

studied by use of the system.

The ion-exchange-separation methods developed in this report have a wide variety of applications. The methods have already been applied not only to the nuclear chemical studies of transplutonium nuclides [Shi 83, Shi 84, Shi 85a, Shi 85b, Mag 86, Shi 86a, Shi 86b, Mag 87, Shi 87a], but also to the analysis of spent nuclear fuel specimens for burn-up measurements [Usu 88b]. In recent years the transplutonium elements in biological and environmental samples have been often separated for the environmental assesment using the ion-exchange method with aqueous and organic solvents [Hol 76, Hol 78, Kna 79, The 80, Yam 82, Hay 87, Sak 87, Kaw 87]. The isotope ^{242}Cm in curie quantities has also been purified from a neutron-irradiated americium target using an anion-exchange method with $\text{HNO}_3\text{-CH}_3\text{OH}$ media at ambient temperature [Yao 87]. The methods described in this report provide faster and more effective separation of transplutonium elements for these purposes.

Acknowledgements

The author would like to express his thanks to Prof. Hiromichi NAKAHARA of the Tokyo Metropolitan University for many valuable discussions and suggestions during the course of this study.

The author also wished to thank Dr. Hirokazu UMEZAWA of the Japan Atomic Energy Research Institute (JAERI) for his helpful discussions and suggestions throughout this study and for his comments about this manuscript.

The author is deeply indebted to Mr. Nobuo SHINOHARA, Mr. Toshio SUZUKI, Mr. Shin-ichi ICHIKAWA, Mr. Masaaki MAGARA and Dr. Hiroshi OKASHITA of JAERI, Mr. Hideki YOSHIKAWA and Mr. Yuuichi HATSUKAWA of the Tokyo Metropolitan University, Dr. Seiichi SHIBATA of the University of Tokyo and Dr. Takayoshi HORIGUCHI of the Hiroshima University, who are the members of the nuclear-chemistry group at the JAERI tandem accelerator, for their assistance in the production and radioactivity measurement of the short-lived transplutonium nuclides synthesized by heavy-ion bombardments.

Thanks are due to Prof. Hiroshi BABA and Prof. Tadashi YAMAMOTO of the Osaka University, Prof. Ichiroh FUJIWARA of the Ottemongakuin University, and to Dr. Kenmei HIRANO, Dr. Enzo TACHIKAWA, Mr. Iwao KOBAYASHI and Dr. Sho-ichi TACHIMORI of JAERI for their continuous interest and encouragement.

Appendix A Instruction Manual for the Pressurized Ion-Exchange-Separation Apparatus

A.1 Setup of the apparatus

The pressurized ion-exchange-separation apparatus (refer to **Fig. 2.1**) is set up as follows:

- 1) Attach the 3-way valve and the coupled 4-way valve made of Teflon to the burette support. Connect two spiral Teflon tubes (o.d.: 3 mm, i.d.: 2 mm, l: ca. 3.2 m) to the coupled 4-way valve. See **Photo. 1**.
- 2) Connect the tube pump and the coupled 4-way valve with a Teflon tube (o.d.: 2 mm, i.d.: 1 mm).
- 3) Attach a Teflon tube (ϕ 1 mm \times ca. 40 cm) to the coupled 4-way valve for introducing a sample solution and/or eluents.
- 4) Install a pressure regulator (< 4 MPa) on a nitrogen-gas cylinder, and connect this regulator and the 3-way valve with a Teflon tube (o.d.: 3 mm, i.d.: 2 mm).
- 5) Join a prepared column (see Appendix A.2) and the coupled 4-way valve with a Teflon tube (o.d.: 2 mm, i.d.: 0.5 mm). Provide the column with a water bath or an air bath regulated to maintain 90°C (see **Photo. 2**).
- 6) Set up, if needed, a well-type NaI(Tl) scintillation detector or an NA102A scintillation tube detector (see **Photo. 3**), and connect the column and the detector with a Teflon tube (o.d.: 2 mm, i.d.: 0.5 mm).
- 7) Connect the detector, or column is no detector is used, and a drop counter with a Teflon tube (o.d.: 2 mm, i.d.: 0.5 mm).
- 8) Put a small volume beaker or a tantalum disk (ϕ 24 mm \times 0.05 mm thick) on a quartz-glass plate (10 cm \times 10 cm) heated by a hot plate. Carefully control the hot plate temperature (see **Photo. 4**).

A.2 Column preparation for the apparatus

The ion-exchange-resin column (see **Fig. 2.2** and **Photo. 5**) for the pressurized ion-exchange-separation apparatus is constructed as follows:

- 1) Determine the size (volume) of the column desired using **Table 2.2**. Cut a Diflon (or Teflon) tube to obtain the required volume of the column.
- 2) Install a Diflon joint nut on each end of the tube. Expand both ends of the tube to trumpet shape with a hot soldering iron.
- 3) Install plugs of quartz wool one after another (length: ca. 1–2 cm) into one end of the tube with a glass bar ($< \phi$ 1.5 mm), and connect a Diflon joint (i.d.: 0.5 mm) with the nut on that end of the tube.
- 4) Introduce the required volume of resin (see **Table 2.1**) together with water into the tube from a resin reservoir (**Photo. 6**) using nitrogen-gas pressure (ca. 1 MPa).
- 5) Install plugs of quartz wool one after another (length: ca. 1–2 cm) into the other end of the tube, and connect a Diflon joint (i.d.: 0.5 mm) with the other nut.
- 6) Wash the resin with about 5 ml of 4 M hydrochloric or nitric acid, 5 ml or distilled water and 10 ml

- 7) Determine the weight of the resin, if necessary, after drying at 90°C and keeping it in a desiccator at room temperature for several hours.

A.3 Operating procedure for the apparatus

After preparation of the sample solution, the elements in question can be separated by operating the pressurized ion-exchange-separation apparatus (refer **Fig. 2.1**) as follows:

- 1) Draw a previously measured volume of wash solution (less than ca. 5 ml) into the spiral tube- I with the tube pump.
- 2) Draw the sample solution (less than ca. 5 ml) into the same spiral tube. To avoid mixing of the wash solution and the sample solution, a small volume of air is intentionally introduced between the two solutions.
- 3) Open the valve of the nitrogen-gas cylinder.
- 4) Turn the handle of coupled 4-way valve to the "up" position and then turn the handle of the 3-way valve to the "down" position. Adjust the nitrogen pressure (0.1-4 MPa) to provide the desired flow rate by control of the pressure regulator. (The nitrogen gas is supplied to the spiral tube- I and the sample and wash solutions are transferred into the column.)
- 5) Collect the solutions passed through the column in a 5- or 10-ml beaker.
- 6) Draw the first eluent (up to 10 ml) into the spiral tube- II during flow of the solutions in the tube - I .
- 7) Turn the handle of the 3-way valve to the "up" position after the solutions in the tube- I have left from the column. (The nitrogen-gas flow is stopped and the pressure in the tube- I and the column is reduced to the ambient.)
- 8) Turn the handle of the coupled 4-way valve to the "up" position and then turn the handle of the 3-way valve to the "down" position to introduce the first eluent into the column.
- 9) Repeat the above operations, interchanging the two spiral tubes for successive eluents.
- 10) Place the eluted drops directly in the centre of the heated tantalum disk (ϕ 24 mm \times 0.05 mm thick). If the effluent has a large volume, it should be collected in a 5-ml heated beaker and transferred to the disk after most of the effluent has been evaporated.
- 11) Carefully evaporate the drops on the disk by control of the hot-plate temperature.
- 12) Shut the valve on the nitrogen-gas cylinder.

The counting disks are further prepared for α -activity measurements by exposure to gas-burner flame for a few seconds.

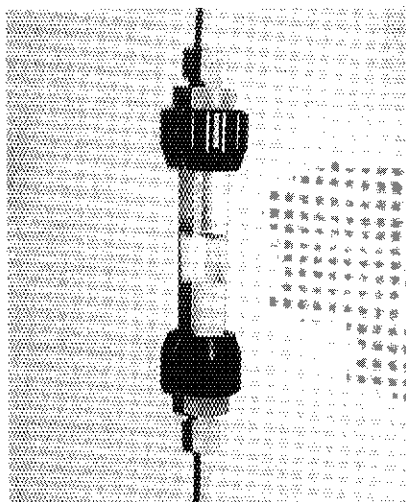

Photo. 6 Resin reservoir for column preparation.

Appendix B Ion-Exchange Separation of Actinide Elements with Mineral Acid Eluents Using the Pressurized Ion-Exchange-Separation Apparatus

The use of the pressurized ion-exchange-separation apparatus was examined for conventional ion-exchange separations of some actinide elements with aqueous mineral acid solutions [Fig 60, Nat 72]. The system was then applied to separation of the transplutonium nuclides produced by the $^{16}\text{O} + ^{238}\text{U}$ reaction [Shi 84].

B.1 Anion-exchange separation with hydrochloric acid solutions

The actinide elements (Pa, U, Np, Pu, Am and Cm) were separated by the anion-exchange method [Nat 72] using the apparatus at room temperature. The column was of ϕ 2 mm \times 8 cm long and was packed with 0.25 ml of the CA08Y resin. The sample solution was previously treated by redox with $\text{NH}_2\text{OH} \cdot \text{HCl}$ and concentrated HNO_3 to adjust the Np and Pu valence. **Figure A.1** shows the elution curves with mixtures of HCl and another mineral acid (HNO_3 , HF or HI). The transplutonium elements were passed through the column together with some quantities of Pu and Np with 9 M HCl-0.1 M HNO_3 solution. Protactinium was eluted with 9 M HCl-0.1 M HF solution followed by the gradual elution of Np. The remaining Np and the majority of the Pu were eluted with 4 M HCl-0.1 M HI solution. The U was recovered with 0.1 M HCl solution. Flow rate was 7 to 14 cm/min.

The method is applicable for the mutual separation of actinide elements with $Z \leq 94$. If an aluminium-catcher foil is dissolved in the solution, it is impossible to perform α -activity measurement of the transplutonium fraction due to the voluminous quantity of aluminium chloride which is also eluted in the same fraction.

B.2 Cation-exchange separation with hydrochloric acid solutions

Cation-exchange separation of the transplutonium elements with hydrochloric acid solutions [Fig 60] was also examined using the apparatus. **Figure A.2** shows the elution curves for separation of Am and Cm tracers from fission products, 1.1 mg of U (target material) and 3.2 mg of Al (catcher foil) at 90°C with a flow rate of 22-30 cm/min. The Al that exceeded the resin capacity was passed through the column with 1 M HCl solution and then Cs, U, Sr and the residual amounts of Al were eluted. The transplutonium elements accompanied with the rare-earth elements were eluted with 4 M HCl solution. To avoid aluminium contamination in the transplutonium fraction, the first few drops of 4 M HCl effluent were discarded.

The recovery of the transplutonium elements was about 90%. It took about 20 min to separate the transplutonium elements from the U, Al and fission products and to prepare the α -counting source.

B.3 Rapid separation of ^{250}Fm and ^{246}Cf from a ^{238}U target bombarded with ^{16}O ions

Based on the techniques described in the previous section, the rapid cation-exchange separation of the transplutonium nuclides synthesized by the $^{16}\text{O} - ^{238}\text{U}$ reaction was performed.

A thick ^{238}U target (1.8 mg/cm²) with an aluminium backing (ca. 4 mg) was irradiated and dissolved

in concentrated HCl in a 5-ml beaker under an infrared lamp. Concentrated HNO₃ was added to the beaker to dissolve the sample completely and to oxidize the U(IV) and the other actinide elements. The solution was then heated and evaporated to near-dryness. The residue was redissolved in a small volume of ≤ 1 M HCl solution. Separation of the transplutonium nuclides was performed according to the flow diagram shown in **Fig. A.3**. To minimize the residue of the transplutonium fraction, the transplutonium elements were eluted with 4 M HCl solution purified by distillation.

The counting source on a tantalum disk was prepared by exposing it to a gas-burner flame. **Figure A.4** shows the α -ray spectrum of the transplutonium fraction. The FWHM values of peaks were about 50 keV.

By measurement of their α -particle energies and half-lives, ²⁵⁰Fm and ²⁴⁶Cf ($T_{1/2}$: 30 min and 35.7 h, α : 7.43 MeV and 6.76 MeV, respectively) [Led 78] were successfully identified [Shi 84].

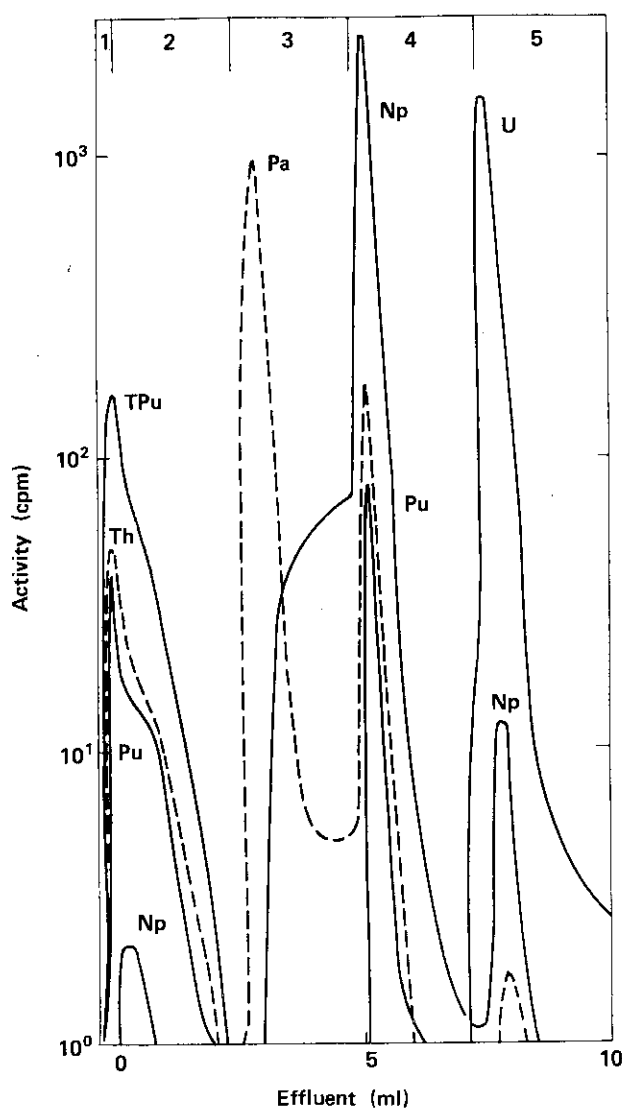

Fig. A.1 Anion-exchange separation of the actinide elements with hydrochloric acid solutions containing other selected mineral acids at room temperature. Column bed: ϕ 2 mm \times 8 cm, resin: CA08Y (0.25 ml), flow rate: 7~14 cm/min, 1: sample solution (9 M HCl-0.1 M HNO₃, 0.5 ml), 2: 9 M HCl-0.1 M HNO₃ (2.5 ml), 3: 9 M HCl-0.1 M HF (2.5 ml), 4: 4 M HCl-0.1 M HI (2.5 ml), 5: 0.1 M HCl (2.5 ml), —: α activity, - - - : β activity.

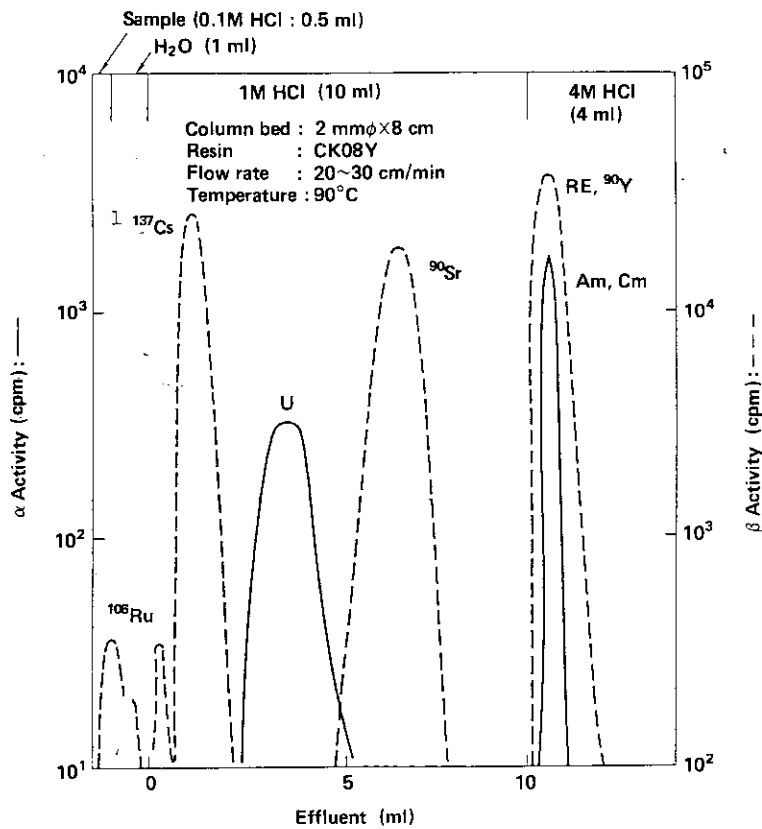

Fig. A.2 Cation-exchange separation of the transplutonium elements from a mixture of fission products, uranium (1.1 mg) and an aluminium foil (3.2 mg) with hydrochloric acid solutions.

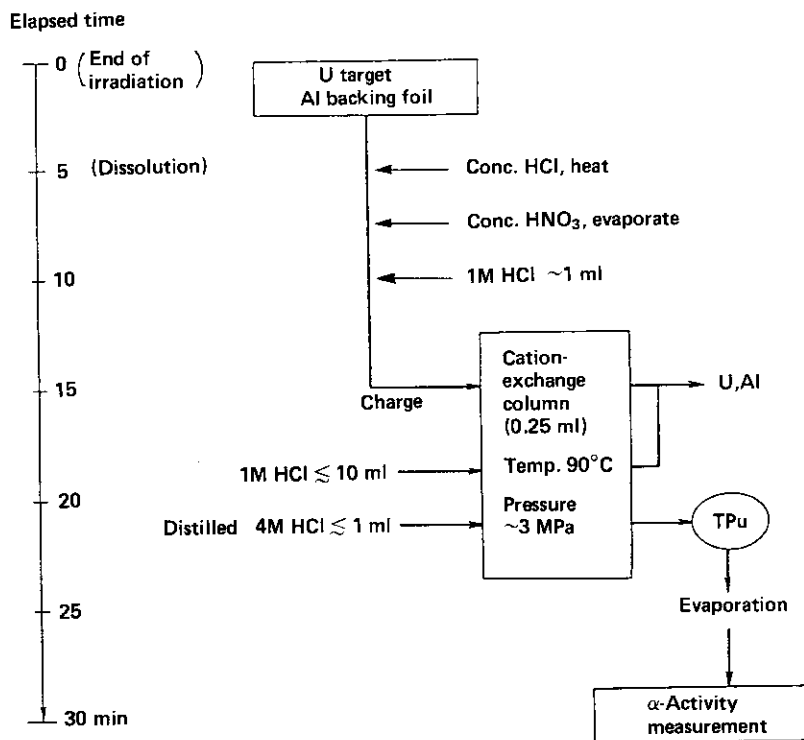

Fig. A.3 Flow diagram for the rapid ion-exchange separation of transplutonium elements from a heavy-ion bombarded uranium target with an aluminium foil.

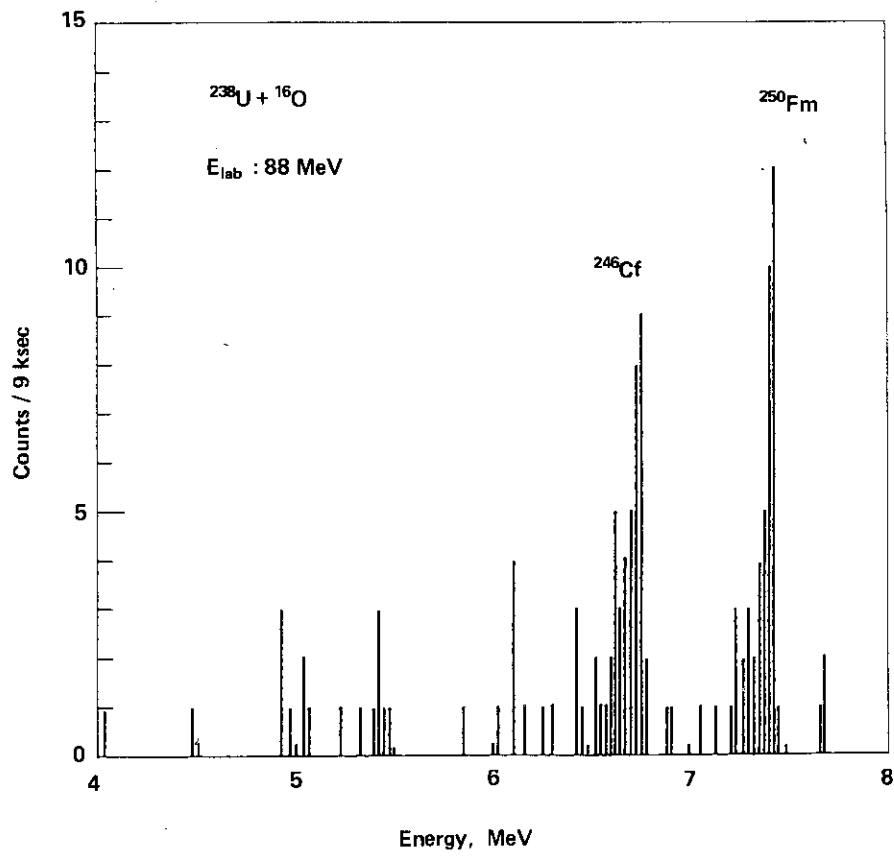

Fig. A.4 Alpha-ray spectrum of the transplutonium fraction after the ion-exchange separation.

References

- Abe 71 R.M. Abernathy, G.M. Matlack, J.E. Rein: IAEA-SM-149/37, p.513 (1971).
- Ada 63 S. Adar, R.K. Sjoblom, R.F. Barnes, P.R. Fields, E.K. Hulet, H.D. Wilson: *J. Inorg. Nucl. Chem.*, 25, 447 (1963).
- Ahm 66 I. Ahmad: UCRL-16888 (1966).
- Ahm 86 I. Ahmad, P.R. Fields: "The Chemistry of the Actinide Elements, 2nd Edition, Vol.2", edit by J.J. Katz, G.T. Seaborg and L.R. Morss, Chapman and Hall, London, p.1649 (1986).
- Aka 66 G.N. Akap'ev, A.G. Demin, V.A. Druin, E' G. Imaev, I.V. Kolesov, Yu. V. Lobanov, L.P. Pashchenko: *Amonaya Energiya*, 21, 243 (1966).
- Ale 77 B.M. Aleksandrov, L.P. Malysheva, G.P. Sevostkina, E.A. Smirnova, A.S. Krivokhat-skki: *Radiokhimiya*, 19, 472 (1977).
- Ami 57 S. Amiel, A. Chetham-Strode, Jr., G.R. Choppin, A. Ghiorso, B.G. Harvey, L.W. Holm, S.G. Thompson: *Phys. Rev.*, 106, 553 (1957).
- AST 85 "1985 Annual Book of ASTM Standards", Vol.12.02, Designation: E321-79, p.156 (1985).
- Aum 74 D.C. Aumann, G. Müllen: *Nucl. Instr. Methods*, 115, 75 (1974).
- Bak 81 J.D. Baker, R.J. Gehrke, R.C. Greenwood, D.H. Meikrantz: *Radiochimica Acta*, 28, 51 (1981).
- Bak 82 J.D. Baker, R.J. Gehrke, R.C. Greenwood, D.H. Meikrantz: *J. Radioanal. Chem.*, 74, 117 (1982).
- Bar 85 S.W. Barwick, P.B. Price, J.D. Stevenson: *Phys. Rev. C*, 31, 1984 (1985).
- Ber 58 E.W. Berg, J.T. Truemper: *Anal. Chem.*, 30, 1827 (1958).
- Bla 75 M. Blann, J. Bisplinghoff: COO-3494-27 (1975).
- Bla 76 M. Blann: COO-3494-29 (1976).
- Boc 65 V.B. Bochkarev, E.N. Voevodin: *Radiokhimiya*, 7, 461 (1965).
- Bon 75 W.D. Bond, R.E. Leuze: ORNL-5012 (1975).
- Bro 81 K. Brodén, G. Skarnemark, T. Björnstad, D. Eriksen, I. Haldorsen, N. Kaffrell, E. Stender, N. Trautmann: *J. Inorg. Nucl. Chem.*, 43, 765 (1981).
- Bro 82 K. Brodén, H. Persson, J. Rydberg, G. Skarnemark: *Nucl. Instr. Methods*, 195, 539 (1982).
- Buc 65 K. Buchtera, K. Aitzetuller, F. Grass: *Atomkernenenergie*, 10-44, 264 (1965).
- Buc 70 K. Buchtera: *Atomkernenenergie*, 15-59, 293 (1970).
- Bun 59 L.R. Bunney, N.E. Ballou, J. Pascual, S. Foti: *Anal. Chem.*, 31 324 (1959).
- Bur 73 J.H. Burns, J.R. Perterson, R.D. Baybrz: *J. Inorg. Nucl. Chem.*, 35, 1171 (1973).
- Cam 70a D.O. Campbell, S. Buxton: *Ind. Eng. Chem. Process Des. Dev.*, 9, 89 (1970).
- Cam 70b D.O. Campbell: *Ind. Eng. Chem. Process Des. Dev.*, 9, 95 (1970).
- Cam 73 D.O. Campbell: *J. Inorg. Nucl. Chem.*, 35, 3911 (1973).
- Cas 86 R.M. Cassidy, S. Elchuk, N.L. Elliot, L.W. Green, C.H. Knight, B.M. Recoskie: *Anal. Chem.*, 58, 1181 (1986).
- Cha 56a A. Chetham-Strode, Jr., G.R. Choppin, B.G. Harvey: *Phys. Rev.*, 102, 747 (1956).
- Che 56b A. Chetham-Strode, Jr.: UCRL-3322 (1956).
- Cho 56a G.R. Choppin, B.G. Harvey, S.G. Thompson: *J. Inorg. Nucl. Chem.*, 2, 66 (1956).
- Cho 56b G.R. Choppin, R.J. Silva: *J. Inorg. Nucl. Chem.*, 3, 153 (1956).
- Cho 60 G.R. Choppin, A. Chatham-Strode: *J. Inorg. Nucl. Chem.*, 15, 377 (1960).
- Cho 62 G.R. Choppin, R.H. Dinius: *Inorg. Chem.*, 1, 140 (1962).
- Cho 84 G.R. Choppin: *Sep. Sci. Technol.*, 19, 911 (1984-1985).

- Chu 69 Yu.T. Chuburkov, V.Z. Belov, R. Caletka, M.R. Shalavsky, I. Zvara: *J. Inorg. Nucl. Chem.*, 31, 3113 (1969).
- Col 69 J.S. Coleman, L.B. Asprey, R.C. Chisholm: *J. Inorg. Nucl. Chem.*, 31, 1167 (1969).
- Cum 68 T.F. Cummings, J. Korkisch: *Anal. Chim. Acta*, 40, 520 (1968).
- Dav 86 F. David: *J. Less-Common Metals*, 121, 27 (1986).
- Dia 54 R.M. Diamond, K. Street, Jr., G.T. Seaborg: *J. Amer. Chem. Soc.*, 76 1461 (1954).
- Duf 88 P. Dufek, M. Vobecký, J. Holik, J. Valasek: *J. Chromatog*, 435, 249 (1988).
- Edg 63 R.A. Edge: *Anal. Chim. Acta*, 29, 321 (1963).
- Ele 79 A.A. Elesin, V.A. Karaseva, V.I. Frolov: *Radiokhimiya*, 21, 511 (1979).
- Ele 86 A.A. Elesin, V.M. Nikolaev, V.V. Shalimov, Yu.S. Popov, V.N. Kovantsev, I.V. Tselishchev, V.T. Filimonov, V.B. Mishenev, A.A. Yadovin, L.S. Golosovskii, A.P. Chetverikov, Yu.V. Efremov: *Radiokhimiya*, 28, 786 (1986).
- Ell 86 N.L. Elliot, L.W. Green, B.M. Recoskie, R.M. Cassidy: *Anal. Chem.*, 58, 1178 (1986).
- Eri 79 E.A. Erin, V.M. Vitytnev, V.V. Kopytov, V.Ya. Vasil'ev: *Radiokhimiya*, 21, 560 (1979).
- Far 62 J.P. Faris, J.W. Walton: *Anal. Chem.*, 34 1077 (1962).
- Far 69 J.J. Fardy, B. Weaver: *Anal. Chem.*, 41, 1299 (1969).
- Feb 86 S.N. Fedotov, A.V. Yablochkin, *Radiokhimiya*, 28, 266 (1986).
- Fed 87 E.V. Fedoseev, M.I. Aizenberg, S.N. Timokhin, S.S. Travnikov, I. Zvara, A.V. Davydov, B.F. Myasoedov: *J. Radioanal. Nucl. Chem., Letters*, 119, 347 (1987).
- Fie 57 P.R. Fields, A.M. Friedmann, J. Milsted, H. Atterling, W. Forling, L.W. Holm and B. Astrom: *Phys. Rev.*, 107, 1460 (1957).
- Fie 67 P.R. Fields, R.F. Barnes, R.K. Sjolom, J. Milsted: *Phys. Letters*, 24B, 340 (1967).
- Fow 86 M.M. Fowler, W.R. Daniels, H.R. Von Gunten, H. Gäggeler, D.C. Hoffman, D. Lee, K. Gregorich, K. J. Moody, M. Lerch, G. Herrmann, N. Trautmann: *Radiochimica Acta*, 40, 75 (1986).
- Fri 61 J.S. Fritz, D.I. Pietrzyk: *Talanta*, 8, 143 (1961).
- Fri 62 J.S. Fritz, T.A. Retting: *Anal. Chem.*, 34, 1562 (1962).
- Fri 63 A.M. Friedmann, J. Milsted: *Phys. Rev.*, 131, 772 (1963).
- Fuj 63 T. Fujino: *Nippon Genshiryoku Gakkaishi*, 5, 640 (1963).
- Fuj 85 I. Fujiwara: Private communication (1985).
- Gat 59 R.C. Gatti, L. Phillips, T. Sikkeland, M.I. Muga, S.G. Thompson: *J. Inorg. Nucl. Chem.*, 11, 251 (1959).
- Gav 66 K.A. Gavrilov, E. Gvuzdz, J. Starý, Wang Tung Seng: *Talanta*, 13, 471 (1966).
- Ghi 55a A. Ghiorso, B.G. Harvey, G.R. Choppin, S.G. Thompson, G.T. Seaborg: *Phys. Rev.*, 98, 1518 (1955).
- Ghi 55b A. Ghiorso, S.G. Thompson, G.H. Higgins, G.T. Seaborg, M.H. Studier, P.R. Fields, S.M. Fried, H. Diamond, J.F. Mech, G.L. Pyle, J.R. Huizenga, A. Hirsch, W.M. Manning, C.I. Browne, H.L. Smmith, R.W. Spence: *Phys. Rev.*, 99, 1048 (1955).
- Ghi 58 A. Ghiorso, T. Sikkeland, J.R. Walton, G.T. Seaborg: *Phys. Rev. Lett*, 1, 18 (1958).
- Glu 55 E. Glueckauf: *Trans. Faraday Soc.*, 51, 34 (1955).
- Gre 84 L.W. Green, C.H. Knight, T.H. Loughurst, R.M. Cassidy: *Anal. Chem.*, 56, 696 (1984).
- Gri 62 C. Grigorescu-sabau: *J. Inorg. Nucl. Chem.*, 24, 195 (1962).
- Gus 70 L.I. Guseva, G.S. Tikhomirova: *Radiokhimiya*, 12, 771 (1970).
- Gus 71 L.I. Guseva, S.I. Grigor'eva, G.S. Tikhomirova: *Radiokhimiya*, 13, 778 (1971).
- Gus 72 L.I. Guseva, G.S. Tikhomirova: *Radiokhimiya*, 14, 188 (1972).
- Gus 73a L.I. Guseva, B.F. Myasoedov, G.S. Tikhomirova, L.I. Pavelenko, G.G. Babicheva: *J. Radioanal. Chem.*, 13, 293 (1973).
- Gus 73b L.I. Guseva, G.S. Tikhomirova, S.I. Grigor'eva: *Radiokhimiya*, 15, 397 (1973).
- Gus 73c L.I. Guseva, G.S. Tikhomirova: *Radiokhimiya*, 15, 401 (1973).
- Gus 75 L.I. Guseva, I.A. Lebedev, B.F. Myasoedov, G.S. Tikhomirova: *Radiokhimiya*, 17, 321 (1975).

- Gus 76 L.I. Guseva, I.A. Lebedev, B.F. Myasoedov, G.S. Tikhomirova: *J. Inorg. Nucl. Chem.*, Supplement p.55 (1976).
- Gus 84 L.I. Guseva, G.S. Tikhomirova: *Radiokhimiya*, 26, 764 (1984).
- Gus 85 L.I. Guseva, G.S. Tikhomirova, V.V. Stepushkina: *J. Radioanal. Chem.*, 90, 15 (1985).
- Hai 73 N.Von Haidvogel, G. Reitsamer, F. Grass: *Atomkenergie*, 22, 117 (1973).
- Ham 60 P.B. Hamilton, D.C. Bogue, R.A. Anderson: *Anal. Chem.*, 32, 1782 (1960).
- Hay 87 N. Hayashi, J. Ishida, A. Yamato, M. Iwai, M. Kinoshita: *J. Radioanal. Nucl. Chem.*, 115, 369 (1987).
- Hei 81 O.J. Heinonen: *Radiochem. Radioanal. Letters*, 47, 299 (1981).
- Hig 60 G.H. Higgins: *NAS-NS* 303 (1960).
- Hin 62 J. Hines, M.A. Wahlgren, F. Lawless: *TID-7655*, p.247 (1962).
- Hol 76 E. Holm, R. Fukai: *Talanta*, 23, 853 (1976).
- Hol 78 E. Holm, R.B.R. Persson: *Rad. Environm. Biophys.*, 15, 261, (1978).
- Hor 67 E.P. Horwitz, L.J. Sauro, C.A.A. Bloomquist: *J. Inorg. Nucl. Chem.*, 29, 2033 (1967).
- Hor 69a E.P. Horwitz, C.A.A. Bloomquist, D.J. Henderson: *J. Inorg. Nucl. Chem.*, 31, 1149 (1969).
- Hor 69b E.P. Horwitz, C.A.A. Bloomquist, D.J. Henderson, E.D. Nelson: *J. Inorg. Nucl. Chem.*, 31, 3255 (1969).
- Hor 73 E.P. Horwitz, C.A.A. Bloomquist: *J. Inorg. Nucl. Chem.*, 35, 271 (1973).
- Hor 74 E.P. Horwitz, C.A.A. Bloomquist: *J. Chromatog. Sci.*, 12, 200 (1974).
- Hor 75 E.P. Horwitz, C.A.A. Bloomquist: *J. Inorg. Nucl. Chem.*, 37, 425 (1975).
- Hor 77 E.P. Horwitz, C.A.A. Bloomquist, W.H. Delphin: *J. Chromatog. Sci.*, 15, 41 (1977).
- Hse 81 K-C. Hseuh, E-M. Franz, P.E. Haustein, S. Katcoff, L.B. Peter: *Phys. Rev. C*, 23, 1217 (1981).
- Hub 80 S. Hübener, I. Zvára: *Radiochimica Acta*, 27, 157 (1980).
- Hub 82 S. Hübener, I. Zvára: *Radiochimica Acta*, 31, 89 (1982).
- Hul 51 E.K. Hulet, G.S. Thompson, A. Ghiorso, K. Street. Jr.: *Phys. Rev.*, 84, 366 (1951).
- Hul 53 E.K. Hulet: *UCRL-2283* (1953).
- Hul 61 E.K. Hulet, R.G. Gutmacher, M.S. Coops: *J. Inorg. Nucl. Chem.*, 17, 350 (1961).
- Hul 72 E.K. Hulet, D.D. Bode: "MTP International Review of Science, Series One, Vol.7, Lanthanides and Actinides", edited by K.W. Bagnall, Butterworths, London, p.1 (1972).
- Hul 79 E.K. Hulet, R.W. Loughheed, P.A. Baisden, J.H. Landrum, J.F. Wild, R.F.D. Lundqvist: *J. Inorg. Nucl. Chem.*, 41, 1743 (1979).
- Ich 61 F. Ichikawa, S. Uruno, H. Imai: *Bull. Chem. Soc. Japan* 34, 952 (1961).
- KAG 84 "Kagaku Binran, 3rd Edition", edited by the Chemical Society of Japan, Maruzen Co., Ltd., Tokyo (1984).
- Kam 85 A.N. Kamenskaya, N.B. Mikheev, S.A. Kulyukhin, N.A. Konolova: *Radiokhimiya*, 27, 837 (1985).
- Kas 87 F.D. Kasimov, N.F. Skobelev: *Radiokhimiya*, 30, 614 (1987).
- Kat 57 J.J. Katz, G.T. Seaborg: "The Chemistry of the Actinide Elements", John Wiley and Sons, Inc., New York (1957).
- Kat 86 J.J. Katz, G.T. Seaborg, L.R. Morss: "The Chemistry of the Actinide Elements, 2nd Edition, Vol.2", Chapman and Hall, London (1986).
- Kaw 87 H. Kawamura: *Health Physics*, 52, 793 (1987).
- Kna 79 D. Knab: *Anal. Chem.*, 51, 1095 (1979).
- Kor 61 J. Korkisch, F. Tera: *Anal. Chem.*, 33, 1264 (1961).
- Kor 62 J. Korkisch, G.E. Janauer: *Talanta*, 9, 957 (1962).
- Kor 63 J. Korkisch, I. Hazan, G. Arrhenius: *Talanta*, 10, 865 (1963).
- Kor 64a J. Korkisch, I. Haxan: *Talanta*, 11, 530 (1964).
- Kor 64b J. Korkisch, I. Hazan: *Talanta*, 11, 1157 (1964).
- Kor 66a J. Korkisch: "Analytical Chemistry", Vol.6, edited by D.C. Stewart and E.A. Elion, Pergamon Press, p. 3 (1966).
- Kor 66b J. Korkisch, S.S. Ahluwalia: *Anal. Chem.*, 38, 497 (1966).

- Kor 67a J. Korkisch, S.S. Ahluwalia: *Talanta*, 14, 155 (1967).
- Kor 67b J. Korkisch, F. Feik, S.S. Ahluwalia: *Talanta*, 14, 1069 (1967).
- Kor 68 J. Korkisch, A. Huber: *Talanta*, 15, 119 (1968).
- Kor 69 J. Korkisch: "Modern Methods for the Separation of Rare Metal Ions", Pergamon Press Ltd., London (1969).
- Kos 77 V.N. Kosyakov, N.G. Yakovlev, G.H. Kazakova, E.A. Erin, V.V. Kopytov: *Radiokhimiya*, 19, 486 (1977).
- Kra 58 K.A. Kraus, F. Nelson: *Am. Soc. Testing Mater., Spec. Tech. Publ. No.195*, p.27 (1958).
- Kra 66 W. Kraak, W.A. Van Der Heijden: *J. Inorg. Nucl. Chem.*, 28, 221 (1966).
- Kul 85 S.A. Kulyukhin, L.N. Auerman, V.L. Novichenko, N.B. Mikheev, I.A. Rumer, A.N. Kamenskaya, L.A. Goncharov, A.I. Smirnov: *Radiokhimiya*, 27, 833 (1985).
- Kur 79 R. Kuroda: *Bunseki*, 1, 31 (1979), in Japanese.
- Kus 68 W. Husch, Z. Szeglowski: *JINR-E6-3992* (1968).
- Kut 85 W. Kutschera, I. Ahmad, S.G. Armato III, A.M. Friedmann, J.E. Grindler, W. Henning, T. Ishii, M. Paul, K.E. Rehm: *Phys. Rev. C*, 32, 2036 (1985).
- Leb 74 J.A. Lebedev, B.F. Myasoedov, L.I. Guseva: *J. Radioanal. Chem.*, 21, 259 (1974).
- Leb 82 I.A. Lebedev, B.F. Myasoedov: *Radiokhimiya*, 24, 700 (1982).
- Leb 78 C.M. Lederer, V.S. Shirley (eds.): "Table of Isotopes", 7th Edition, John Wiley & Sons Inc., New York (1978).
- Liu 81 Yuan-fang Liu, Cheng Luo, H.R.von Gunten, G.T. Seaborg: *Inorg. Nucl. Chem., Letters*, 17, 257 (1981).
- Liu 83 Yuan-fang Liu, Cheng Luo, K.J. Moody, D. Lee, G.T. Seaborg, H.R.von Gunten: *J. Radioanal. Chem.*, 76, 119 (1983).
- Low 71 J.T. Lowe, W.H. Hale, Jr., D.F. Hallman: *Ind. Eng. Chem. Process Des. Develop.*, 10, 131 (1971).
- Lun 81 R. Lundqvist, E.K. Hulet, P.A. Baisden: *Acta Chem. Scand.*, A 35, 653 (1981).
- Mad 86 C. Madic: *J. Less-Common Metals*, 122, 353 (1986).
- Mag 86 M. Magara, N. Shinohara, S. Usuda, S. Ichikawa, T. Suzuki, H. Okashita, Y. Yoshikawa, Y. Iwata, T. Horiguchi, S. Shibata, I. Fujiwara: The 30th Symposium on Radiochemistry in Sendai, on Oct. 22-24, 1986, Abstracts of papers, p.118 (1986), in Japanese.
- Mag 87 M. Magara, N. Shinohara, S. Usuda, S. Ichikawa, T. Suzuki, H. Iimura, Y. Nagame, Y. Kobayashi, T. Yamamoto, Y. Hatsukawa, T. Horiguchi, S. Shibata, I. Fujiwara: The 31st Symposium on Radiochemistry in Fukuoka, on Oct. 13-15, 1987, Abstracts of papers, p.14 (1987), in Japanese.
- Mak 83 T.P. Makarova, L.D. Preobrazhenskaya, A.V. Lovtysus, A.M. Fridkin, A.V. Stepanov, A.A. Lipovskii, B. N. Belyaev: *J. Radioanal. Chem.*, 80, 173 (1983).
- Mal 68 J. Maly, T. Sikkland, R.J. Silva, A. Ghiorso: *Science*, 160, 1114 (1968).
- Mar 59 Y. Marcus, F. Nelson: *J. Phys. Chem.*, 63, 77 (1959).
- Mar 61 Y. Marcus, I. Abrahamer: *IA-608* (1961).
- Mar 63 Y. Marcus, M. Givon, G.R. Choppin: *J. Inorg. Nucl. Chem.*, 25, 1457 (1963).
- Mar 69 Y. Marcus, A.S. Kertes: "Ion Exchange and Solvent Extraction of Metal Complexes", John Wiley and Sons, Ltd., London, p.9, 927, 931 (1969).
- Mil 56 J. Milsted, A.B. Beadle: *J. Inorg. Nucl. Chem.*, 3, 248 (1956).
- Mik 81 N.B. Mikheev, A.N. Kamenskaya, A. Mikulsky, T. Petryna, L.A. Rumer, L.N. Auerman, Z. Shcheglovskii: *Radiokhimiya*, 23, 927 (1981).
- Mik 83a N.B. Mikheev: *Radiokhim. Acta*, 32, 69 (1983).
- Mik 83b N.B. Mikheev, A.N. Kamenskaya, N.A. Konovalova, I.A. Rumer, S.A. Kulyukhin: *Radiokhimiya*, 25, 158 (1983).
- Mik 87 N.B. Mikheev, A.N. Kamenskaya, L.N. Auerman, S.A. Kulyukhin, I.A. Rumer, V.L. Novichenko: *Radiokhimiya*, 29, 194 (1987).
- Moo 68 G.J. Moody, J.D.R. Thomas: *Analyst*, 93, 557 (1968).

- Moo 83 K.J. Moody: LBL-16249 (1983).
- Moo 87a K.J. Moody, W. Bröchle, M. Brügger, H. Gäggeler, B. Haefner M. Schädel, K. Sümmerer, H. Tetzlaff, G. Herrmann, N. Kaffrell, J.V. Kratz, J. Rogowski, N. Trautmann, M. Skälberg, G. Skarnemark, J. Alstad, M.M. Fowler: *Z. Phys. A-Atoms and Nuclei*, 328, 47 (1987).
- Moo 87b K.J. Moody, E.K. Hulet, S. Wang, P.B. Price, S.W. Barwick: *Phys. Rev. C*, 36, 2710 (1987).
- Mor 66 R.T. Morrow: *Talanta*, 13, 1265 (1966).
- Mya 83 B.F. Myasoedov, I.A. Lebedev: *Radiochimica Acta*, 32, 55 (1983).
- Nat 71 H. Natsume, H. Umezawa, T. Tuzuki, F. Ichikawa, T. Sato, S. Baba, H. Amano: *J. Radioanal. Chem.*, 7, 189 (1981).
- Nat 72 H. Natsume, H. Umezawa, S. Okazaki, T. Suzuki, T. Sonobe, S. Usuda: *J. Nucl. Sci. Technol.*, 9, 737 (1972).
- Nat 77 H. Natsume, H. Okashita, H. Umezawa, S. Okazaki, T. Suzuki, M. Ohnuki, T. Sonobe, Y. Nakahara, S. Ichikawa, S. Usuda, S. Matsuura, H. Tsuruta, T. Suzuki, T. Komori, S. Tamura, K. Gunji, K. Tamura: *J. Nucl. Sci. Technol.*, 14, 745 (1977).
- Nav 80 J.D. Navratil, W.W. Schulz (Eds.): "Actinide Separations", American Chemical Society, Washinton D.C. (1980).
- Nik 82 V.M. Nikolaev, E.A. Karelin, V.T. Filimonov, Ya.N. Gordeev: *Radiokhimira*, 24, 648 (1982).
- Növ 81 S.I. Növik, T. Björnstad, J. Alstad, K. Brodén, G. Skarnemark: *Nucl. Instr. Methods*, 185, 175 (1981).
- Oka 86 S. Okazaki, N. Kohn: JAERI-M 85-231, p.293 (1986).
- Orl 68 K.A. Orlandini, J. Korkisch: ANL-7415 (1968).
- Pen 60 R.A. Penneman, T.K. Keenan: NAS-NS 3006 (1960).
- Pep 57 D.F. Peppard, S.W. Moline, G.W. Mason: *J. Inorg. Nucl. Chem.*, 4, 344 (1957).
- Pim 82 M. Pimple, J. Hiller, H. Schüttelkopf: RFP-TRANS-346 (1982).
- Reg 77 P.De Regge, R. Boden: *J. Radioanal. Chem.*, 35, 173 (1977).
- Rid 64 B.F. Rider, J.P. Peterson, Jr.C.P. Ruiz, F.R. Smith: GEAP-4716 (1964).
- Roe 74 I. Roelandts, G. Duyckaerts, A.O. Brunfelt: *Anal. Chimica Acta*, 73, 141 (1974).
- Ros 84 H.L. Rose, G.A. Jones: *Nature*, 307, 245 (1984).
- Sak 87 M. Sakanoue: *Radiochimica Acta*, 42, 103 (1987).
- Sam 63 O. Samuelson: "Ion Exchange Separation in Analytical Chemistry", Almqvist & Wiksell, Stockholm, John Wiley & Sons, Inc., New York (1963).
- Sch 77 M. Schädel, N. Trautmann, G. Herrmann: *Radiochimica Acta*, 24, 27 (1977).
- Sch 78 M. Schädel, W. Bröchle, B. Haefner, J.V. Kratz, W. Schorstein, N. Trautmann, G. Herrmann: *Radiochimica Acta*, 25, 111 (1978).
- Sha 76 R.D. Shannon: *Acta Crystallogr.A*, 32, 751 (1976).
- Shi 83 N. Shinohara, S. Ichikawa, S. Usuda, T. Suzuki, N. Kono, H. Umezawa, H. Okashita, T. Sekene, K. Hata, Y. Yoshizawa, T. Horiguchi, I. Fujiwara: JAERI-M 83-095, p.53 (1983).
- Shi 84 N. Shinohara, S. Ichikawa, S. Usuda, T. Suzuki, H. Okashita, T. Sekine, K. Hata, T. Horiguchi, Y. Yoshizawa, S. Shibata, I. Fujiwara: JAERI TANDEM Annual Report 1983, JAERI-M 84-129, p.57 (1984).
- Shi 85a N. Shinohara, S. Ichikawa, S. Usuda, T. Suzuki, H. Okashita, T. Sekine, K. Hata, T. Horiguchi, Y. Yoshizawa, S. Shibata, I. Fujiwara: "Americium and Curium Chemistry and Technology", edited by N.M. Edelstein et al., D. Reidel Publishing Company, Dordrecht, Netherlands, p.251 (1985).
- Shi 85b N. Shinohara, S. Usuda, S. Ichikawa, T. Suzuki, H. Okashita, Y. Yoshikawa, Y. Iwata, T. Horiguchi, Y. Yoshizawa, S. Shibata, I. Fujiwara: JAERI TANDEM, LINAC & V.D.G. Annual Report 1984, JAERI-M 85-104, p.129 (1985).
- Shi 86a N. Shinohara, S. Usuda, S. Ichikawa, T. Suzuki, M. Magara, H. Okashita, H. Yoshikawa, T. Horiguchi, Y. Iwata, S. Shibata, I. Fujiwara: *Phys. Rev. C*, 34, 909 (1986).

- Shi 86b N. Shinohara, S. Usuda, S. Ichikawa, T. Suzuki, M. Magara, H. Okashita, Y. Yoshikawa, Y. Iwata, T. Horiguchi, S. Shibata, I. Fujiwara: JAERI TANDEM, LINAC & V.D.G. Annual Report 1985, JAERI-M 86-112, p.107 (1986).
- Shi 87a N. Shinohara, M. Magara, S. Usuda, S. Ichikawa, T. Suzuki, H. Iimura, Y. Kobayashi, T. Yamamoto, Y. Nagame, Y. Hatsukawa, T. Horiguchi, S. Shibata, I. Fujiwara: JAERI TANDEM, LINAC & V.D.G. Annual Report 1986, JAERI-M 86-188, p.123 (1987).
- Shi 87b N. Shinohara, M. Magara, S. Usuda, S. Ichikawa, T. Suzuki, H. Iimura, Y. Kobayashi, T. Yamamoto, A. Yokoyama, Y. Nagame, Y. Hatsukawa, T. Horiguchi, M. Watasugi, S. Shibata, I. Fujiwara: JAERI TANDEM, LINAC & V.D.G. Annual Report 1986, JAERI-M 86-188, p.126 (1987).
- Shi 87c N. Shinohara: Private communication (1987).
- Shi 88 N. Shinohara, N. Kohno, T. Suzuki, S. Usuda: J. Radioanal. Nucl. Chem., 130 (1), to be published.
- Sik 68 T. Sikkeland, J. Maly, D.F. Lebeck: Phys. Rev., 169, 1000 (1968).
- Sil 69 R.J. Silva, T. Sikkeland, M. Nurmi, A. Ghiorso: J. Inorg. Nucl. Chem., 31, 3405 (1969).
- Sil 74 R.J. Silva, W.J. McDowell, O.L. Keller, Jr., J.R. Tarrant: Inorg. Chem., 13, 2233 (1974).
- Sis 72 D.H. Sission, V.A. Mode, D.O. Cambell: J. Chromatog., 66, 129 (1972).
- Ska 80 G. Skarnemark, P.O. Aronsson, K. Brodén, J. Rydberg, T. Björnstad, N. Kaffrell, E. Stender, N. Trautmann: Nucl. Instr. Methods, 171 323 (1980).
- Ska 83 G. Skarnemark, K. Brodén, Mao Yun, N. Kaffrell, N. Trantmann: Radiochimica Acta, 33, 97 (1983).
- Smi 56 H.L. Smith, D.C. Hoffmann: J. Inorg. Nucl. Chem., 3, 243, (1956).
- Spe 69 S. Specht, G. Höhle, W. Weinläder: Z. Anal. Chem., 244, 161 (1969).
- Sp1 76 V.I. Spitsyn, J.J. Katz (Eds.): "Chemistry of Transuranium Elements", Pergamon Press, Oxford (1976).
- Ste 65 D.C. Stewart, C.A.A. Bloquist, J.P. Faris: ANL-6999 (1965).
- Str 50 K. Street, Jr., G.T. Seaborg: J. Amer. Chem. Soc., 72, 279 (1950).
- Str 60 F.W.E. Strelow: Anal. Chem., 32, 1185 (1960).
- Str 65 F.W.E. Strelow, R. Rethemeyer, C.J.C. Bothma: Anal. Chem., 37, 106 (1965).
- Str 69 F.W.E. Strelow, C.R. Van Zyl, C.J.C. Bothma: Anal. Chem. Acta, 45, 81 (1969).
- Str 73 F.W.E. Strelow: "Ion Exchange and Solvent Extraction", Vol.5, Edited by J.A. Marinsky and Y. Marcus, Marcel Dekker, Inc., New York, p.121 (1973).
- Sue 86 K. Sueki, H. Yoshikawa, Y. Hatsukawa, H. Nakahara: UTRCN-S-12, p.26 (1986).
- Sur 57 J.P. Surls, G.R. Choppin: J. Inorg. Nucl. Chem., 4, 62 (1957).
- Suz 86 T. Suzaki, S. Okazaki, H. Okashita, I. Kobayashi, T. Suzuki, N. Kohno, M. Ohnuki, N. Shinohara, T. Sonobe, A. Ohno, K. Murakami, H. Umezawa, H. Tsuruta, S. Matsuura, Y. Asakura, S. Araya, T. Yamanouchi: J. Nucl. Sci. Technol., 23, 53 (1986).
- Tac 79 S. Tachimori: JAERI-M 8240 (1979), in Japanese.
- Tak 75 Y. Takata, Y. Arikawa: Bunseki Kagaku, 24, 762 (1975).
- Ter 61a F. Tera, J. Korkisch: Anal. Chim. Acta., 25, 222 (1961).
- Ter 61b F. Tera, J. Korkisch, F. Hecht: J. Inorg. Nucl. Chem., 16, 345, (1961).
- Tet 86 H. Tetzlaff, G. Herrman, N. Kaffrell, J.V. Kratz, J. Rogowski, N. Trautmann, M. Skolberg, G. Skarnemark, J. Alstad, M.M. Fowler, K.J. Moody, W. Brüchle, H. Gäggler, M. Schädel, K. Sümmerer: J. Less-Common Metals, 122, 441 (1986).
- The 80 M. Thein, S. Ballestra, A. Yamato, R. Fukai: Geochim. Cosmochim. Acta, 44, 1091 (1980).
- Tho 50 S.G. Thompson, K. Street, Jr., A. Ghiorso, G.T. Seaborg: Phys. Rev., 80, 790 (1950).
- Tho 54 S.G. Thompson, B.G. Harvey, G.R. Choppin, G.T. Seaborg: J. Amer. Chem. Soc., 76, 6229 (1954).
- Tür 88 A. Türler, F. Wegmüller, H.R. von Gunten, K.E. Gregorich, D. Lee, D.C. Hoffman, M.M. Fowler: Radiochimica Acta, 43, 149 (1988).
- Ume 73 H. Umezawa, S. Ichikawa, T. Suzuki, H. Okashita, H. Natsume: J. Nucl. Sci. Technol., 10, 489 (1973).
- Ume 74 H. Umezawa, S. Ichikawa, H. Natsume: JAERI-M 5785 (1974), in Japanese.
- Usu 81 S. Usuda, H. Umezawa: J. Inorg. Nucl. Chem., 43, 3081 (1981).

- Usu 86 S. Usuda, H. Yoshikawa, N. Shinohara: JAERI-M 86-067, 99 (1986).
- Usu 87a S. Usuda, N. Shinohara: JAERI-M 86-188 (1987).
- Usu 87b S. Usuda, N. Shinohara, H. Yoshikawa: J. Radioanal. Nucl. Chem., 109, 353 (1987).
- Usu 87c S. Usuda: J. Radioanal. Nucl. Chem., 111, 399 (1987).
- Usu 87d S. Usuda: J. Radioanal. Nucl. Chem., 111, 477 (1987).
- Usu 87e S. Usuda, N. Shinohara, H. Yoshikawa, S. Ichikawa, T. Suzuki: J. Radioanal. Nucl. Chem., 116, 125 (1987).
- Usu 87f S. Usuda, H. Yoshikawa, M. Magara, Y. Hatsukawa: J. Radioanal. Nucl. Chem., Letters, 117, 329 (1987).
- Usu 87g S. Usuda, M. Magara: J. Radioanal. Nucl. Chem., Letters, 119, 67 (1987).
- Usu 88a S. Usuda: J. Radioanal. Nucl. Chem., 123, 619 (1988).
- Usu 88b S. Usuda, N. Kohno: Sep. Sci. Technol., 23, 1119 (1988).
- Usu 88d S. Usuda, H. Umezawa: J. Radioanal. Nucl. Chem., Letters, 127, 437 (1988).
- Vio 62 V.E. Viola, Jr., T. Sikkeland: Phys. Rev., 128, 767 (1962).
- Vob 86 M. Vobecký: J. Radioanal. Nucl. Chem., Letters, 105, 335 (1986).
- Wal 71a C.W. Walter, J. Korkisch: Mikrochim. Acta, 1971, 81 (1971).
- Wal 71b C.W. Walter, J. Korkisch: Mikrochim. Acta, 1971, 137 (1971).
- Wal 71c C.W. Walter, J. Korkisch: Mikrochim. Acta, 1971, 158 (1971).
- Wal 71d C.W. Walter, J. Korkisch: Mikrochim. Acta, 1971, 181 (1971).
- Wan 87 S. Wang, P.B. Price, S.W. Barwick, K.J. Moody, E.K. Hulet: Phys. Rev. C, 36, 2717 (1987).
- War 56 M. Ward, G.A. Welch: J. Inorg. Nucl. Chem., 2, 395 (1956).
- Wea 68 B. Weaver: Anal. Chem., 40, 1894 (1968).
- Wil 61 D.H. Wilkins, G.E. Smith: Talanta, 8, 138 (1961).
- Wil 79 K.E. Williams, G.T. Seaborg: Phys. Rev. C, 19, 1794 (1979).
- Yak 83 N.G. Yakovlev, V.N. Kosyakov: Radiokhimiya, 25, 727 (1983).
- Yam 82 A. Yamato: J. Radioanal. Chem., 75, 265 (1982).
- Yan 86 S. Yanagihara, T. Suzuki: JAERI-M 85-208 (1986), in Japanese.
- Yao 81 Chen Yaozhong, Tan Bingmei, Wu Keming: J. Nucl. Radiochem., 3, 117 (1981), in Chinese.
- Yao 82 Chen Yaozhong, Wu Keming, Tan Bingmei: J. Nucl. Radiochem., 4, 177 (1982), in Chinese.
- Yao 87 Chen Yaozhong, Wei Liansheng, Fan Yuanfa, Jiang Fashun, Zhu Rongbao, Qiao Sengzhong, Lin Zhangji: J. Nucl. Radiochem., 9, 8 (1987), in Chinese.
- Yos 84 Y. Yoshizawa, T. Horiguchi, M. Yamada: "Chart of the nuclides", NEANDC(J)113/U, INDC(JPN)99/L (1984).
- Yos 87 H. Yoshikawa: Private communication (1987).
- Zva 81 I. Zvara: Pure & Appl. Chem., 53, 979 (1981).