

JAERI - M
88-172

RECOMMENDED PRACTICE FOR SMALL
PUNCH (SP) TESTING OF METALLIC
MATERIALS (DRAFT)

September 1988

Hideaki TAKAHASHI,* Tetsuo SHOJI,* Xinyuan MAO*
Yoshikazu HAMAGUCHI,** Toshihei MISAWA**
Masahiro SAITO,** Tatsuo OKU, Tsuneo KODAIRA
Kiyoshi FUKAYA, Hiroshi NISHI and Masahide SUZUKI

JAERI-Mレポートは、日本原子力研究所が不定期に公刊している研究報告書です。
入手の間合わせは、日本原子力研究所技術情報部情報資料課（〒319-11茨城県那珂郡東海村）
あて、お申しこしてください。なお、このほかに財団法人原子力弘済会資料センター（〒319-11茨城
県那珂郡東海村日本原子力研究所内）で複写による実費頒布をおこなっております。

JAERI-M reports are issued irregularly.

Inquiries about availability of the reports should be addressed to Information Division, Department
of Technical Information, Japan Atomic Energy Research Institute, Tokai-mura, Naka-gun,
Ibaraki-ken 319-11, Japan.

© Japan Atomic Energy Research Institute, 1988

編集兼発行	日本原子力研究所
印刷	日立高速印刷株式会社

Recommended Practice for Small Punch (SP)
Testing of Metallic Materials (Draft)

Hideaki TAKAHASHI^{*}, Tetsuo SHOJI^{*}, Xinyuan MAO^{*}
Yoshikazu HAMAGUCHI^{**}, Toshihei MISAWA^{**}, Masahiro SAITO^{**}
Tatsuo OKU, Tsuneo KODAIRA⁺, Kiyoshi FUKAYA, Hiroshi NISHI
and Masahide SUZUKI

(Received August 12, 1988)

This practice covers the determination of fracture toughness characteristics of metallic materials such as ductile to brittle transition temperature (SPDBTT) and elastic-plastic fracture toughness (J_{ICSP}) using miniature small punch (SP) specimens.

Three kinds of specimens with different shape; 10 by 10 by 0.5mm, 10 by 10 by 0.25mm and $\phi 3$ by 0.25mm, are selected as the standard SP specimens. Two types of fixture shall be respectively used for the $\square 10$ and $\phi 3$ specimens. The relationship between load and deflection during buldge tests shall be recorded from low to high temperatures. Following two parameters in relation to fracture toughness are obtained from analyses of load-deflection curves: (1) The SP energy is calculated from the area surrounded with load-deflection curves, which corresponds to the total energy consumed up to the fracture. (2) The equivalent fracture strain ($\bar{\epsilon}_{qf}$) is calculated from the maximum deflection at fracture (δ^*). The SPDBTT can be derived from temperature dependence of SP energy, and the J_{ICSP} can be estimated from the rational correlation curve between $\bar{\epsilon}_{qf}$ and J_{IC} .

Keywords: Miniature Specimen, Small Punch Test, Buldge Test, Plain Strain, Elastic-plastic, Fracture Toughness, Transition Temperature, DBTT, TEM Disk, Fracture, Energy, Strain

+ Office of Planning

* Tohoku University

** Muroran Institute of Technology

金属材料の小型パンチ (S P) 試験方法 (案)

日本原子力研究所東海研究所高温工学部

高橋 秀明*・庄子 哲雄*・毛 星原*・浜口 由和**
三沢 俊平**・斉藤 雅弘**・奥 達雄・古平 恒夫+
深谷 清・西 宏・鈴木 雅秀

(1988年8月12日受理)

本試験方法は、微小な小型パンチ (S P) 試験所を用いて、金属材料の破壊靱性に関連する特性すなわち遷移温度 (S P D B T T) 及び弾塑性破壊靱性 (J_{ICSP}) を求めるためのものである。

標準の S P 試験片の大きさは、 $10 \times 10 \times 0.5$ mm, $10 \times 10 \times 0.25$ mm 及び 3ϕ mm \times 0.25 mm の3種類とし、治具として10 mm及び ϕ 3 mm用の2種類を用いる。S P 試験は、いわゆる深絞り (バルジ) 試験であり、遷移温度領域を含む低温から高温までの種々の温度で行うと共に、それぞれの荷重-変位曲線を取得することが必要である。この荷重-変位曲線から破壊靱性に関する2種類のパラメータの値を算出することができる。(1)荷重-変位曲線で描かれる面積、すなわち、破壊までに費された全エネルギー (以下S P エネルギーと呼ぶ) を求め、その試験温度依存性から遷移温度 (S P D B T T) を測定する。(2)破壊時の最大変位 (δ^*) から、破壊等価ひずみ (ϵ_{qf}) を算出し、 J_{IC} 値に対応する J_{ICSP} を算出する。

東海研究所：〒319-11 茨城県那珂郡東海村白方字白根2-4

+ 企画室

* 東北大学

** 室蘭工業大学

Contents

1. Introduction	1
1.1 Scop	1
1.2 Summary of Method	1
1.3 Significance and Use	1
2. Terminology	2
2.1 Definition	2
2.2 Symbol	3
3. Test Method	4
3.1 Apparatus	4
3.2 Measuring Items	5
3.3 Procedure	5
4. Calculation and Interpretation of Results	6
4.1 Evaluation of SP Energy and SPDBTT	6
4.2 Evaluation of Equivalent Fracture Strain $\bar{\epsilon}_{qf}$ and Estimation of J_{ICSP}	6
5. Report	7
5.1 Items to be reported	7
5.2 Items to be optionally reported	7
6. Afterword	8
Acknowledgement	8
References	8
Appendix A Deformation and Fracture Processes in the SP Test	16
Appendix B β Values for Ferritic and Austenitic Steels	19

目 次

1. 序	1
1.1 目 的	1
1.2 試験方法の概要	1
1.3 意 及び適用範囲	1
2. 用 語	2
2.1 定 義	2
2.2 記 号	3
3. 試験方法	4
3.1 試験装置	4
3.2 測定項目	5
3.3 試験手順	5
4. 計算と結果の記述	6
4.1 SPエネルギー及びSPDBTTの評価	6
4.2 破壊等価ひずみ ϵ_{qf} の評価及び J_{ICSP} の算出	6
5. 警 告	7
5.1 報告事項	7
5.2 報告することが望ましい事項	7
6. 結 び	8
謝 辞	8
参考文献	8
付録A SP試験における変形及び破壊過程	16
付録B フェライト及びオーステナイト鋼用 β 値	19

1. Introduction

1.1 Scope

This practice covers the determination of fracture toughness characteristics of metallic materials such as ductile to brittle transition temperature (SPDBTT) and elastic-plastic fracture toughness (J_{ICSP}) using miniature small punch (SP) specimens.

1.2 Summary of Method

Figure 1 shows the schematic illustration of specimens and set up for the SP testing. Three kinds of specimen are used as the standard ones, which have the dimension of 10 by 10 by 0.5mm, 10 by 10 by 0.25mm and $\phi 3$ by 0.25mm. Two types of fixture shall be respectively used for the 10[□] and $\phi 3$ specimens. The relationship between load and deflection during bulging shall be recorded from low to high temperatures. The following two parameters characterizing fracture toughness can be obtained from the load-deflection record: (1) The SP energy is calculated from the area under load-deflection record, which means the energy consumed up to the fracture. (2) The equivalent fracture strain ($\bar{\epsilon}_{qf}$) is calculated from the maximum deflection at fracture (δ^*). The SPDBTT can be derived from several data sets between SP energy and testing temperature, and the J_{ICSP} can be estimated from the rational correlation curve between $\bar{\epsilon}_{qf}$ and J_{IC} .

1.3 Significance and Use

1.3.1 Significance

- 1) An impact test with Charpy V notch (CVN) type specimens is currently used to evaluate the DBTT of structural materials for practical applications, such as the material selection and/or surveillance test of a light water reactor (LWR) pressure vessel and so on. On the other hand, standardization for test methods with small specimens for above purpose have been strongly required for structural change and/or save of testing cost.
- 2) Plane-strain fracture toughness, K_{IC} and elastic-plastic fracture toughness, J_{IC} are required to satisfy the valid conditions against the specimen size. In accordance with these requirement, the minimum size seems to be the compact specimen with about 10 by 25 by 25mm or

three point bend specimen with 10 by 10 by 55mm like a CVN impact type. The present SP test method is completely different from those procedures mentioned above, and it is based on constraining a thin plate or disk at the multiaxial stress state. A fracture toughness can be estimated by this SP test using specimens, one is a rectangular shape, 0.5mm (or 0.25) in thickness, 10mm in length, and the other is 3mm disk with 0.25mm in thickness which corresponds to so-called, TEM disk, used in an electron microscope.

1.3.2 Use

This method can be used in the followings.

- 1) Toughness evaluation and design for materials with inhomogeneous structures.
- 2) Experiments on radiation damage such as neutron or surveillance tests for nuclear structural materials.
- 3) Evaluation for the degradation of material performances after long term operation in an actual plant.

1.3.3 Application

This method is used to obtain the following fracture toughness characteristics using a rational evaluation curve.

- 1) Ductile to brittle transition temperature obtained by the CVN test (CvDBTT).
- 2) Elastic-plastic fracture toughness (J_{IC}).

2. Terminology

2.1 Definition

- (1) Ductile-Brittle Transition Temperature, DBTT: This denotes a temperature that the toughness value suddenly decreases in the CVN or other toughness tests. DBTT is determined by the data set between testing temperature and absorbed energy, lateral expansion or percentage of shear fracture. CvDBTT means the DBTT obtained by the CVN test.
- (2) Elastic-Plastic Fracture Toughness, J_{IC} : The fracture resistance at the onset of mode I type ductile tearing under plain strain condition.
- (3) Plane-Strain Fracture Toughness, K_{IC} : The crack-extension resistance

three point bend specimen with 10 by 10 by 55mm like a CVN impact type. The present SP test method is completely different from those procedures mentioned above, and it is based on constraining a thin plate or disk at the multiaxial stress state. A fracture toughness can be estimated by this SP test using specimens, one is a rectangular shape, 0.5mm (or 0.25) in thickness, 10mm in length, and the other is 3mm disk with 0.25mm in thickness which corresponds to so-called, TEM disk, used in an electron microscope.

1.3.2 Use

This method can be used in the followings.

- 1) Toughness evaluation and design for materials with inhomogeneous structures.
- 2) Experiments on radiation damage such as neutron or surveillance tests for nuclear structural materials.
- 3) Evaluation for the degradation of material performances after long term operation in an actual plant.

1.3.3 Application

This method is used to obtain the following fracture toughness characteristics using a rational evaluation curve.

- 1) Ductile to brittle transition temperature obtained by the CVN test (CvDBTT).
- 2) Elastic-plastic fracture toughness (J_{IC}).

2. Terminology

2.1 Definition

- (1) Ductile-Brittle Transition Temperature, DBTT: This denotes a temperature that the toughness value suddenly decreases in the CVN or other toughness tests. DBTT is determined by the data set between testing temperature and absorbed energy, lateral expansion or percentage of shear fracture. CvDBTT means the DBTT obtained by the CVN test.
- (2) Elastic-Plastic Fracture Toughness, J_{IC} : The fracture resistance at the onset of mode I type ductile tearing under plain strain condition.
- (3) Plane-Strain Fracture Toughness, K_{IC} : The crack-extension resistance

under condition of crack-tip plane strain.

- (4) TEM disk: a specimen used for the observation of transmission electron microscope (TEM), which generally has the size of $\phi 3.0$ by about 0.25mm.
- (5) Small Punch (SP) Test: a bulge type test based on this procedure.
- (6) SP Energy: A total energy spent up to fracture in the SP test, and this energy is obtained by the area surrounded under load-deflection curves.
- (7) SPDBTT: The transition temperature obtained from the transition curve in the SP test. SPDBTT is the temperature at the SP energy level of $(SP_{\max} + SP_{\min})/2$, where SP_{\max} and SP_{\min} are the SP energy at upper and lower shelves respectively.
- (8) Maximum Deflection, δ^* : A deflection measured at the sudden load drop point (P_F) beyond the maximum load (P_{\max}) in the load-deflection curve of the SP test.
- (9) Equivalent Fracture Strain, $\bar{\epsilon}_{qf}$: The strain defined by the following equation.

$$\bar{\epsilon}_{qf} = \ln (t_o / t^*)$$
 where t_o is the initial thickness and t^* is the minimum thickness of broken SP specimen.
- (10) J_{ICSP} : J_{IC} value estimated by the SP test.

2.2 Symbol

- (1) SP_{\max} [F]: Upper shelf SP energy
- (2) SP_{\min} [F]: Lower shelf SP energy
- (3) P_{\max} [F]: Maximum load
- (4) P_F [F]: Fracture Load
- (5) t_o [L]: Initial thickness of SP specimen
- (6) t^* [L]: Minimum thickness of broken SP specimen
- (7) δ^* [L]: Maximum deflection at fracture
- (8) $\bar{\epsilon}_{qf}$ [L/L]: Equivalent fracture strain
- (9) J_{IC} [FL⁻¹]: Elastic-plastic fracture toughness

3. Test Method

3.1 Apparatus

3.1.1 Testing Machine

The testing machine shall have a capabilities of the compressive loading and the automatic recording system for the load. It is also desirable for the testing machine that the loading and unloading can be done at a given deflection level. The load shall be measured with the accuracy within 1% for the maximum loading.

3.1.2 Setup

The recommended set up for the SP test are respectively shown in Fig. 2 for the \square 10mm specimen and Fig. 3 for the ϕ 3 specimen. Two types of steel ball with ϕ 2.4mm (3/22 inch) and ϕ 1.0mm are used for the bulging, and these balls shall have the hardness of HRC62 to 67. The lower die contacting with SP specimens is recommended to have a surface finished finely, for example $R_{\max} = 3.2$ S. To make holes in the lower die for specimen removal are required for the smooth handling of the SP specimen.

3.1.3 Deflection-Measuring Device

The deflection is the cross-head displacement in principle. It is also recommended to use the dial gage attached to the cross-head of the testing machine. An accuracy within 1% of working range of the device is required.

3.1.4 Heating and Cooling Devices

The heating and cooling devices shall have the capability of the temperature controll within $\pm 2^{\circ}\text{C}$ for the target value during the test. For the low temperature test, liquid nitrogen or the mixture of liquid nitrogen and dry ice is recommended as the coolant. It is necessary to cool down SP specimens without direct contact to the coolant. For the high temperature test, sheathed type or ribbon type of heaters are usually used. It is required that the SP specimen contact with an inert gaseous environment during both low and high temperature testing.

3.1.5 Recorder

The automatic recorders for the load-deflection curve and temperature shall have the enough stability and quick response for the signal during

testing.

3.1.6 Specimens

Table 1 shows the shapes of SP specimens. All these specimens shall have the thickness within a accuracy at five measuring points. Each shape of the SP specimens has the different evaluation purposes. The SP specimen surface contacting with lower die is recommended to finish by mechanical or electrical polishing and the surface in the bulging side should be finished using the emery paper of #1200.

3.2 Measuring Items

The load, deflection and testing temperature shall be automatically recorded during the SP test.

3.3 Procedure

3.3.1 Fixing of Specimens

The SP specimen be fixed at the center axis of the setup and symmetrically deformed. The preliminary test is recommended to do using several specimens before the test. The specimen shall be diagonally and equally clamped using four bolts. The final clamping torque range should be 0.5 to 1.0 N·m.

3.3.2 Testing Temperature

The temperature control and record shall be done in accordance with 3.1.4 and 3.1.5 and maintained within $\pm 2^\circ\text{C}$ during testing. Thirty minutes is required for heating or cooling uniformly to the target temperature.

3.3.3 Loading of Specimens

The SP specimen shall be loaded at the cross-head speed of 0.1 to 1.0 mm/min, and 0.5 mm/min is a standard.

3.3.4 Load-Deflection Record

The load-deflection curve shall be automatically recorded during the SP test. The out-put sensitivity of the recorder should be adjusted to get the gradient of 45° to 80° at initial elastic part of the load-deflection curve and to measure the load within the accuracy of 1% for the maximum load. The

maximum load and deflection depend on materials, but Table 2 is used for the reference purpose.

4. Calculation and Interpretation of Results

4.1 Evaluation of SP Energy and SPDBTT

4.1.1 Evaluation of SP Energy from Load-Deflection Record

Conduct the SP test at several temperatures and record the load-deflection relationship. Typical example is shown in Fig. 4, and it is known that a low energy fracture occurs at low temperature side and the fracture energy increases with the elevation of test temperature. The SP energy is obtained from the area under load-deflection record using the roller planimeter or numerical integration.

4.1.2 Determination of SPDBTT

Measure the SP energy in accordance with 4.1.1 and plot it against the testing temperature. Typical example is shown in Fig. 5. The SPDBTT is defined by the temperature at the energy level of $(SP_{max} + SP_{min})/2$, where SP_{max} and SP_{min} are energies at the upper and lower shelves.

4.2 Evaluation of Equivalent Fracture Strain $\bar{\epsilon}_{qf}$ and Estimation of J_{ICSP} (Upper Shelf Region)

4.2.1 Determination of Maximum Deflection at Fracture δ^*

The δ^* is defined by the sudden load drop (P_F) beyond the maximum load (P_{max}) in the load-deflection record in the SP test.

4.2.2 Calculation of $\bar{\epsilon}_{qf}$ and Estimation of J_{ICSP}

The $\bar{\epsilon}_{qf}$ is calculated by the following rational equation.

$$\bar{\epsilon}_{qf} = \ln (t_o/t^*) = \beta (\delta^*/t_o)^2 \dots\dots\dots (1)$$

where, t_o is initial specimen thickness, t^* is minimum thickness of broken specimen and β is the constant. β is 0.09 for ferritic steels as shown in Fig. 7 and 0.043 for austenitic steels as shown in Fig. B-1. The $\bar{\epsilon}_{qf}$ should be calculated using δ^* , but it is also possible using equation (1) after the measurement of t^* . The J_{IC} can be estimated by the rational correlation

maximum load and deflection depend on materials, but Table 2 is used for the reference purpose.

4. Calculation and Interpretation of Results

4.1 Evaluation of SP Energy and SPDBTT

4.1.1 Evaluation of SP Energy from Load-Deflection Record

Conduct the SP test at several temperatures and record the load-deflection relationship. Typical example is shown in Fig. 4, and it is known that a low energy fracture occurs at low temperature side and the fracture energy increases with the elevation of test temperature. The SP energy is obtained from the area under load-deflection record using the roller planimeter or numerical integration.

4.1.2 Determination of SPDBTT

Measure the SP energy in accordance with 4.1.1 and plot it against the testing temperature. Typical example is shown in Fig. 5. The SPDBTT is defined by the temperature at the energy level of $(SP_{\max} + SP_{\min})/2$, where SP_{\max} and SP_{\min} are energies at the upper and lower shelves.

4.2 Evaluation of Equivalent Fracture Strain $\bar{\epsilon}_{\text{qf}}$ and Estimation of J_{ICSP} (Upper Shelf Region)

4.2.1 Determination of Maximum Deflection at Fracture δ^*

The δ^* is defined by the sudden load drop (P_{F}) beyond the maximum load (P_{\max}) in the load-deflection record in the SP test.

4.2.2 Calculation of $\bar{\epsilon}_{\text{qf}}$ and Estimation of J_{ICSP}

The $\bar{\epsilon}_{\text{qf}}$ is calculated by the following rational equation.

$$\bar{\epsilon}_{\text{qf}} = \ln(t_0/t^*) = \beta (\delta^*/t_0)^2 \dots\dots\dots (1)$$

where, t_0 is initial specimen thickness, t^* is minimum thickness of broken specimen and β is the constant. β is 0.09 for ferritic steels as shown in Fig. 7 and 0.043 for austenitic steels as shown in Fig. B-1. The $\bar{\epsilon}_{\text{qf}}$ should be calculated using δ^* , but it is also possible using equation (1) after the measurement of t^* . The J_{IC} can be estimated by the rational correlation

between $\bar{\epsilon}_{qf}$ and J_{IC} as shown in Fig. 8.

5. Report

5.1 Items to be reported

The test report shall contain the followings.

- (1) Material, position and orientation of extracted specimen,
- (2) Specimen thickness, t_0 (five measured values and its average),
- (3) Diameter or dimension of specimen,
- (4) Testing temperature, and
- (5) Loading rate.

In addition, the following data shall be stored for the evaluation of SP energy and SPDBTT.

- (1) SP_{energy} ,
- (2) SP_{max} ,
- (3) SP_{min} ,
- (4) SPDBTT.

For the evaluation of $\bar{\epsilon}_{qf}$ and estimation of J_{ICSP} , the following items should be contained in each test.

- (1) δ^* ,
- (2) $\bar{\epsilon}_{qf}$,
- (3) J_{ICSP} ,

5.2 Items to be optionally reported

- (1) Details of specimen preparation,
- (2) Load-deflection record,
- (3) Fracture surface,
 - (a) Preparation of fracture surface,
 - (b) Observation procedure and magnification,
 - (c) Fracture appearance,
- (4) t^*

between $\bar{\epsilon}_{qf}$ and J_{IC} as shown in Fig. 8.

5. Report

5.1 Items to be reported

The test report shall contain the followings.

- (1) Material, position and orientation of extracted specimen,
- (2) Specimen thickness, t_0 (five measured values and its average),
- (3) Diameter or dimension of specimen,
- (4) Testing temperature, and
- (5) Loading rate.

In addition, the following data shall be stored for the evaluation of SP energy and SPDBTT.

- (1) SP_{energy},
- (2) SP_{max},
- (3) SP_{min},
- (4) SPDBTT.

For the evaluation of $\bar{\epsilon}_{qf}$ and estimation of J_{ICSP} , the following items should be contained in each test.

- (1) δ^* ,
- (2) $\bar{\epsilon}_{qf}$,
- (3) J_{ICSP} ,

5.2 Items to be optionally reported

- (1) Details of specimen preparation,
- (2) Load-deflection record,
- (3) Fracture surface,
 - (a) Preparation of fracture surface,
 - (b) Observation procedure and magnification,
 - (c) Fracture appearance,
- (4) t^*

6. Afterword

This report is one of the results of the cooperative research among Tohoku University, Muroran Institute of Technology and Japan Atomic Energy Research Institute.

Acknowledgement

The authors want to express their gratitude to Drs. T. Yasuno and T. Kondo, Japan Atomic Energy Research Institute, for encouraging and supporting this work.

References

- 1) X. Y. Mao et al., ASTM J. Testing and Evaluation, vol. 15 (1987) 30
- 2) X. Y. Mao and H. Takahashi, J. of Nucl. Materials, 150 (1987) 42
- 3) T. Misawa et al., J. of Nucl. Materia-s, 150 (1987)194

6. Afterword

This report is one of the results of the cooperative research among Tohoku University, Muroran Institute of Technology and Japan Atomic Energy Research Institute.

Acknowledgement

The authors want to express their gratitude to Drs. T. Yasuno and T. Kondo, Japan Atomic Energy Research Institute, for encouraging and supporting this work.

References

- 1) X. Y. Mao et al., ASTM J. Testing and Evaluation, vol. 15 (1987) 30
- 2) X. Y. Mao and H. Takahashi, J. of Nucl. Materials, 150 (1987) 42
- 3) T. Misawa et al., J. of Nucl. Materia-s, 150 (1987)194

6. Afterword

This report is one of the results of the cooperative research among Tohoku University, Muroran Institute of Technology and Japan Atomic Energy Research Institute.

Acknowledgement

The authors want to express their gratitude to Drs. T. Yasuno and T. Kondo, Japan Atomic Energy Research Institute, for encouraging and supporting this work.

References

- 1) X. Y. Mao et al., ASTM J. Testing and Evaluation, vol. 15 (1987) 30
- 2) X. Y. Mao and H. Takahashi, J. of Nucl. Materials, 150 (1987) 42
- 3) T. Misawa et al., J. of Nucl. Material-s, 150 (1987)194

Table 1 Standard SP specimens.

SP Specimen	Thickness, t_0 (mm)	Subjects
10 x 10 (10 [□])	0.5 ± 0.05	<ul style="list-style-type: none"> • $\bar{\epsilon}_{qf}$ • SPDBTT (Ferritic Steel)
	0.25 ± 0.03	<ul style="list-style-type: none"> • SPDBTT (Ferritic Steel) • Low Temperature SP Energy (ex. Austenitic Steel)
φ3.0	0.25 ± 0.013	<ul style="list-style-type: none"> • $\bar{\epsilon}_{qf}$, • SPDBTT • Low Temperature SP Energy

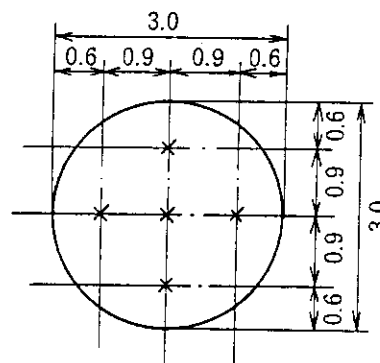
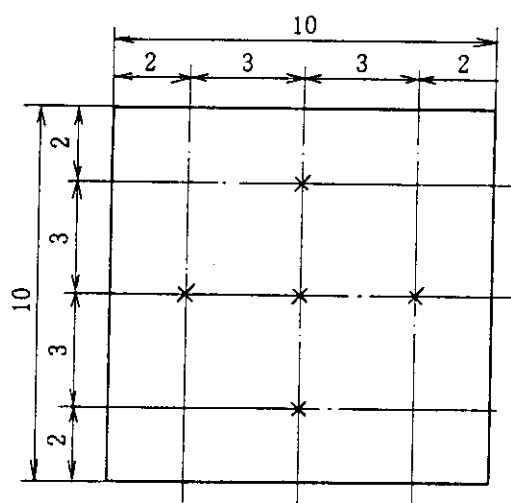

Measuring Points (mm)

Table 2 Aimed values of load and deflection in SP test.

	10 [□] Specimen		φ3 Specimen	
	Load (kN)	Deflection(mm)	Load (kN)	Deflection(mm)
Ferritic Steel	~ 2	~ 2	~ 0.5	~ 0.8
Austenitic Steel	~ 2	~ 2	~ 0.4	~ 0.8

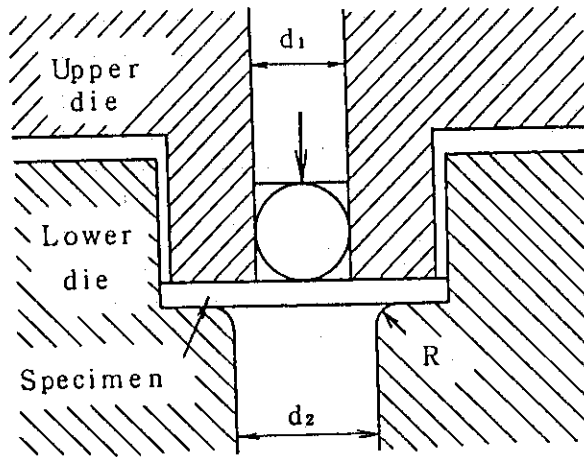

	Small (10×10)	TEM disk (φ3)
t ₀	0.50 0.25	0.25
d ₁	2.4	1.0
d ₂	4.0	1.5
R	0.2	0.2
Steel ball	φ2.4	φ1

: mm

Small Punch Test
(Bulge Test)

$$d_2 \geq d_1 + 2t_0$$

Fig. 1 Schematic drawing of setup for SP test.

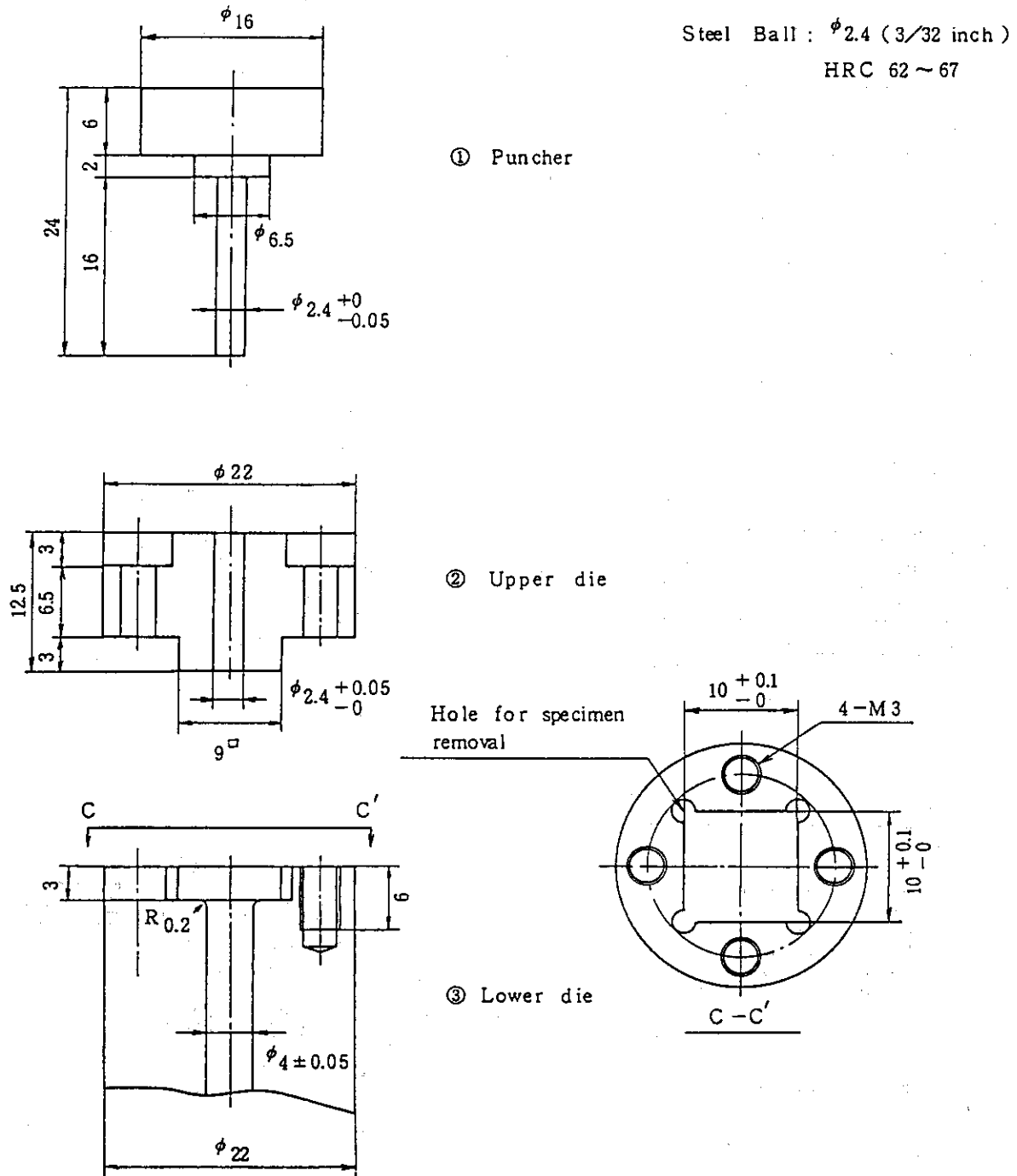
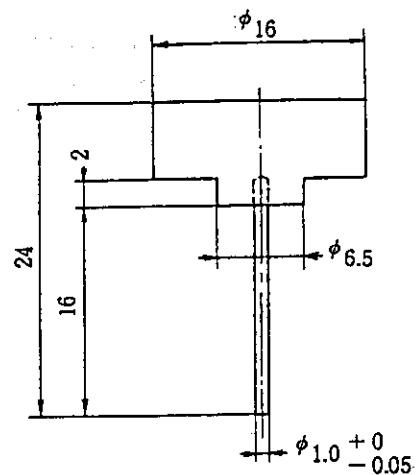
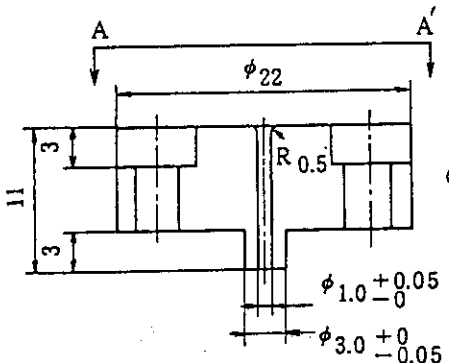

Fig. 2 Detail drawing of Setup for 10 specimens.



① Puncher

Steel Ball : $\phi 1.0$
HRC 62~67



② Upper die

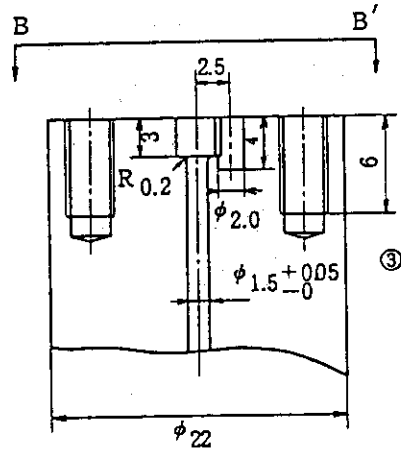
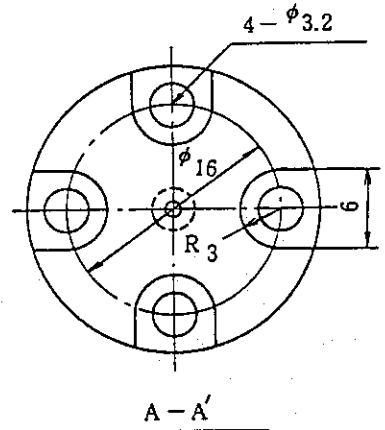

③ Lower die

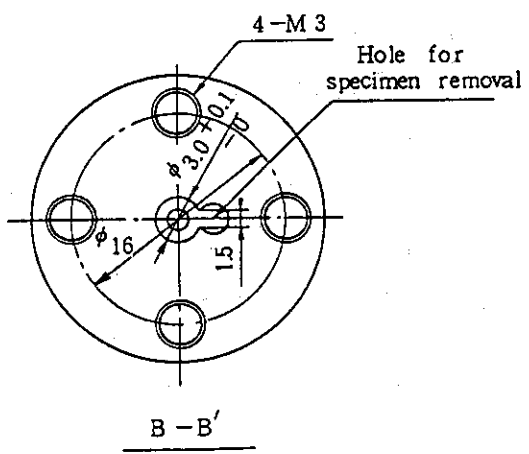

Fig. 3 Detail drawing of setup for 3 specimens.

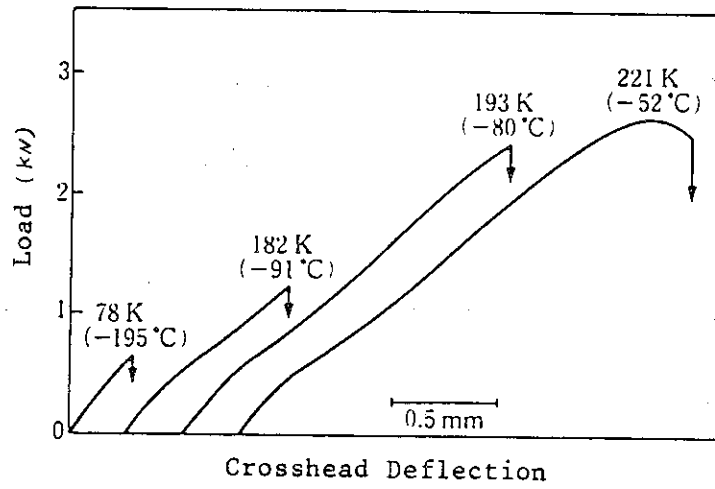

Fig. 4 Load-deflection records at several temperatures. (J. Kameda et al.)

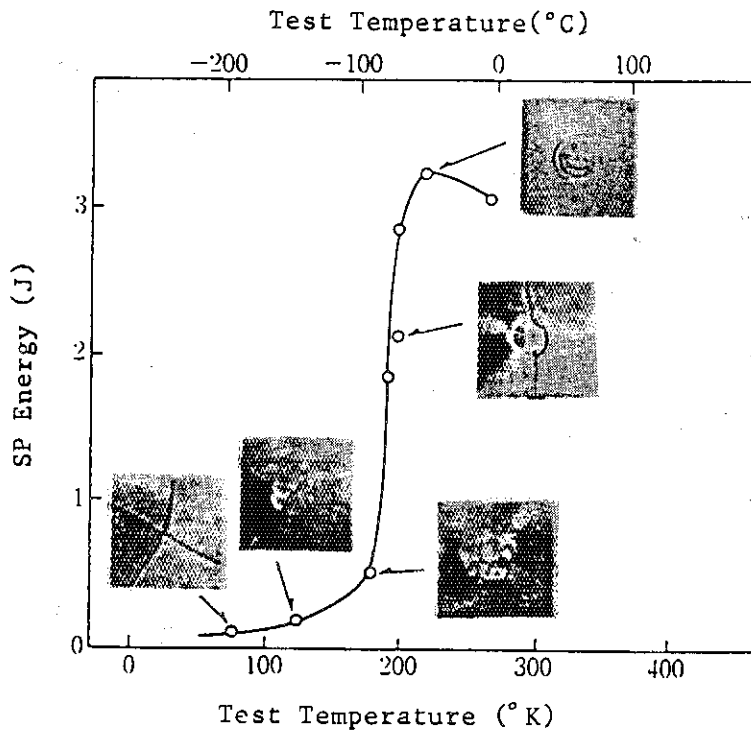

Fig. 5 Transition curve of SP energy and related fracture appearance. (J. Kameda et al.)

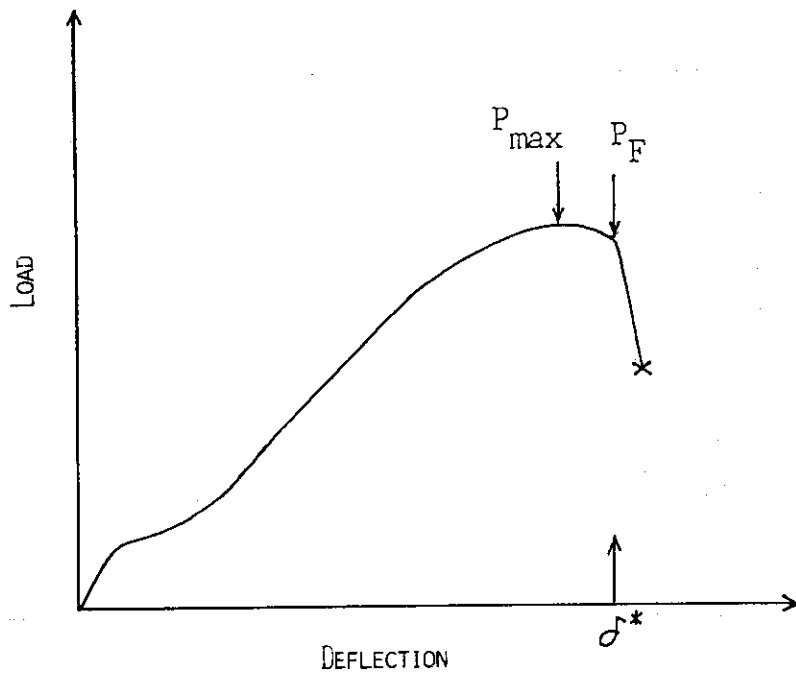

Fig. 6 Determination of δ^* in load-deflection record.

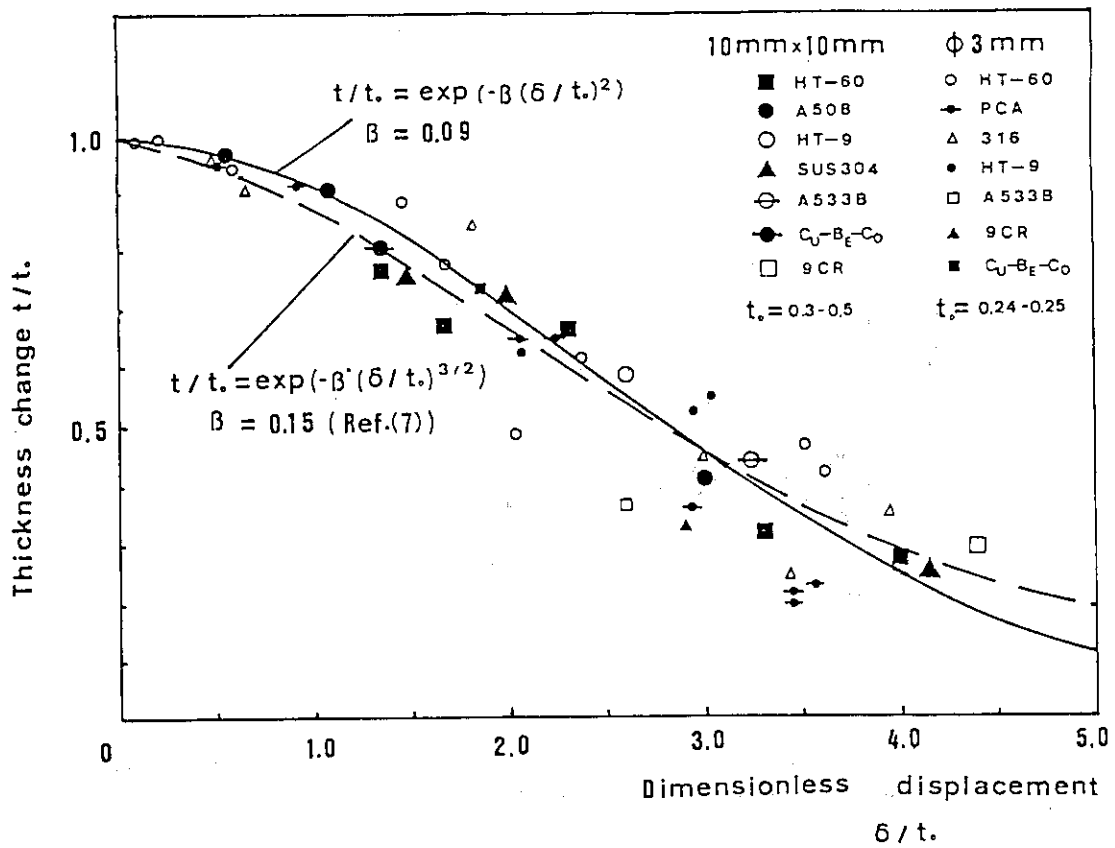

Fig. 7 Relation between t/t_0 and δ/t in SP test.

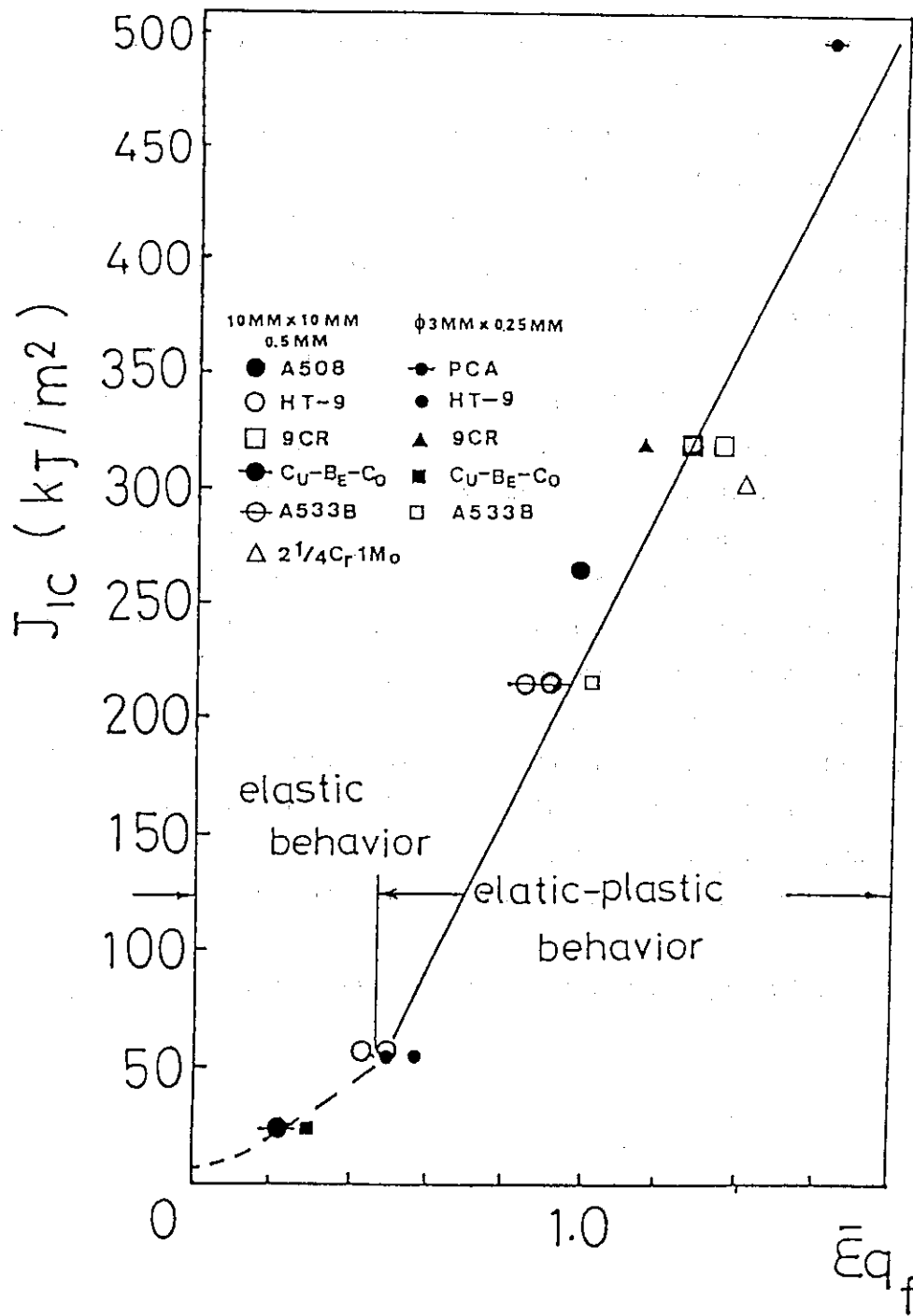

Fig. 8 Relation between $\bar{\epsilon}_{qf}$ and J_{IC} .

Appendix A Deformation and Fracture Processes in the SP Test

It is very important to know the fracture point in the SP test for the determination of SP energy or $\bar{\epsilon}_{qf}$.

For the low temperature, the fracture usually occurs at the maximum load (P_{\max}) as shown in Fig. 4 and the onset of fracture is very clear. On the other hands, there are a few points on the fracture for the elastic-plastic behavior. In this practice, P_F is defined as a fracture point and this reason will be shown in the following.

Figure A-1 shows microfractographs at P_{\max} and P_F and the load-deflection curve of 10^{\square} specimen of A533B cl.1 steel at room temperature as a typical example. Several micro cracks are found at point A (P_{\max}) and the crack opening begins at point B (P_F). Fractographic observations are performed at another point on the load-deflection curve concerning not only A533B steel but also other materials such as $2^{1/4}\text{Cr-1Mo}$ steel. Metallographic observation is also done in the mid-section of broken specimens. From these results, the deformation and fracture processes in the SP test are considered to be as follow for the elastic-plastic behavior as shown in Fig. A-2.

- ① Plastic membrane stretching after plastic deformation,
- ② Micro cracks yield in the tension side of SP specimen at P_{\max} , and
- ③ Microcraks grow to main crack,
- ④ Main cracks penetrate through thickness and the sudden load drop occurs at P_F .

Therefore, it is known that the minimum thickness of specimens is established at P_F i.e. δ^* .

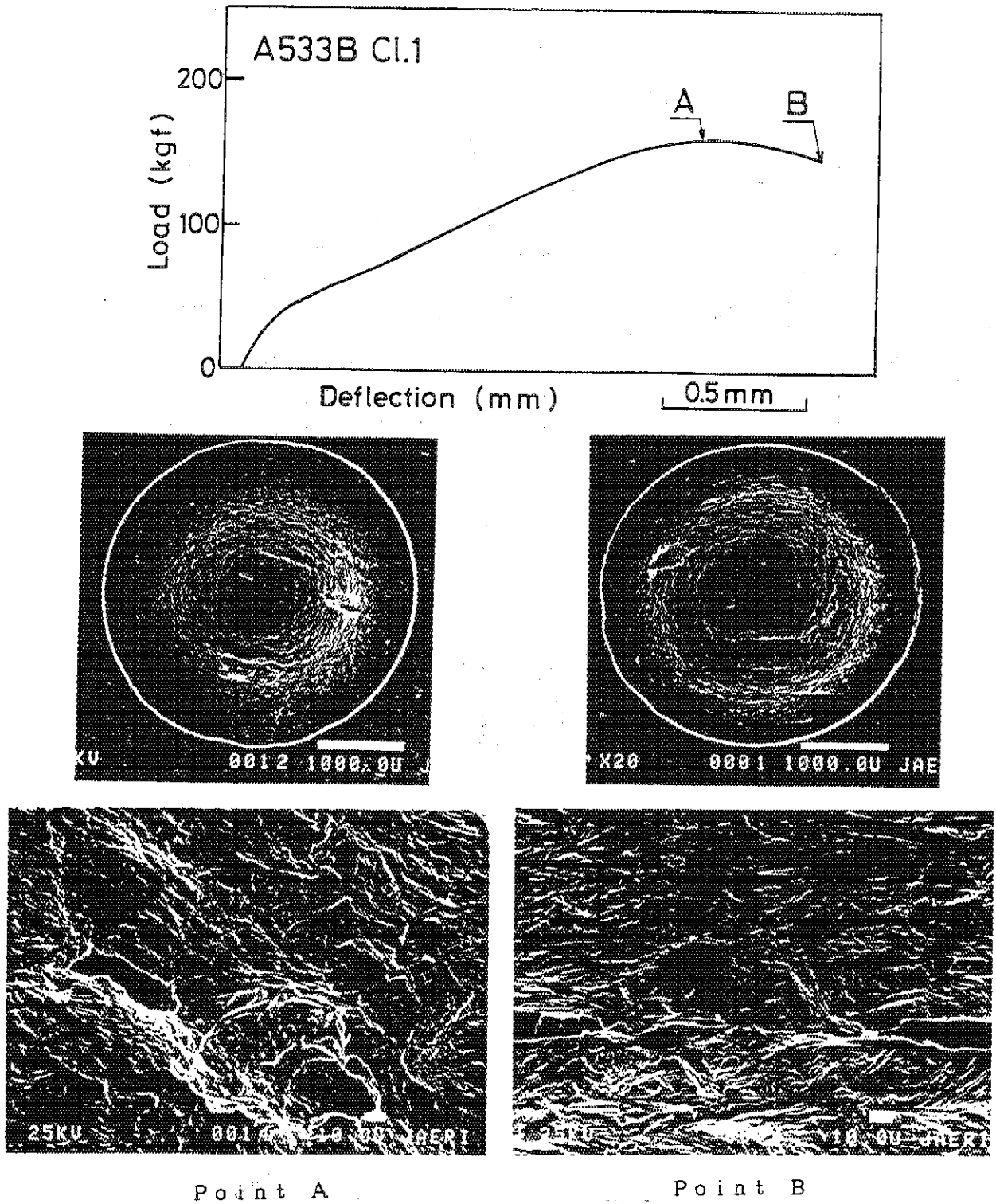

Fig. A-1 Load-deflection curve and microfractographs in SP test.

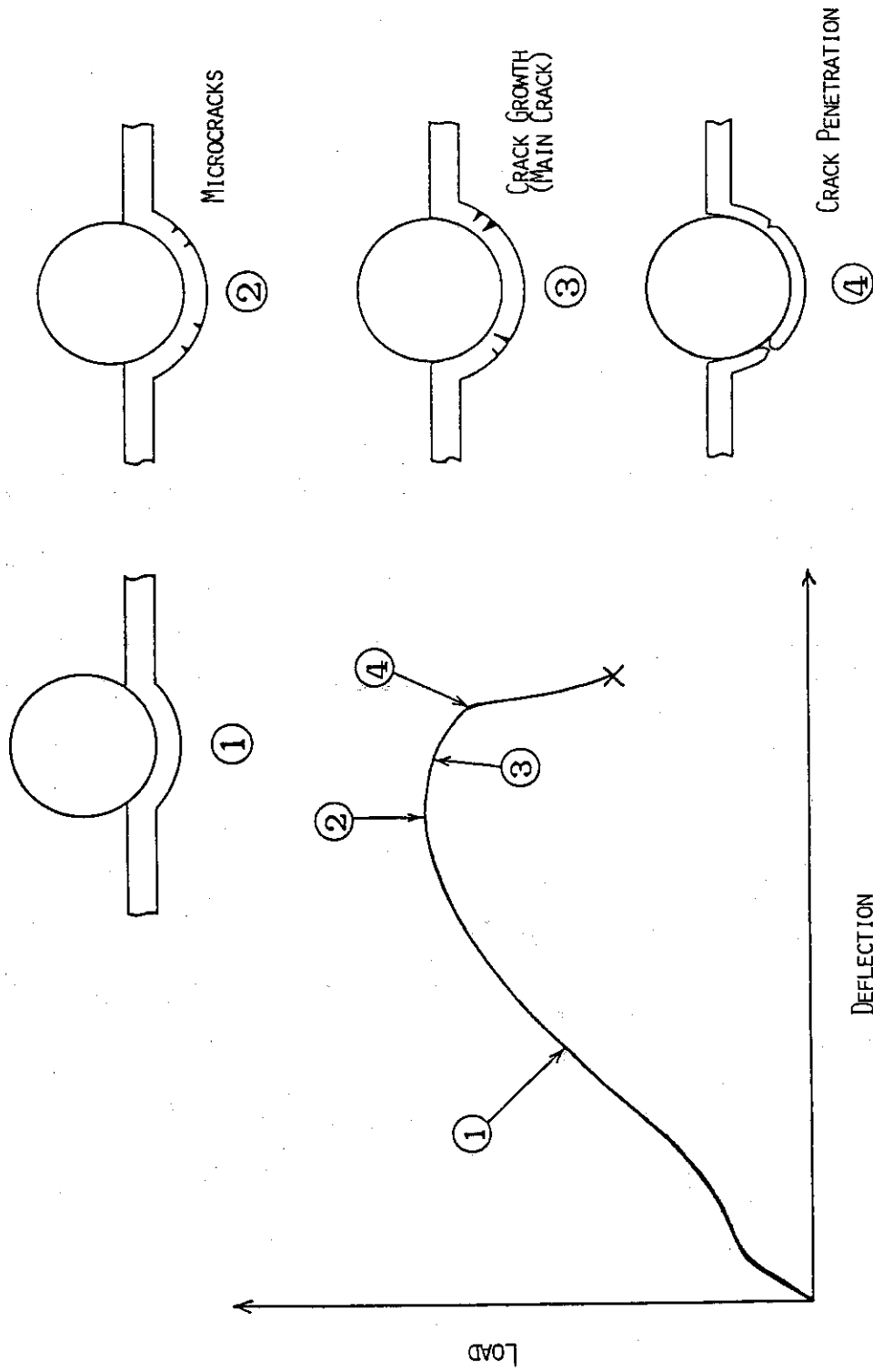

Fig. A-2 Schematic illustration of deformation and fracture processes in SP test.

Appendix B β Values for Ferritic and Austenitic Steels

In principle, β is dependent on materials as previously described in 4.2.2. For ferritic steels, β is 0.09 as shown in Fig. 7. On the other hands, β of 0.043 is reasonable for stable austenitic steels as shown in Fig. B-2. Unstable austenitic steels such as 304 SS, which have the tendency of transformation to martensite structure due to plastic deformation, might have another value as shown in Fig. B-1.

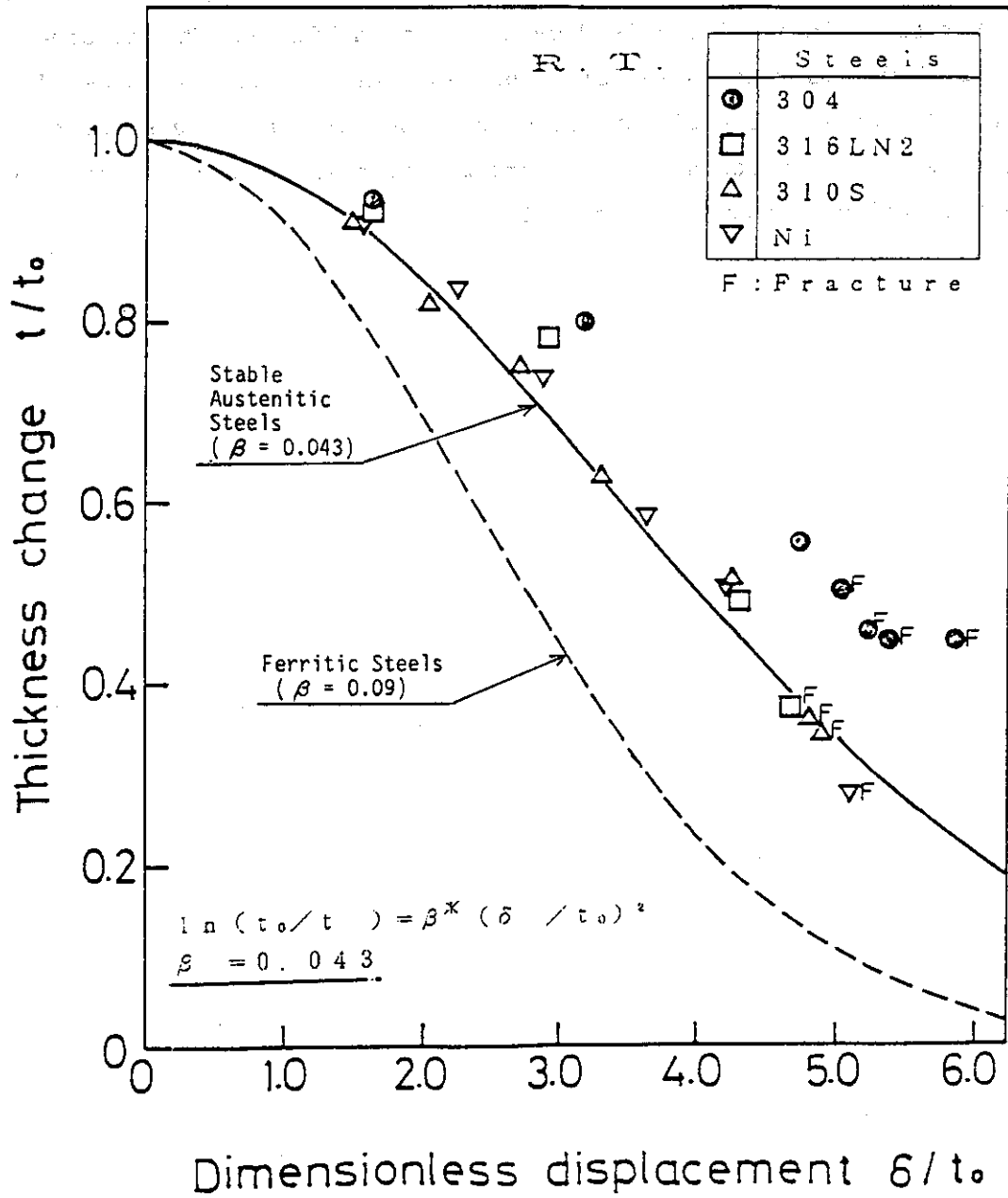

Fig.B-1 Relation between thickness change and dimensionless displacement.
(T. Misawa et al.)