

JAERI - M
90-028

JOINT OPERATION OF TSTA UNDER THE
COLLABORATION BETWEEN JAERI AND DOE-LANL
—AN INTEGRATED LOOP OPERATION WITH 100-G TRITIUM IN JULY 1988—

February 1990

Kenji OKUNO, Mikio ENOEDA, Takafumi IDE^{*1}
Hiroshi FUKUI,^{*2} Hiroshi YOSHIDA, Yuji NARUSE
J.L. ANDERSON,^{*3} J.R. BARTLIT,^{*3} R.H. SHERMAN^{*3}
R.V. CARLSON,^{*3} D.O. COFFIN,^{*3} J.E. NASISE^{*3}
and R.S. WILLIMS^{*3}

JAERI-M レポートは、日本原子力研究所が不定期に公刊している研究報告書です。
入手の問合わせは、日本原子力研究所技術情報部情報資料課（〒319-11 茨城県那珂郡東海村）
あて、お申しこしてください。なお、このほかに財団法人原子力弘済会資料センター（〒319-11 茨城
県那珂郡東海村日本原子力研究所内）で複写による実費頒布をおこなっております。

JAERI-M reports are issued irregularly.
Inquiries about availability of the reports should be addressed to Information Division, Department
of Technical Information, Japan Atomic Energy Research Institute, Tokai-mura, Naka-gun,
Ibaraki-ken 319-11, Japan.

© Japan Atomic Energy Research Institute, 1990

編集兼発行 日本原子力研究所
印刷 山田軽印刷所

Joint Operation of TSTA under the Collaboration.

Between JAERI and DOE-LANL

- An Integrated Loop Operation with 100-g Tritium in July 1988 -

Kenji OKUNO, Mikiyo ENOEDA, Takafumi IDE^{*1}, Hiroshi FUKUI^{*2}
Hiroshi YOSHIDA, Yuji NARUSE, J.L. ANDERSON^{*3}
J.R. BARTLIT^{*3}, R.H. SHERMAN^{*3}, R.V. CARLSON^{*3}
D.O. COFFIN^{*3}, J.E. NASISE^{*3} and R.S. WILLIMS^{*3}

Department of Thermonuclear Fusion Research
Naka Fusion Research Establishment
Japan Atomic Energy Research Institute
Naka-machi, Naka-gun, Ibaraki-ken

(Received January 31, 1990)

Joint operation of the TSTA integrated process loop with 100-g tritium was carried out by JAERI and DOE-LANL in July 1988. One of the major purposes of the present operation was to demonstrate safety of the entire TSTA system for the Technical Safety Appraisal (TSA) conducted by DOE. This joint operation of TSTA was completed successfully and safely.

From a technological point of view, the present operation produced many highlights. In particular, it is noteworthy that preliminary data were obtained as to impurity effects of He on performance of the ISS system by injecting 1 and 3% He with H₂ into the process loop flow.

Keywords: Fusion Fuel Cycle, Tritium Technology, Cryogenic Distillation, Fuel Cleanup, Isotope Separation, Tritium Systems Test Assemb
Assembly

*1 Sumitomo Heavy Industries, Ltd.

*2 Mitsubishi Heavy Industries, Ltd.

*3 Los Alamos National Laboratory

日米協力ANNEX IVに基づくTSTA共同試験
— 100 gのトリチウムを用いた1988年7月のループ試験報告—

日本原子力研究所那珂研究所核融合研究部

奥野 健二・榎枝 幹男・井手 隆裕^{*1}

福井 裕^{*2}・吉田 浩・成瀬 雄二

J. L. ANDERSON^{*3}・J. R. BARTLIT^{*3}

R. H. SHERMAN^{*3}・R. V. CARLSON^{*3}

D. O. COFFIN^{*3}・J. E. NASISE^{*3}

R. S. WILLIAMS^{*3}

(1990年1月31日受理)

本報告書は、日米協力Annex IVに基づいて1988年7月に米国ロスアラモス国立研究所のトリチウムシステム試験施設(TSTA)において、原研第2年次チームが参加して実施したTSTA共同ループ試験の結果をまとめたものである。

本共同ループ試験の主要目的は、DOEによる技術安全審査委員会(TSA)に対してTSTAシステムの安全性を示すことにあった。試験は約8日間にわたって実施され、安全かつ成功裏に終了し、TSTAの安全性がTSAに対して実証された。

また、本試験において多くの技術的成果も得られた。特に、水素同位体分離システムの制御及びその分離特性に及ぼすヘリウムの影響に関しては重要な知見が得られた。

* 1 住友重機械工業㈱

* 2 三菱重工業㈱

* 3 ロスアラモス国立研究所

1. 序 論	1
2. 実 験	3
2.1 ループ試験の概要	3
2.2 TSTAプロセスシステムの概要	5
2.2.1 トリチウム供給・貯蔵系 (UTB)	5
2.2.2 燃料ガス精製系 (FCU)	5
2.2.3 水素同位体分離系 (ISS)	7
2.2.4 ガス移送ポンプ系-1 (TP1)	7
2.2.5 ガス移送ポンプ系-3 (TP3)	8
2.2.6 トリチウム搬入・搬出系 (LIO)	8
2.3 実験手順	8
2.3.1 準 備	9
2.3.2 ループ運転	10
2.3.3 停 止	11
3. 結果及び考察	11
3.1 プロセスシステムの特徴	12
3.1.1 UTB	12
3.1.2 FCU	14
3.1.3 ISS	15
3.2 安全システムの特徴	17
3.2.1 2次格納系 (SEC)	17
3.2.2 トリチウム廃ガス処理系 (TWT)	19
3.2.3 スタック・トリチウムレベル	20
3.2.4 室内トリチウムレベル	20
3.3 不純物ヘリウム影響	21
4. 結 論	23
文 献	25

Contents

1. Introduction	1
2. Experimental	3
2.1 Loop Configuration	3
2.2 Outline of Process Systems	5
2.2.1 UTB	5
2.2.2 FCU	5
2.2.3 ISS	7
2.2.4 TP1	7
2.2.5 TP3	8
2.2.6 LIO	8
2.3 Procedures	8
2.3.1 Preparation	9
2.3.2 Loop operation	10
2.3.3 Shutdown	11
3. Results and Discussion	11
3.1 Characteristics of Process Systems	12
3.1.1 UTB	12
3.1.2 FCU	14
3.1.3 ISS	15
3.2 Characteristics of Safety Systems	17
3.2.1 SEC	17
3.2.2 TWT	19
3.2.3 Tritium radiation level at the TSTA stack	20
3.2.4 Tritium radiation levels in the main cell of TSTA	20
3.3 Impurity Effects of He	21
4. Conclusion	23
References	25

1. INTRODUCTION

In June 1987, the Japan Atomic Energy Research Institute (JAERI) and the United States Department of Energy (DOE) signed a collaborative agreement, Annex IV to the Japan/U.S. Agreement on Fusion Energy, regarding development of technology for fusion-fuel processing. Under the agreement, JAERI and DOE have continued joint operations and experiments on fusion-fuel processing technology with the Tritium Systems Test Assembly (TSTA) at the Los Alamos National Laboratory (LANL).

During the first year of Annex IV (June 11, 1987- June 10, 1988), the technical program summarized in Table 1.1 was carried out at TSTA. The technical program consisted of two complementary parts. The one was development and testing done on individual systems (the Isotope Separation System: ISS, the Fuel Cleanup System: FCU, and the Vacuum System: VAC) [1-4]. The other was the incorporation and operation of the systems to accomplish a complete fuel processing in the integrated flow loop of TSTA [5-8]. Each experiment and operation has produced many technological advances on development of fusion-fuel processing. In particular, the joint operations of the integrated loop of TSTA in June/July 1987 [5-7], February/March 1988 and May/June 1988 [8] were milestones for development of a fusion-fuel processing technology.

In the TSTA operation in June/July 1987, where FCU and

ISS were integrated into the TSTA flow loop, more than 100 g of tritium were processed successfully for the first time. The operation was carried out safely. This fact implies that TSTA in the integrated loop mode could process tritium at the rate of 1 kg per day which would be required as tritium processing capacity for an ITER-sized machine. In the operation, it was also important that an orderly shutdown was accomplished under off-normal condition, without any personnel exposures or release of tritium to environment.

On-line regeneration and decomposition of the captured impurities in the FCU system was first accomplished under full loop operation in February/March 1988. The impurities of 0.9% N_2 and 0.1% CH_4 , added to the process flow, were completely removed with molecular sieve beds cooled at 77 K. On-line regeneration of these beds consisted of the following processes; catalytic oxidation of the impurities to form water, capture of water by freezeout, and decomposition of the captured water by reaction with hot uranium to recycle tritium into the process flow.

During the joint operation in May/June 1988, all process systems of TSTA including VAC were first integrated into the processing flow loop. This implied an establishment of a full tritium-processing loop for fusion reactors.

In Table 1.2 is shown the plan of the major operations of TSTA during the second year of Annex IV. The first operation of TSTA in the second year was performed with the participation

of second JAERI team in late July. One of the major purposes of this operation was to demonstrate the safe operation of the entire TSTA system by using 100-g tritium for the Technical Safety Appraisal (TSA) conducted by DOE. From a technological point of view, this operation had the following important goals;

- to carry out a two-day loop operation where the ISS and FCU process system were integrated,
- to demonstrate that 100 Ci of high purity tritium could be unloaded into a shipping container for TFTR,
- to accumulate the data base on the process systems such as FCU, ISS, UTB, etc.,
- to improved the data on the safety systems such as the secondary containment system (SEC), the tritium waste treatment system (TWT) and the tritium monitoring system (TM), and
- to investigate impurity effects on performance of the ISS system by injecting 1 and 3% He with H₂ into the process flow.

The present report describes mainly the characteristics of the process and safety systems of TSTA observed during the joint operation. The experimental results of impurity effects of He on the performance of the ISS system are also discussed.

2. EXPERIMENTAL

2.1 Loop Configuration

Figure 2.1 shows the conceptual block diagram of the main process flow path in TSTA. Figure 2.2 also shows a diagram of the

of second JAERI team in late July. One of the major purposes of this operation was to demonstrate the safe operation of the entire TSTA system by using 100-g tritium for the Technical Safety Appraisal (TSA) conducted by DOE. From a technological point of view, this operation had the following important goals;

- to carry out a two-day loop operation where the ISS and FCU process system were integrated,
- to demonstrate that 100 Ci of high purity tritium could be unloaded into a shipping container for TFTR,
- to accumulate the data base on the process systems such as FCU, ISS, UTB, etc.,
- to improved the data on the safety systems such as the secondary containment system (SEC), the tritium waste treatment system (TWT) and the tritium monitoring system (TM), and
- to investigate impurity effects on performance of the ISS system by injecting 1 and 3% He with H₂ into the process flow.

The present report describes mainly the characteristics of the process and safety systems of TSTA observed during the joint operation. The experimental results of impurity effects of He on the performance of the ISS system are also discussed.

2. EXPERIMENTAL

2.1 Loop Configuration

Figure 2.1 shows the conceptual block diagram of the main process flow path in TSTA. Figure 2.2 also shows a diagram of the

current main process loop of TSTA. The TSTA consists of the following main process systems; UTB (Uranium tritide storage and supply system), ISS (Isotope separation system), FCU (Fuel cleanup system), NBI (Neutral beam injection simulation system), TP1 and TP3 (gas transfer, mixing and pumping system), IMS (Impurity injection system), LIO (Tritium load-in/load-out system). The process systems integrated in the present operation were UTB, FCU, ISS, TP1, and TP3. The VAC system was not used during this operation. The process flow in the loop operation consisted of two paths; FCU→ISS→TP3→TP1→FCU (solid line in Fig. 2.2) and ISS→TP3→FCU(NBI)→ISS (broken line in Fig. 2.2).

Non-process and safety systems of TSTA were also required during the operation. These were GAN (Gas analysis system), TWT (Tritium waste treatment system), SEC (Secondary containment system), TM (Tritium monitoring system), MDAC (Master data acquisition and control system), and VEN (Building ventilation system). The other safety systems such as ETC (Emergency tritium cleanup system), UPS (Uninterruptible power supply) and the breathing air supply system were available, but were not used during the operation.

Because details of the systems mentioned above have been reported in a previous paper [9], only an outline of the main process systems integrated in the present loop operation will be described in the following section.

2.2 Outline of Process Systems

2.2.1 UTB

The function of the UTB system is to store and recover process gas composed of hydrogen isotopes which are used in the TSTA process loop. The UTB mainly consists of five uranium beds (UTB-1, 2, 3, 4, and 5), a turbo-molecular vacuum pump, and a surge tank (265 l), as shown in Fig. 2.3. Each bed contains 6 kg (25.2 mole) of depleted uranium, where the process gas is stored and recovered as uranium tritide. To offload the process gas into the TSTA process loop, the beds are heated and the gas is directed to the ISS columns. Each bed is enclosed in a vacuum jacket to provide thermal isolation and to prevent the permeated tritium from being released to the glovebox. The vacuum jacket are evacuated with the turbo-molecular pump and the exhaust gas is sent to the TWT systems. The surge tank is used as a standard volume for tritium inventory measurement prior to offloading into the process loop of TSTA.

2.2.2 FCU

The function of FCU in the process loop of TSTA is to remove impurities, such as N_2 , O_2 , CO_4 and NO_3 (Q=H, D and T), from the processing fuel stream. The FCU is designed to reduce the total concentration of these impurities in the stream to less than 1 ppm. The stream processed in FCU is fed to the main feed stream to the ISS system. As shown in Fig. 2.4, the streams in FCU consist of a main flow to ISS, a regeneration flow and a NBI flow

for simulating NBI. During the loop operation, only the ISS and NBI flows were used. The main components and their functions in each flow are as follows:

A. Main (ISS) flow

a) Catalytic reactor (CR1)

- Conversion of free oxygen in the flow into water by combining with hydrogen isotopes.

b) Molecular sieve bed freezers (MSBF1 and 2)

- Collection of the water, which is formed in CR1, on fins cooled with liquid nitrogen.

c) Cryogenic molecular sieve beds (MSB1 and 2)

- Collection of all remaining impurities except helium in the flow after passing through MSBF1 and 2.

B. Effluent (TWT) flow

a) Catalytic reactor (CR2)

- Conversion of hydrogen isotopes, which constitute compounds such as CO_4 , NO_3 , etc., into water.

b) Uranium beds (HMB4 and 5)

- Liberation of hydrogen isotopes from the water released by raising the DTOF temperature, leaving the hydrogen isotopes to be returned to the main feed of FCU.

C. NBI flow

a) Cryogenic molecular sieve beds (MSB3 and 4)

- Collection of all remaining impurities in the NBI flow.

2.2.3 ISS

In the ISS system, hydrogen isotope separation is performed by a cryogenic distillation method. Figure 2.5 illustrates diagrams of flow and control of ISS. The main components of the ISS are four distillation columns (I, H, D, and T) linked to each other and two hydrogen isotope equilibrators (EQ). As can be seen in Fig. 2.5, the process gas, which has had non-hydrogen species removed in FCU, is fed to the column I and separated isotopically into the following four streams by the column H, D and T;

- A) an essentially tritium-free stream of H_2 and HD species for disposal of H waste (top flow from the column H),
- B) a high-purity D_2 stream for simulated neutral beam injection and refueling (top flow from the column D),
- C) a stream of basically pure DT for refueling to a torus (top flow from the column T and bottom flow from the column D), and
- D) a high-purity T_2 stream for refueling and studies on tritium properties and tritium effects on materials (bottom flow from the column T).

In the present operation, these streams except A are combined at TP3 to recycle to the FCU system. Stream A returns to the feed of the column H or exhausts to the TWT system as a waste gas.

2.2.4 TP1

The TP1 consists of a scroll pump (S) and two metal bellows pumps (MBPA and MBPB), as shown in Fig. 2.2. This system was used for the regeneration of the VAC system, and the evacuation of the

LIO system. The function of TP1 in this operation was to evacuate the TFTR shipping container at the LIO system for a demonstration of tritium shipping to TFTR.

2.2.5 TP3

The TP3 consists of four metal bellows pumps (MBPA1, MBPA2, MBPB1, and MBPB2), a gas mixture (MX) and a hydrogen isotope equilibrators (EQ), as shown in Fig. 2.2. This system provides the main process flow in the present operation.

2.2.6 LIO

The LIO system comprises an input/output manifold for attachment of three tritium shipping containers and two sampling bottles. In the operation, one of the shipping containers was used to transfer 100 Ci of tritium to a PC for future possible shipment to TFTR.

2.3 Procedures

Major procedures for the process and safety systems during the present operation are listed in Tables 2.1(a), (b), (c), and (d). The whole operation period was divided into three stages; preparation, loop operation and shutdown. The followings are brief descriptions of procedures in each stage.

2.3.1 Preparation

(1) FCU

Major procedures in the preparation stage for the FCU system were;

- heating and evacuation of CR1, MSB1 and MSB4 for the regeneration (Table 2.1(a)),
- evacuation of the vacuum jackets of CR1, MSB1 and MSB4 (Table 2.1(a)),
- cooling down of CR1, because no impurity except He would be added to the main process loop during the present operation,
- supply of liquid nitrogen (LN_2) to MSB1 and MSB4 (Table 2.1),
- leak-checking of the FCU system using low level tritium (Table 2.1 (b)), and
- evacuation of the FCU system (table 2.1 (b)).

(2) ISS

In the preparation stage for the ISS system, the following procedures were required;

- evacuation of the ISS vacuum jacket (Table 2.1(a)),
- helium gas supply for purging the ISS columns (Table 2.1(a)),
- cooling down of the ISS thermal shield with liquid nitrogen (Table 2.1(b)),
- cooling down of the columns with the cryogenic He refrigerator (Table 2.1(b)), and
- evacuation of the columns filled with He gas (Table 2.1(b)).

(3) UTB

The following preparation procedures were mainly required

for the UTB system;

- evacuation of the UTB vacuum jackets,
- pre-heating of UTB-1, UTB-3 and UTB-4 to 473 K (Table 2.1(b)),
and
- heating of UTB-1 and UTB-3 to 673 K (Table 2.1(b)).

The loading of hydrogen isotopes into the process loop was initiated after the above procedures were completed. At first, hydrogen isotope gas was loaded to the column I and T from UTB-1 and UTB-3, respectively. Next, hydrogen isotope gas was loaded to the column H and D from UTB-2 and UTB-4, respectively. The hydrogen isotopes loading to FCU was performed through the ISS columns.

2.3.2 Loop operation

The full loop operation was started through the main flow path; FCU→ISS→TP3→TP1→FCU and the NBI path; ISS→TP3→FCU(NBI)→ISS after the completion of the tritium loading from UTB. The main flow path is indicated in Fig. 2.2 using a solid line. The NBI flow path is shown by a broken line in the figure.

Major procedures performed during the loop operation were;

- injection of impurities of 1 and 3% He and 1% H₂ (in TP of Table 2.1(c)),
- removal of H₂, HD and He from the top of the column H to TWT (Table 2.1(c)),
- measurements of He and H-D-T separation characteristics in ISS

by gas chromatography, and

- loading of 100 Ci of pure tritium from the bottom of the column T into the shipping container (12 l) (Table 2.1(d)).

2.3.3 Shutdown

The ordinary shutdown procedures of the process loop were;

- termination of the process gas circulation through flow paths FCU→ISS→TP3→TP1→FCU and ISS→TP3→FCU(NBI)→ISS (Table 2.1(d)),
- opening paths from the ISS columns to the UTB,
- warming of ISS by stopping He refrigerant and liquid nitrogen supply, and continuation of offloading of H-D-T mixture to UTB (in ISS and UTB of Table 2.1(d)),
- warming of cryogenic molecular sieve beds in FCU and NBI return process by stopping liquid nitrogen supply (in FCU of Table 2.1(d)),
- evacuation of residual gases (including impurities) in the integrated loop using TP1, or to TWT through UTB with the house vacuum system (in TP of Table 2.1(d)), and
- all electrical heaters off in the process components of ISS.

3. RESULTS AND DISCUSSION

As can be seen from Table 2.1(a)-(d), the present joint operation of TSTA was carried out from July 21 to 26, 1988.

This period was subdivided into the preparation, loop operation and shutdown stage. During the loop operation, He injection into the process gas was carried out to study impurity effects of He

by gas chromatography, and

- loading of 100 Ci of pure tritium from the bottom of the column T into the shipping container (12 l) (Table 2.1(d)).

2.3.3 Shutdown

The ordinary shutdown procedures of the process loop were;

- termination of the process gas circulation through flow paths FCU→ISS→TP3→TP1→FCU and ISS→TP3→FCU(NBI)→ISS (Table 2.1(d)),
- opening paths from the ISS columns to the UTB,
- warming of ISS by stopping He refrigerant and liquid nitrogen supply, and continuation of offloading of H-D-T mixture to UTB (in ISS and UTB of Table 2.1(d)),
- warming of cryogenic molecular sieve beds in FCU and NBI return process by stopping liquid nitrogen supply (in FCU of Table 2.1(d)),
- evacuation of residual gases (including impurities) in the integrated loop using TP1, or to TWT through UTB with the house vacuum system (in TP of Table 2.1(d)), and
- all electrical heaters off in the process components of ISS.

3. RESULTS AND DISCUSSION

As can be seen from Table 2.1(a)-(d), the present joint operation of TSTA was carried out from July 21 to 26, 1988. This period was subdivided into the preparation, loop operation and shutdown stage. During the loop operation, He injection into the process gas was carried out to study impurity effects of He

on ISS performance. The followings are detailed descriptions of characteristics of each process and safety systems observed in the preparation, loop operation and shutdown stage. The experimental results obtained for impurity effects of He on the ISS performance are also discussed.

3.1 Characteristics of Process Systems

3.1.1 UTB

Figure 3.1 shows the temperature profiles of the UTB's. It can be seen from the figure that there were two temperature rises at the UTB beds during the present operation. The first one in the preparation stage resulted from heating procedure for process gas loading to the ISS columns. The other one in the shutdown stage was ascribed to an exothermic reaction between hydrogen isotopes and uranium during process gas loading to the UTB's.

The following is details of the characteristics of the UTB's during the process gas offloading in the preparation stage and loading procedure in the shutdown stage.

(1) Offloading

Figure 3.2 shows detailed temperature profiles of UTB-1, 2, 3, 4, and 5 during offloading the process gas to the ISS columns. The UTB-1, 3 and 4 were preheated at 473 K for the offloading. The preheated UTB-1 and 3 were then heated to 673 K. When the pressures of the process gas desorbed from uranium reached 800 torr in the beds, the gas was offloaded to the column I and T.

In Fig. 3.3 is shown the variation of the pressure in the column I. A pressure rise to about 600 torr occurred following the offloading of UTB-1 and 3. After completing the offloading of UTB-1 and 3 by heating to about 723 K, UTB-2 and 4 were heated to 673 K. The desorbed process gas was offloaded to the column H and D in a similar manner as the case of the UTB-1 and 3. During the offloading, UTB-5 was left at ambient temperature for an emergency recovery of the offloaded process gas. In a series of the offloading procedures, about 85.5 moles of H-D-T mixture were supplied as the process gas into the process loop from the four UTB's. The fractions of H, D and T in the mixture were estimated to be 24, 230 and 107 g, respectively.

(2) Loading

The process gas from the loop was loaded back into the UTB's at ambient temperature after the completion of loop operation. The uranium beds used in the loading procedure were UTB-1, 2, 3, and 5. Figure 3.4 shows temperature profiles of the four UTB's used for the loading of the process gas. Figure 3.5 shows pressure profiles in the four ISS columns during the loading procedure. It can be seen from both figures that temperature rises in the UTB's due to the exothermic reaction mentioned above occurred in correlation with decreasing pressures in the four columns. However, the decreasing rates of the column pressures, that is, the loading rates of the UTB's except UTB-5 were slower than those in the previous operations [5-8]. This could be ascribed to a blanketing effect of He, which was added into the

process gas as an impurity, on the reaction between uranium and hydrogen isotopes. Actually, the blanketing effect appeared most severe in UTB-2, because it was connected directly with the column H where the concentration of He was expected to be the highest among the four columns. To remove the blanket effect in UTB-2, pressure swings by using pressure difference between UTB-2 and the column H were performed several times (in UTB of Table 2.1(d)). A temporary pressure increase in column H (Fig. 3.5) was due to the pressure swing. The pressure swing procedures, however, did not lead to complete removal of the blanketing effect. Finally, for complete removal of the blanketing effect, a flow path from the UTB's to the TP3 was opened and a flow path, ISS→UTB→TP3→ISS, was established (Fig. 3.4 and 3.5, and TP of Table 2.1(d)). This loop flow operation removed the blanketing effect and resulted in the complete loading of the process gas back to the UTB's.

3.1.2 FCU

Figures 3.6(a) and (b) show temperature profiles of CR1 and MSB1 in the main flow (Fig. 2.5) and MSB4 in the NBI flow of FCU (Fig. 2.5). Prior to the loop operation, CR1, MSB1 and MSB4 were regenerated by heating to around 400 K for about 20 hours. After the regeneration, MSB1 and MSB4 were cooled to 77 K. However, CR1 was left at ambient temperature because no impurities except He were added into the main process flow in the present loop operation. Figures 3.7(a) and (b) show pressure profiles of CR1

and MSB4. The pressure variation in CR1 and MSB4 were found to be very similar to each other, while they were placed in the different flows, that is, in the main flow and the NBI flow of FCU. Pressure rises before the loop operation were due to leak checking procedures.

3.1.3 ISS

Figures 3.8 and 3.9 show pressure and temperature variation of the four ISS columns during the preparation stage (Table 2.1(a) and (b)). The columns were purged several times with He and backfilled with 600 torr of He until process gas loading from the UTB's. Cooling down of the columns backfilled with He gas was initiated by supplying liquid nitrogen to the thermal shield of the columns. After turning on the helium refrigerator and evacuating the He gas, both column I and H were cooled down to approximately 20 K; although, their temperatures increased temporarily due to circulation of He refrigerant which was not cooled well. When the column temperatures reached 50 K, the process gas was loaded into the column I and T from UTB-1 and 3. However, cooling of the column D and H was found to be delayed, because their cooling manner was different from that of column I and T [9]. After column D and H cooled down well, the process gas was loaded into them from UTB-2 and 4.

The loop operation of the TSTA system through the main flow (FCU→ISS→TP3→FCU) and the NBI flow (ISS→TP3→FCU(NBI)→ISS)

was initiated at 13:40 on July 23. The loop operation was continued for about 2 days. During the loop operation, the ISS system was controlled so that liquid levels of the column I and H were kept constant with flow rates from the bottom streams. Liquid levels in the reboilers of column D and T were also kept constant with outputs of their reboiler heaters. Table 3.1 summarizes average values of operational parameters of each column during the loop operation. In this table, P represents the column pressure; Q the liquid level in the reboiler; W the output of the reboiler heater; F the flow rate at the top, bottom and feed stream; T the temperature of the condenser and reboiler; V the vapor velocity; R the reflux ratio; and H the liquid holdup.

Pressure and temperature variation of the ISS columns observed under the operational conditions listed in the table are shown in Figs. 3.10 and 11. From Figs. 3.10(a) and (b), the operational pressure in each column was found to be maintained at around 800 Torr, while a significant pressure variation occurred in each column due to impurity injections of He with H₂. The pressure variation of the four ISS columns were also found to be consistent with those of CR1 and MSB4 in FCU (Figs. 3.7(a) and (b)) throughout the loop operation. It can be seen from Figs. 3.12(a)-(d) that the temperatures at the bottom and top, that is, at the reboiler and condenser of each column were controlled between 20 and 27 K. The temperature at the condenser in each column was naturally lower than that

at the reboiler, because lighter hydrogen isotopes with lower boiling points were concentrated at the condenser. Large variations of the bottom temperature in each column resulted from losses of liquid-holdups of hydrogen isotopes in the reboiler and their recovery procedures.

In the final stage of loop operation, 100 Ci of pure T_2 was transferred to the TFTR container at LIO from the bottom of the column T for future possible shipment to TFTR. The isotopic purity of the tritium gas was analyzed to be better than 99.99% with a mass spectrometer.

3.2 Characteristics of Safety Systems

3.2.1 SEC

The process systems and process lines of TSTA are contained in the SEC system which consists of gloveboxes and glovebox atmosphere controllers. The atmospheric gas, N_2 , in the gloveboxes is automatically purged to the TWT system, when their tritium radiation levels exceeded 1 mCi/m^3 . The tritium radiation levels in the gloveboxes were monitored during the present operation as follows.

(1) Tritium radiation levels of ISS gloveboxes

Figure 3.13 shows the radiation level of the two ISS gloveboxes and the UTB glovebox during the operation.

The radiation level in the ISS-GB1 (from the ISS plumbing) began to increase with increasing ISS column pressure during tritium loading from the two uranium beds (UTB-1 and UTB-3).

The radiation level also increased when the loop flow operation was initiated. These increases of the radiation level resulted from tritium leakage through a rupture disc at the top of column I. Therefore, the radiation level in the ISS-GB1 depended on the pressure and tritium concentration in the top of the column I.

Most peaks of the radiation level in the ISS-GB2, where the ISS-GAN system is contained, were caused by unidentified small tritium leaks in the plumbing to the gas chromatographs.

Significant increase of the radiation level in the ISS-GB3, where the UTB's are installed, were not observed except a small peak.

(2) Tritium radiation level of the FCU glovebox

Figure 3.14 shows the radiation level in the FCU glovebox during the loop operation. No leaks were observed on the pre-leak check using low level tritium. The radiation level, however, increased gradually after the start of the loop operation. This might be ascribed to small tritium leaks in the plumbing of the FCU.

(3) Tritium radiation levels of LIO and INV gloveboxes

As shown in Fig. 3.15, a plateau at around 0.9 mCi/m^3 was observed on the radiation level in LIO-GB. This tritium release occurred when the tritium shipping container (LP-12) was disconnected from the LIO manifold after loading pure tritium from the bottom of the column T. The source of tritium is from the contaminated short connecting tube on the container.

Successive contamination was not observed during loading and offloading operation of tritium gas.

(4) Tritium radiation level of the TPU glovebox

Figure 3.16 shows the radiation level in the TP1 and TP3 gloveboxes. A notable increase was observed in the radiation level in the TP1 glovebox. This corresponded to the loading procedure of the pure tritium from column T to the tritium container (LP-12). Unidentified leaks from the plumbing may contribute to this increase of the radiation level.

3.2.2 TWT

In the TWT system shown in Fig. 3.17, tritium-bearing gases exhausted from various systems in TSTA are treated to reduce their tritium concentration to a level that will permit release from the TSTA stack to the environment.

Figure 3.18 shows the radiation level on the low pressure receiver (LPR) during the present operation, which is located at the inlet of TWT. The first small peaks were ascribed to the evacuation of the main process loop. The most peaks observed during the loop operation were due to exhaust gases from the ISS-GAN system and the top of the column H during the He impurity injection experiments. It is possible to estimate the total amount of tritium exhausted to TWT. For the exhausted tritium from ISS-GAN, the amount was estimated to be 1204 Ci based on the composition, pressure, number of sampling and volume of the sampling manifold. The amount of the tritium

exhausted from the top of column H was also estimated to be 39.6 Ci based on the tritium level and the flow rate to LPR of TWT. Therefore, at least about 1240 Ci of tritium was wasted to the TWT system during the loop operation.

Figure 3.19 shows the tritium radiation level at the exit of TWT. The first peak in the figure resulted from the evacuation of the columns of the ISS system. Saturation of the molecular sieves bed (MSB) in TWT caused the second one. It can be seen by comparison of Figs. 3.19 and 3.18 that the tritium radiation level at the exit of the TWT was above three orders of magnitude lower than at the inlet. This means that the tritium concentration of the gases wasted to TWT were reduced by more than three orders of magnitude by the TWT system.

3.2.3 Tritium radiation level at the TSTA stack

The exhaust gases detritiated in the TWT were released from the TSTA stack to environment after monitoring their tritium concentration. The tritium concentration monitored at the stack during the operation is shown in Fig. 3.20. Sharp peaks in the figure were due to calibration of the monitor with ^{137}Cs . It can be seen from the figure that no abnormal tritium level were detected during the whole operation. This fact means that the present joint operation was carried out without any abnormal tritium release to the environment.

3.2.4 Tritium radiation levels in the main cell of TSTA

Room monitors are strategically placed at location where

tritium leaks may occur, as shown in Fig. 3.21. Each monitor continuously samples the air in the main cell through hoses or tubes connected in parallel. Figures 3.22(a)-(c) show the radiation levels of the room monitors during the operation. Sharp peaks in the figures were due to the calibration of the tritium monitors. It can be seen from the figures that no significant increases of the radiation level were detected during the whole operation. This fact means that the present operation was carried out without any tritium release to the main cell of TSTA.

3.3 Impurity Effects of He

To study impurity effects of He on the performance of the ISS system, helium was injected into the process gas at concentration of 1 and 3% with 1% H₂ during the loop operation. It was expected that the injected He would concentrate at the top of the column H. Therefore, impurity effects of He would be shown most clearly on gas compositions of the top stream in the column H. On these expectation, we measured the compositions of the feed and top stream in the column H by radio-gas chromatography. The results of the feed and top stream are shown in Fig. 3.23 and 3.24 together with the experimental procedures, respectively. As shown in the figures, the He injection was tried three times during the loop operation. The second and third one were, however, forced to terminate midway, because too much tritium was exhausted from

the top stream of column H into TWT. Hence, our attention was focused on only the experiment results obtained in the first He injection.

For the first He injection experiment, a composition of the top stream was calculated by assuming a steady state condition. The calculation was carried out based on the observed composition of the feed stream (Fig. 3.23) and an assumption that HETP in the column H was 5 cm. The results was superimposed in Fig. 3.24.

From Fig. 3.23 and 3.24, the mole fraction of He in the top stream (more than 0.1) during the first He injection was found to be about one order of magnitude greater than that in feed stream (about 0.01). This implies that the injected He was clearly concentrated at the top the column H, as noted above. The concentrated He was exhausted into the TWT system with the other products in the top of the column H. A mole fraction of He at a steady state would be expected to be about 0.31 by the calculation, as shown in Fig. 3.24. On the other hand, the mole fractions of the hydrogen isotopes at the top steam also changed with the He injection. The mole fractions of HT and D₂ increased with increasing He fraction. On the contrary, a tendency to decrease was observed for the mole fractions of H₂ and HD. It is interesting that each mole fraction changed as though it would approach the calculated value at the steady state, that is, 0.03 for HT, 0.22 for HD, 0.44 for D₂, and 2.4×10^{-6} for DT. Because of lack of observed

data for the mole fractions of the hydrogen isotopes in the steady state, it is difficult to discuss quantitative agreement between the calculated and observed values. It can be concluded that the present He injection experiment provided preliminary knowledge concerning impurity effects of He on the performance of the column H. To discuss further the impurity effects of He on the performance of the whole the ISS system, much more data should be acquired in a transient and steady state during He injection.

4. Conclusion

The joint operation of the TSTA system was carried out by JAERI and DOE-LANL from July 21 through 26, 1988. One of the purposes of the present operation was to demonstrate the safe operation of the whole TSTA system to the TSA team. During this period of the joint operation, there were no technical troubles. Moreover, no abnormal tritium release occurred into the main cell of TSTA or to the environment. These facts show the TSA team the safe operation of the entire TSTA system.

From a technical point of view, the present operation produced the following highlights:

- (1) The integrated process loop except the VAC system was operated with about 85.5 mole of a mixture of hydrogen isotopes (T; 107 g, D/T ratio; 3.15) for two days.
- (2) The ISS system was operated with the FCU and NBI return

data for the mole fractions of the hydrogen isotopes in the steady state, it is difficult to discuss quantitative agreement between the calculated and observed values. It can be concluded that the present He injection experiment provided preliminary knowledge concerning impurity effects of He on the performance of the column H. To discuss further the impurity effects of He on the performance of the whole the ISS system, much more data should be acquired in a transient and steady state during He injection.

4. Conclusion

The joint operation of the TSTA system was carried out by JAERI and DOE-LANL from July 21 through 26, 1988. One of the purposes of the present operation was to demonstrate the safe operation of the whole TSTA system to the TSA team. During this period of the joint operation, there were no technical troubles. Moreover, no abnormal tritium release occurred into the main cell of TSTA or to the environment. These facts show the TSA team the safe operation of the entire TSTA system.

From a technical point of view, the present operation produced the following highlights:

- (1) The integrated process loop except the VAC system was operated with about 85.5 mole of a mixture of hydrogen isotopes (T; 107 g, D/T ratio; 3.15) for two days.
- (2) The ISS system was operated with the FCU and NBI return

processes under cryogenic distillation conditions for two days.

- (3) The new data regarding characteristics of the process and safety systems during the operation were accumulated.
- (4) It was demonstrated that approximately 100 Ci of high purity tritium (more than 99.99%) could be loaded into a PC from the bottom of the column T.
- (5) Preliminary data were obtained as to impurity effects of He on performance of the ISS system when He was injected into the process flow at the concentration of 1 and 3%.

REFERENCES

- 1) T. Yamanishi, H. Yoshida, T. Naito, S. Hirata, R.H. Sherman, J.R. Bartlit, and J.L. Anderson, "Hydrogen Isotope Separation Study with TSTA Cryogenic Distillation System, - Single Column Experiment with D-T System -", JAERI-M 88-253 (1988).
- 2) T. Yamanishi, H. Yoshida, H. Fukui, T. Naito, S. Hirata, R.H. Sherman, K.M. Gruetzmacher, J.R. Bartlit, and J.L. Anderson, "Hydrogen Isotope Separation Study with The TSTA Cryogenic Distillation System, - Two-column Experiment with H-D-T -", JAERI-M 88-254 (1988).
- 3) T. Yamanishi, H. Yoshida, S. Hirata, T. Naito, Y. Naruse, R.H. Sherman, J.R. Bartlit, K.M. Gruetzmacher, and J.L. Anderson, "Single Column and Two-Column H-D-T Distillation Experiments at TSTA", Fusion Technology, 14 (1988) 489-494.
- 4) R.H. Sherman, J.R. Bartlit, K.M. Gruetzmacher, H. Yoshida, T. Yamanishi, T. Naito, S. Hirata, and Y. Naruse, "Operation of the TSTA Isotope Separation System with 100 Gram Tritium", Fusion Technology, 14 (1988) 1273-1276.
- 5) H. Yoshida, S. Hirata, T. Naito, T. Yamanishi, J.L. Anderson, J.R. Bartlit, R.V. Carlson, D.O. Coffin, R.H. Sherman, and R.S. Willims, "TSTA Loop Operation with 100 Gram-level of Tritium, - Milestone Run in June 1987 -", JAERI-M 88-204 (1988).
- 6) H. Yoshida, S. Hirata, T. Naito, T. Yamanishi, J.L. Anderson, J.R. Bartlit, R.V. Carlson, D.O. Coffin, R.H. Sherman, and R.S. Willims, "TSTA Loop Operation with 100 Gram-level of

Tritium, - Milestone Run in July 1987 -", JAERI-M 88-205 (1988).

- 7) J.L. Anderson, J.R. Bartlit, D.O. Coffin, F.A. Damiano, R.H. Sherman, R.S. Willims, H. Yoshida, T. Yamanishi, T. Naito, S. Hirata, and Y. Naruse, "Experience of TSTA Milestone Run with 100 Fram-level of Tritium", Fusion Technology, 14 (1988) 438-443.
- 8) H. Yoshida, H. Fukui, S. Hirata, T. Yamanishi, T. Naito, J.L. Anderson, J.R. Bartlit, D.O. Coffin, R.V. Carlson, R.S. Willims, C. Walthers, and J.E. Nasise, "TSTA Loop Operation with 100 Gram-level of Tritium, - Full Components Milestone Run in June 1988 -", JAERI-M 88-242 (1988).
- 9) TSTA design teams, "Tritium Systems Test Assembly; Final Safety Analysis Report", SAR-82-1F, Los Alamos National Laboratory (1982).

Table 1.1 Major Experiments & Operations at TSTA, First Year of Annex IV

<u>Date</u>	<u>Operation</u>	<u>Description</u>
1. June 22-26, 1987	loop test of FCU/ISS	with continuous impurity flow
2. July 23-27, 1987	loop test of FCU/ISS	with continuous impurity flow
3. September 1987	maintenance on ISS	lower ISS vacuum jacket after tritium use
4. October 4-9, 1987	non-loop ISS (UTB, TPU)	single column experiments of ISS
5. October 1987	FCU-related testing	begin assembly/tests (w/o tritium) of high temperature metal beds
6. December 6-11, 1987	non-loop ISS (UTB, TPU)	single column experiments of ISS
7. January 1988	non-loop FCU	non-tritium test of FCU operation
8. February 7-9, 1988	loop test of FCU/ISS	preparatory for first full integration of FCU/ISS with continuous impurity flow
9. February 21-24, 1988	loop test of FCU/ISS	--same as item 8 above--
10. February 28-- March 4, 1988	loop test of FCU/ISS	first full integration of FCU/ISS with continuous impurity flow
11. March- May 1988	non-loop VAC tests	without tritium
12. April 4-8, 1988	non-loop ISS (UTB, TPU)	ISS experiments, 2 column
13. May 31-June 6, 1988	loop test of VAC/FCU/ISS	first integrated operation of full fuel processing loop

Table 1.2 Schedule of Main Experiments at TSTA, Second Year of Annex IV

<u>Date</u>	<u>Operation</u>	<u>Description</u>
1. July 19-26, 1988	loop test of FCU/ISS	for Technical Safety Appraisal
2. Beginning of December, 1988	non-loop ISS	two column experiments of ISS helium injection to ISS
3. February-March, 1988	loop test of FCU/ISS(VAC)	long term operation
4. January, 1989	non-loop test	alternative getter materials experiments
5. April, 1989	non-loop	Raman spectroscopy experiments

Table 2.1(b) Operation Schedule during the Run

		Preparation Stage					
Date	7/22						
Time	6	12	18	6	12	18	
F C U				8:13 \square LN ₂ Supply to MSB1,4 14:01 CR1 18:20 14:18 MSB1 18:20 14:28 MSB4 19:38			
I S S	7:08 \square LN ₂ Supply			9:08 Evacuation 10:29 Loading to ISS 7:57 He Refrigerator ON \square 10:36 Col-I 15:10 18:19 Col-H 23:27 10:36 Col-T 13:41 Col-D 20:19			
U T B			16:36 UTB-1 Heating (to 200 °C) 16:36 UTB-3 Heating (to 200 °C) 16:36 UTB-4 Heating (to 200 °C)	7:47 15:16 (to 400 °C) UTB-2 Heating 23:24 7:51 13:47 (to 400 °C) 20:25 (to 400 °C)			
T P							
L I O							
T W T	7:12	10:05	10:31	16:17		9:47 Recycling 10:26	

Table 2.1(c) Operation Schedule during the Run

Preparation Stage		Loop Operation					
Date	7/23						7/24
Time	6	12	18	6	12	18	
F C U	7:53 ↗ Loading to CR1 8:01 ↗ Loading to MSB1 8:43 ↗ Loading to MSB4						
I S S	10:08 ↗ Change Col-I Feed Point from Top to Middle 14:02 ————— 1:56 2:16 3:28 Remove of He, H ₂ , HD (Top of Col-H to TWI) 14:34 ————— 15:12 16:02 15:12 16:38						
U T B							
T P	13:40 ↗ Loop Operation Start 14:28 ————— 16:09 20:33 22:53 Impurity Injection (1% ³ H ₂ , 1% ⁴ He) (1% ³ H ₂ , 3% ⁴ He) 23:03 16:01 16:38 Impurity Injection (1% ³ H ₂ , 3% ⁴ He)						
L I O	17:17 — 17:28 Attachment of LP12 Detachment of PC572						
T W T	8:27 8:53 8:56 9:03 Recycling	14:59 15:25 Recycling		9:46 10:12 Recycling			

Table 2.1 (d) Operation Schedule during the Run

Loop Operation		Shutdown Stage			
Date	7/26				
Time	6	12	18	18	
F C U		15:07 ↻ LN ₂ Supply Stop			
I S S		15:35 ↻ He Refrigerator off			
		15:37 ↻ LN ₂ Supply Stop			
U T B		15:02	11:15		
		15:03	11:15		
		UTB-1 UTB-2 (15:12-15:20 Pressure Swing for Blanketing Effect)			
		15:02	11:16		
		15:04			
		UTB-5			
T P	Loop Operation ↻	14:58			
		18:21, 18:35	8:52, 10:28, 11:31	15:00	
		Loop Operation for Blanketing Effect (ISS-UTB-TP3-ISS)	Loop Evacuation of Loop for Loading to UTB		
L I O	12:16, 13:26, 14:42		10:47	11:00	
	3 Flushes of LP12	14:44	Loading to Sampling Bottle		
	Sampling of Pure T ₂ to LP12				
T W T			8:30	17:21	
			MSC Heating (Regeneration)		

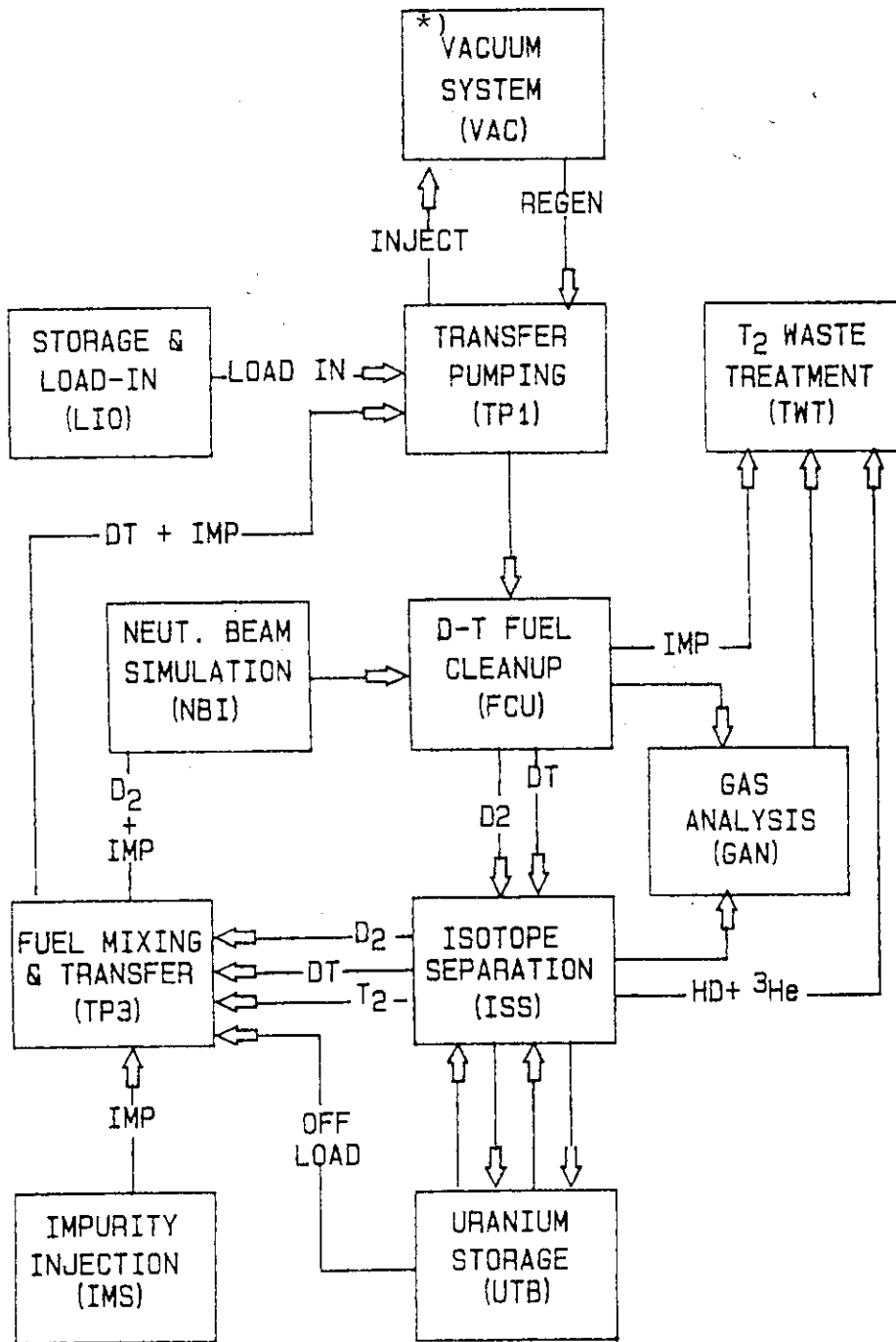

*)VAC was not used during the run.

Fig. 2.1 Conceptual block diagram of TSTA.

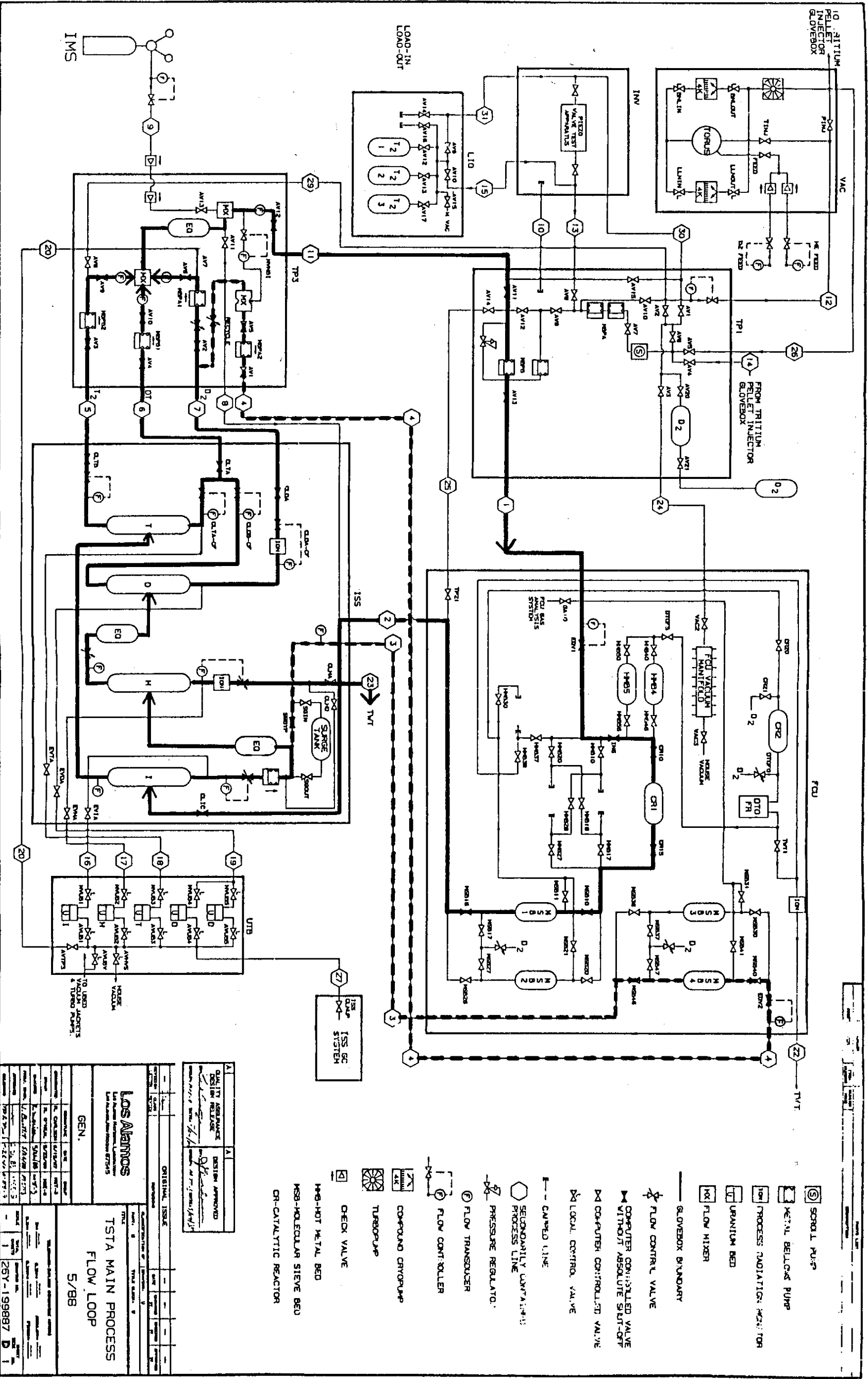

Fig. 2.2 Current main process loop of TSTA.

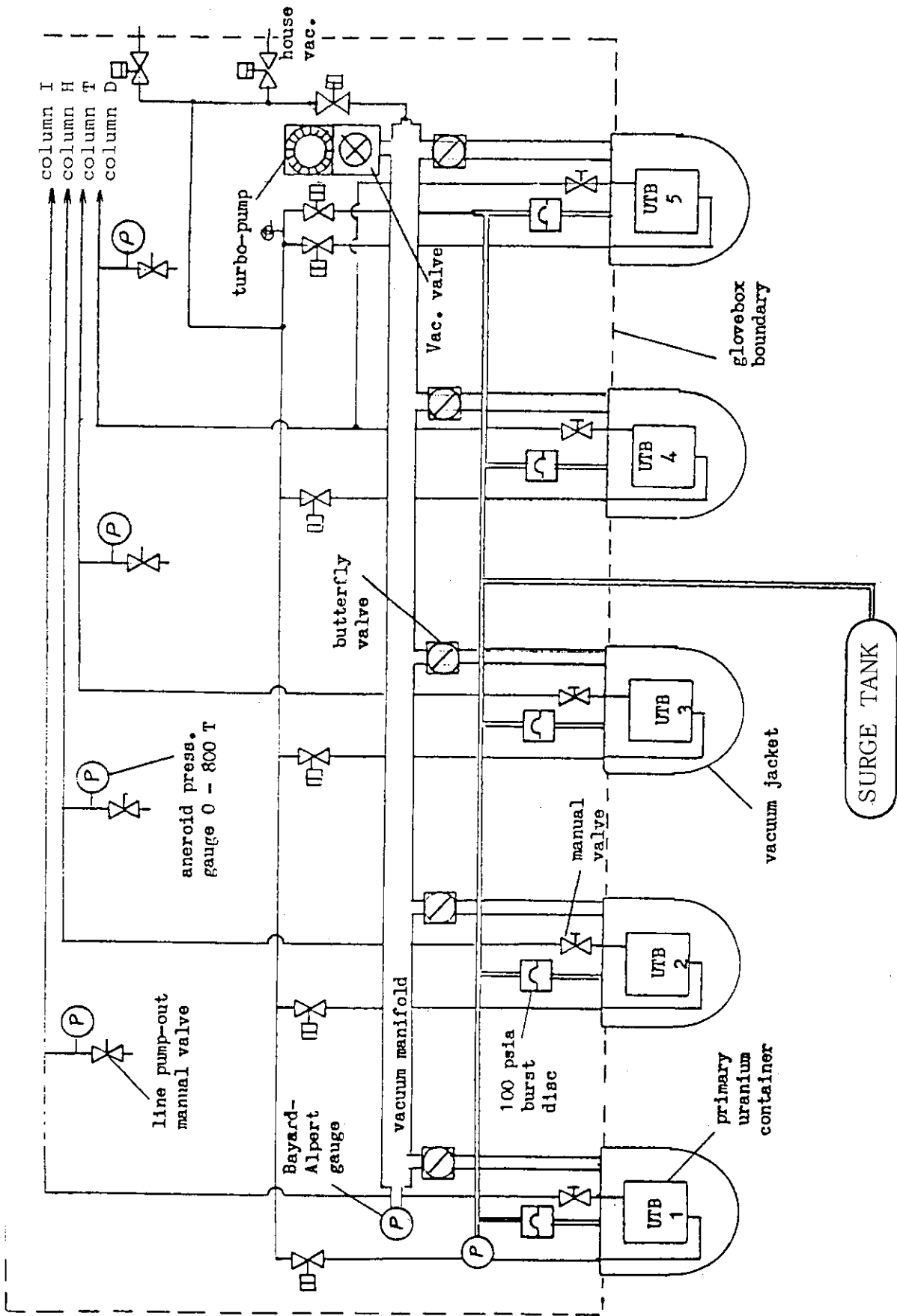

Fig. 2.3 Schematic configuration of the UTB system.

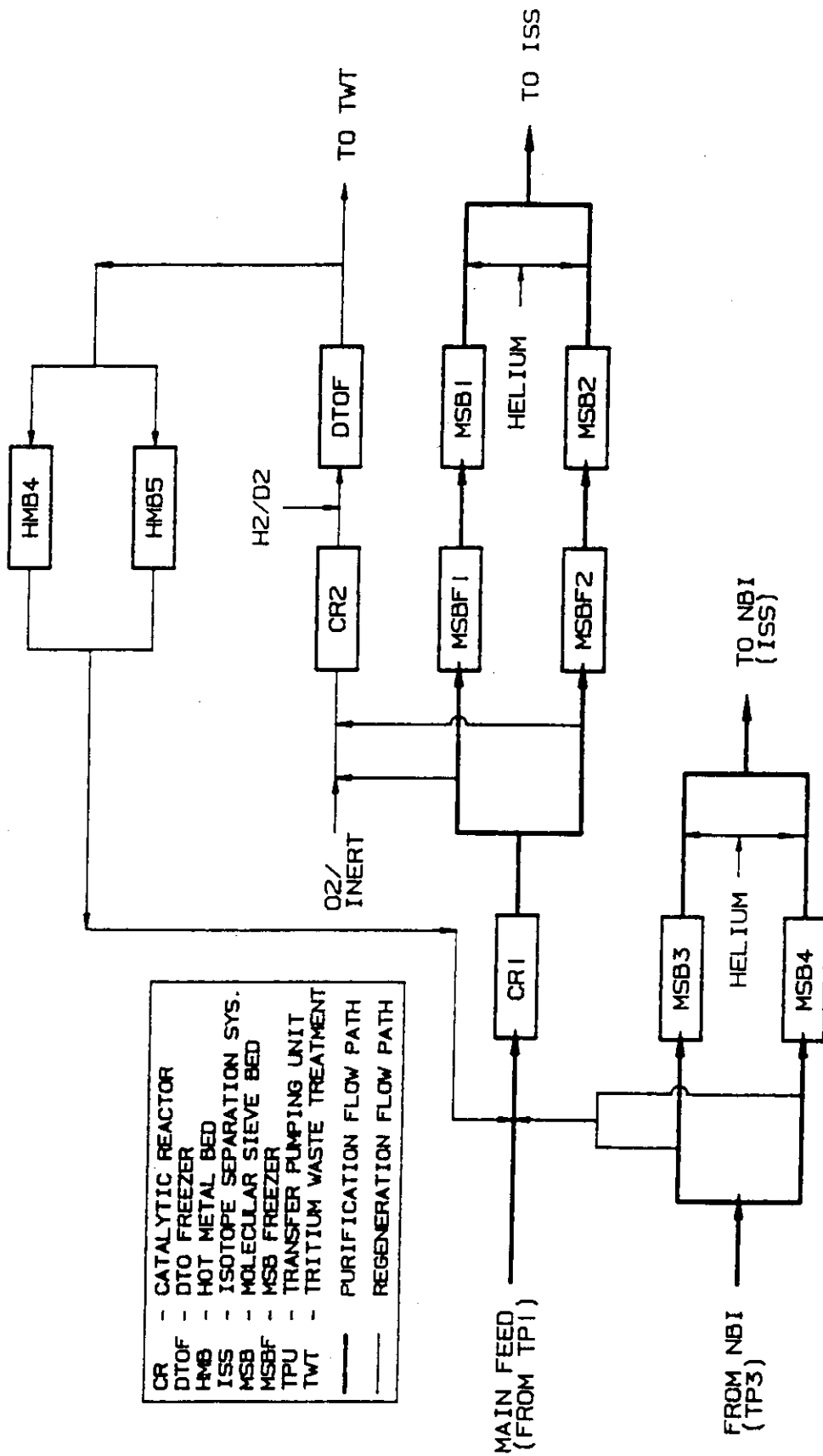

Fig. 2.4 Flow paths in the FCU system.

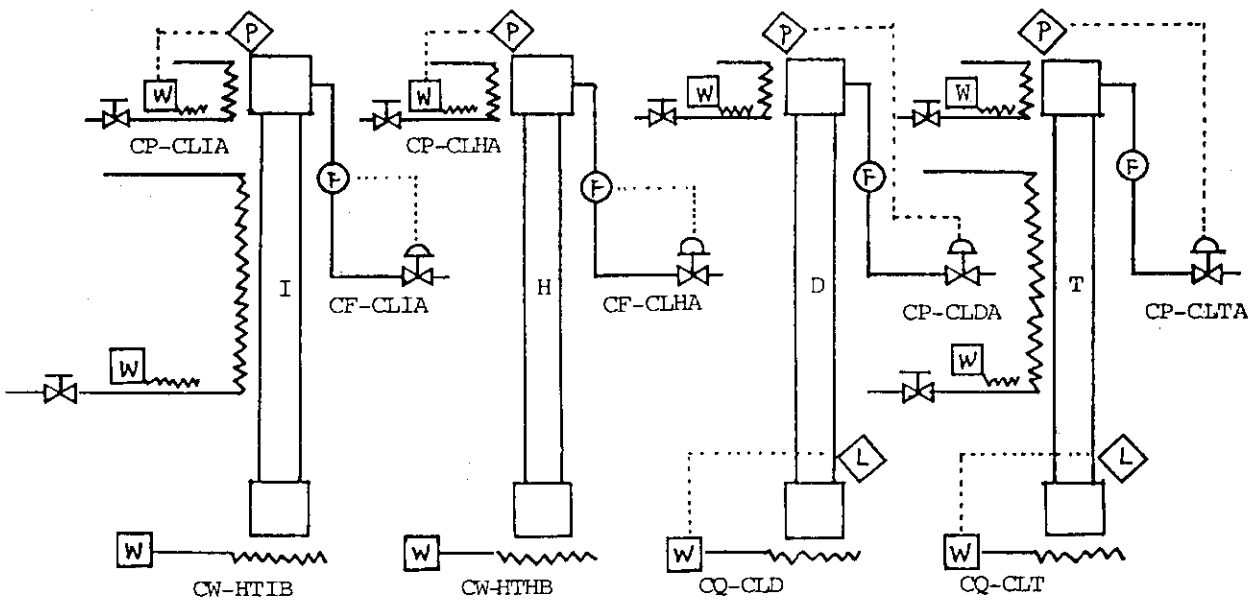
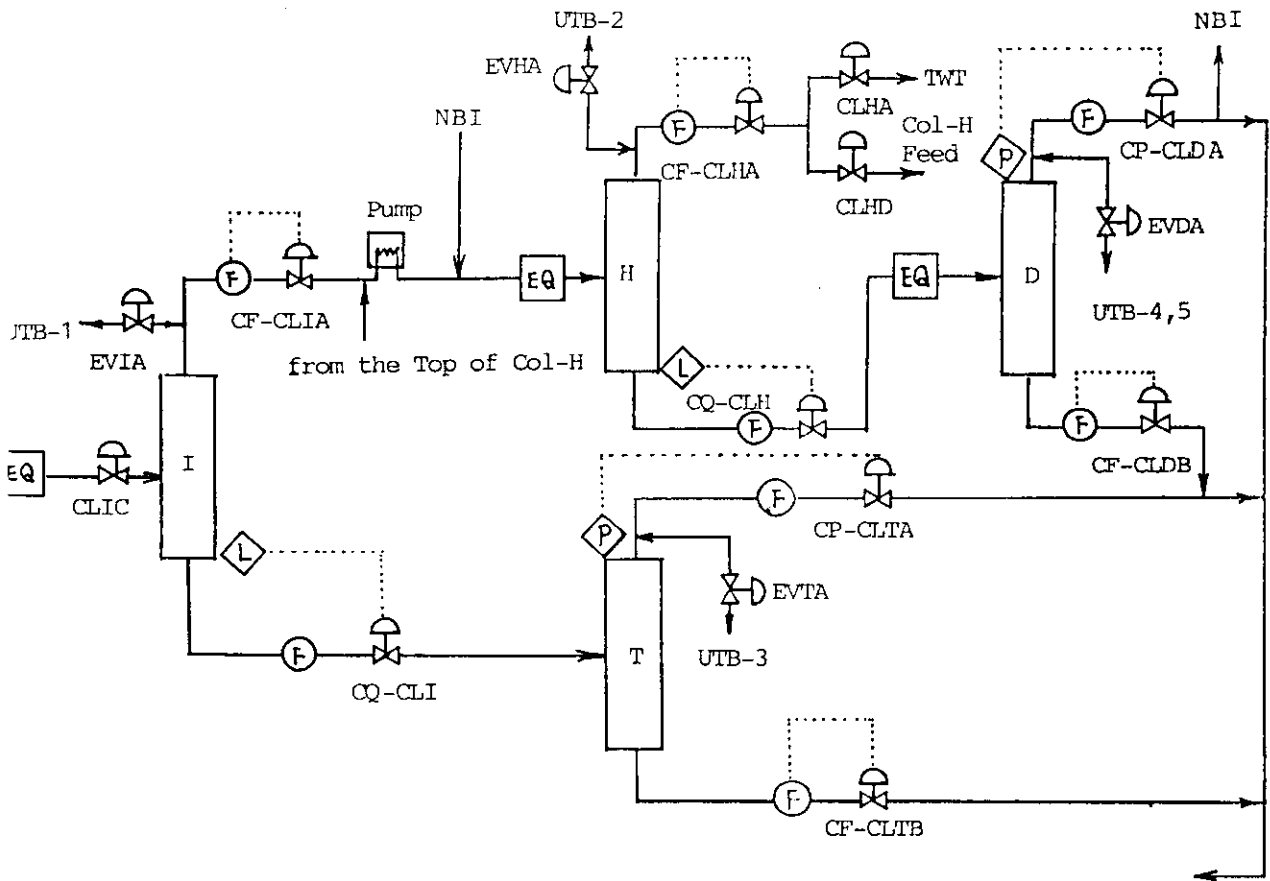

Fig. 2.5 Diagrams of flow and control in the ISS system.

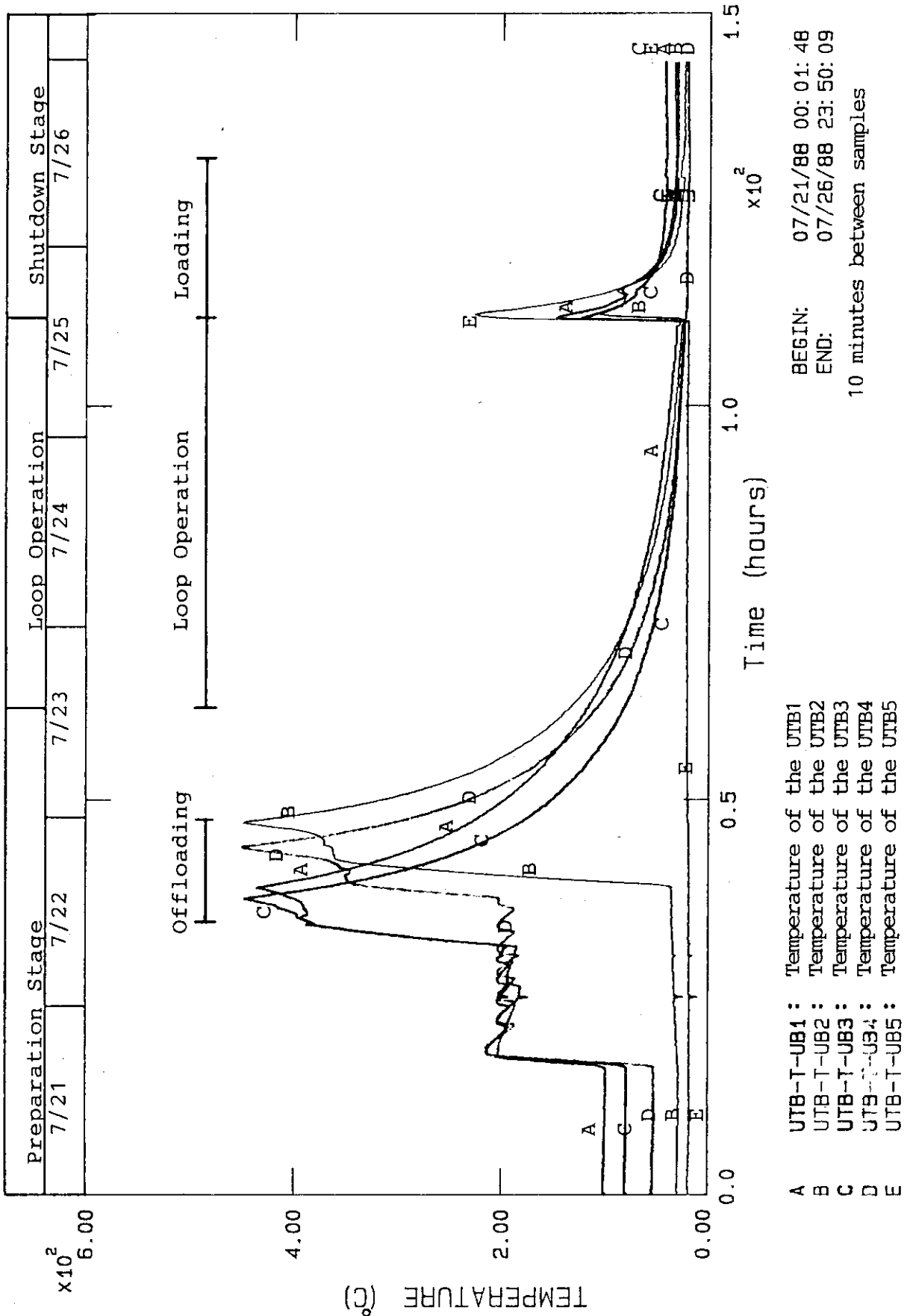

Fig. 3.1 Temperature of the UTB's during the operation.

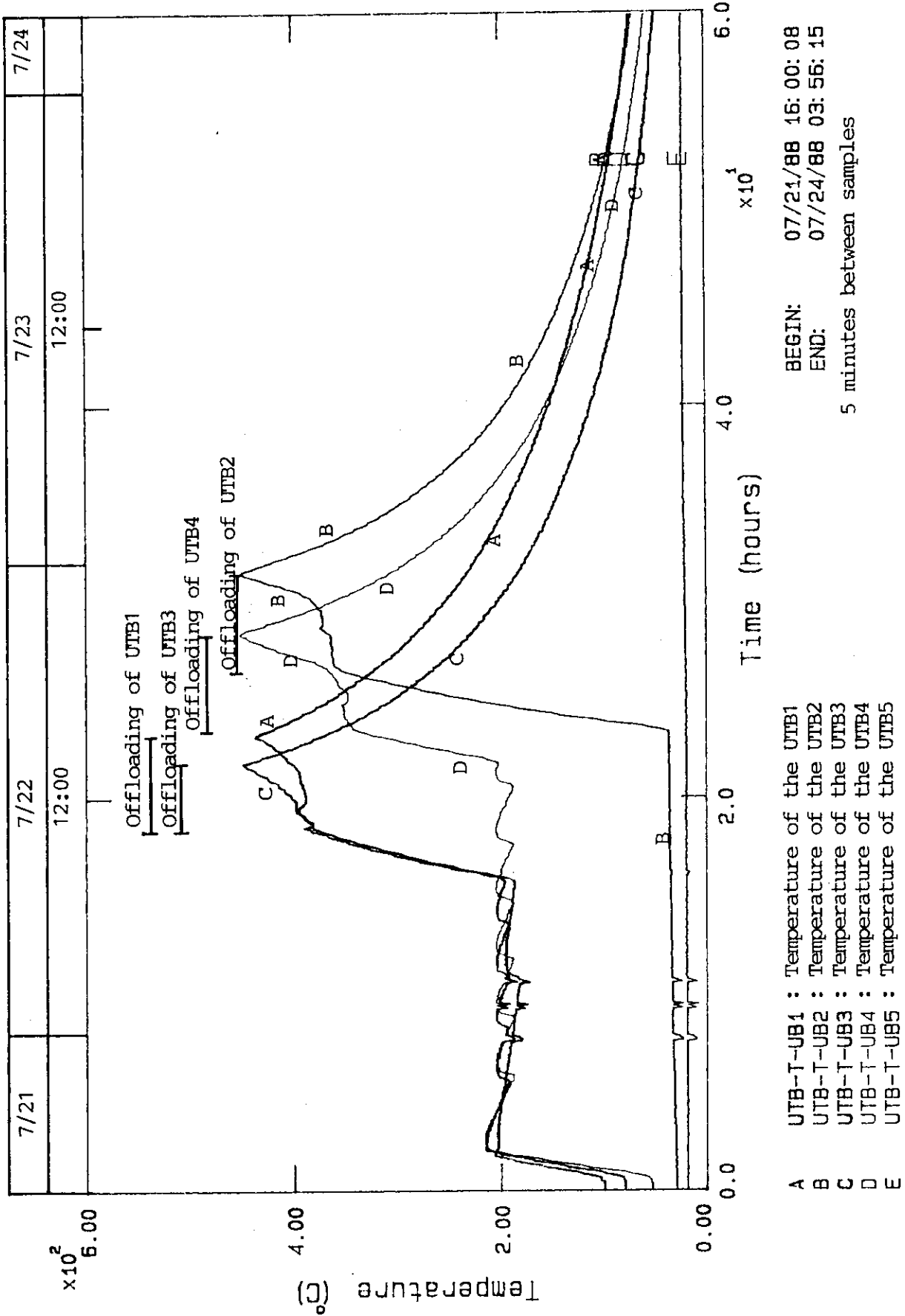
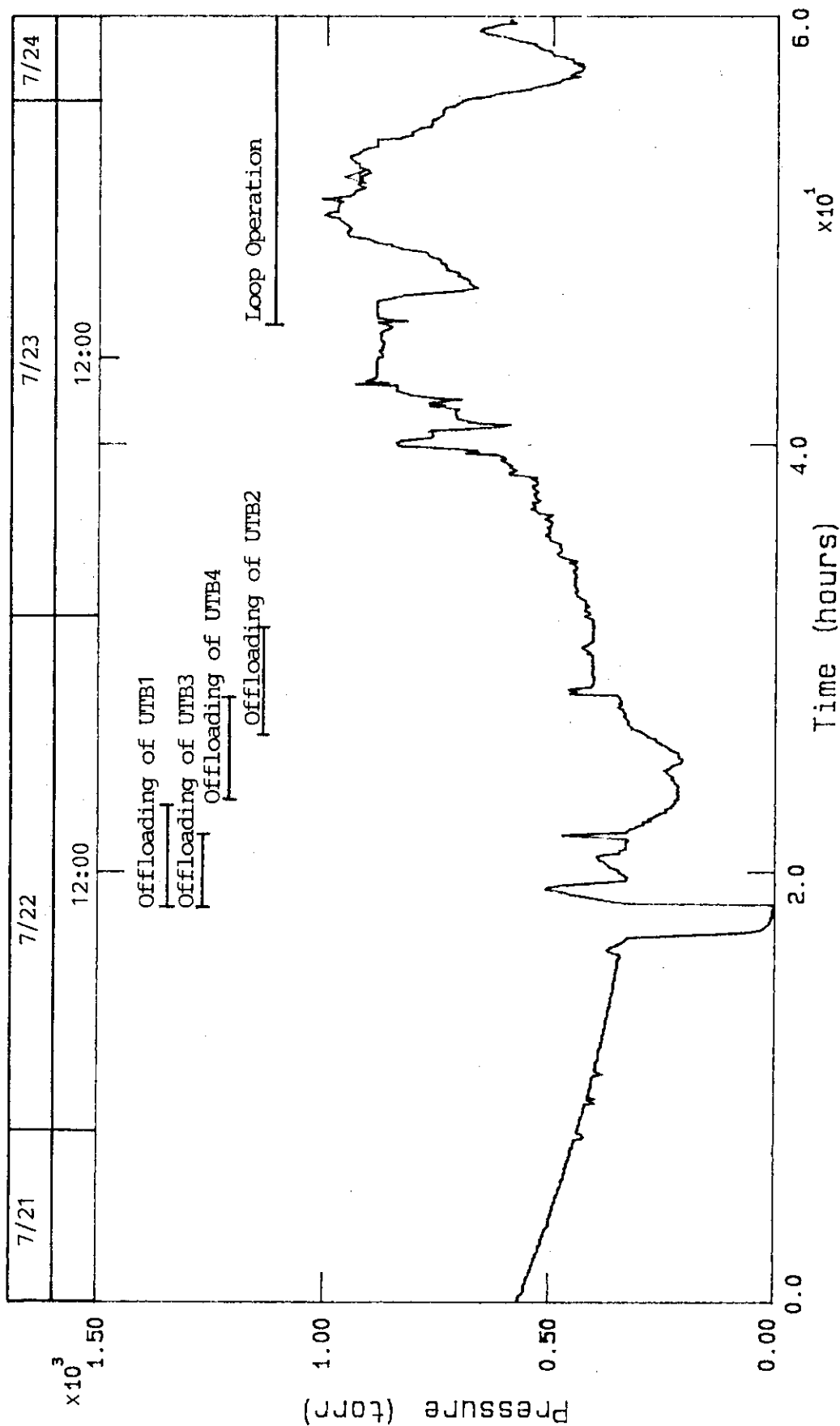

Fig. 3.2 Temperature of the UTB's during the offloading of the process gas to the ISS system.



A ISS-P-CLIA : Pressure in the column I of ISS
 BEGIN: 07/21/88 16:00:08
 END: 07/24/88 03:56:15
 5 minutes between samples

Fig. 3.3 Pressure of the column I during the loading of the process gas from UTB-1.

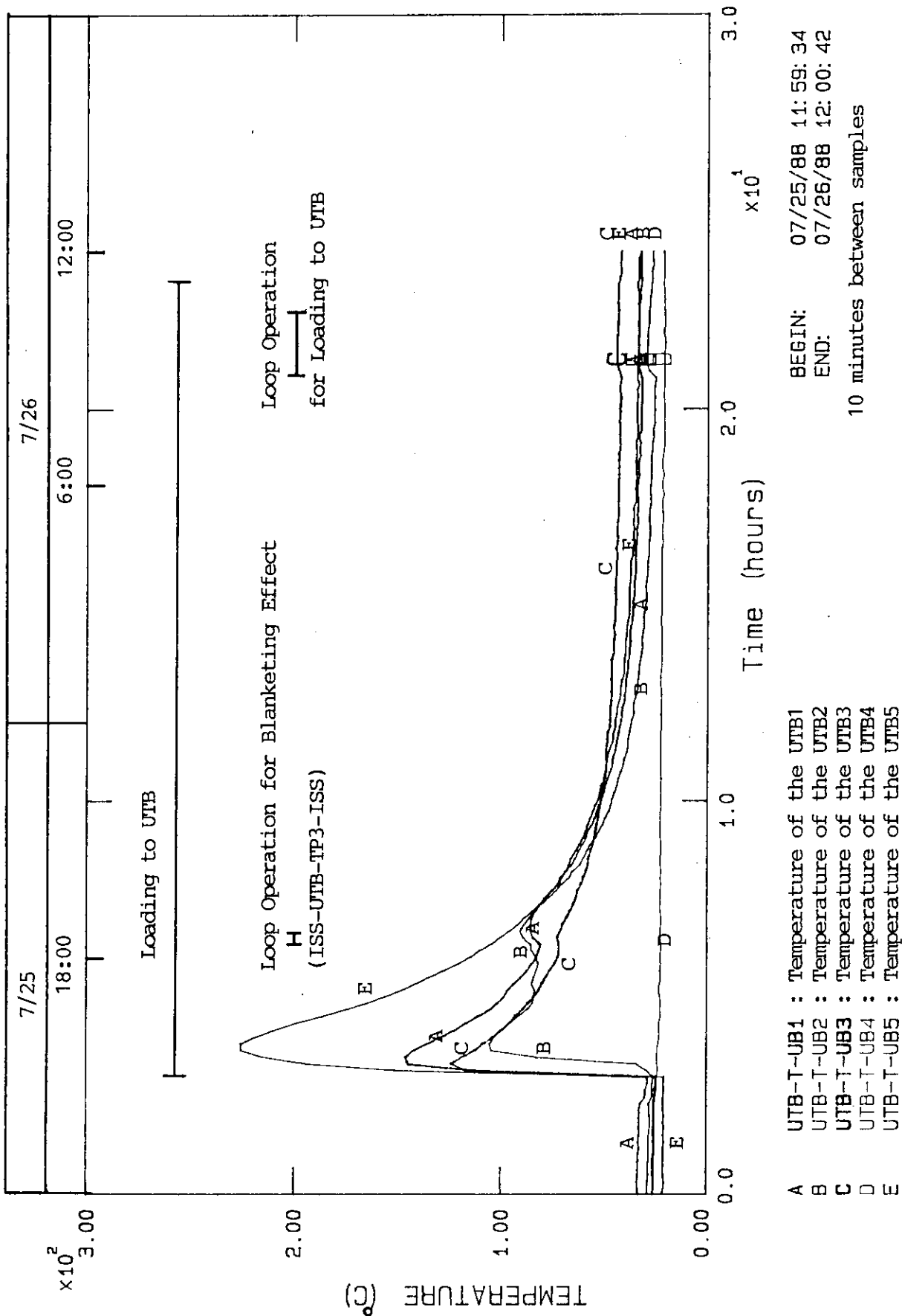
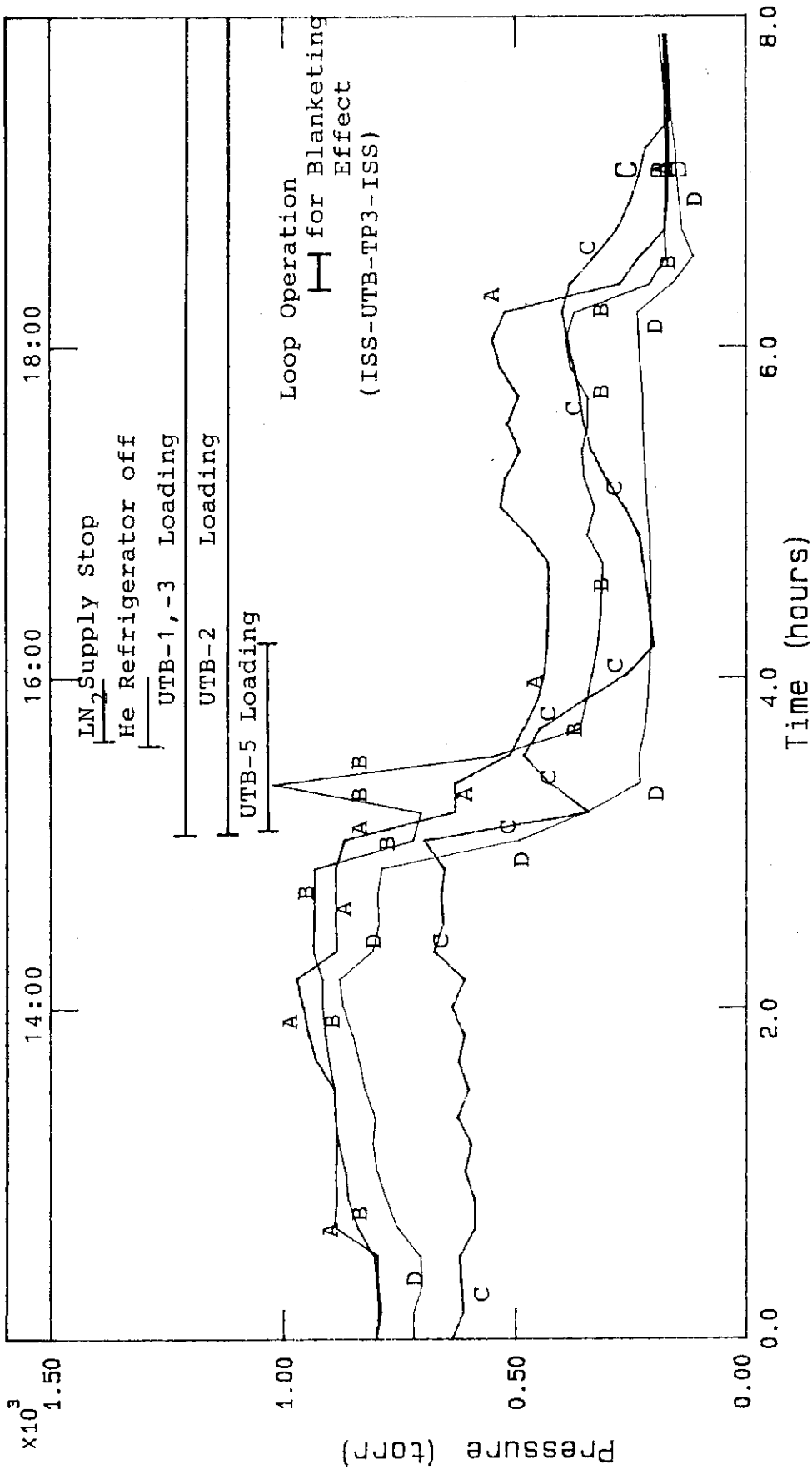

Fig. 3.4 Temperature of the UTB's during the loading of the process gas from the ISS columns.



A ISS-P-CLIA: Pressure in the column I
 B ISS-P-CLHA: Pressure in the column H
 C ISS-P-CLDA: Pressure in the column D
 D ISS-P-CLTA: Pressure in the column T

BEGIN: 07/25/88 12:00:36
 END: 07/25/88 19:53:43
 10 minutes between samples

Fig. 3.5 Pressure of the ISS columns during the offloading of the process gas to the UTB's.

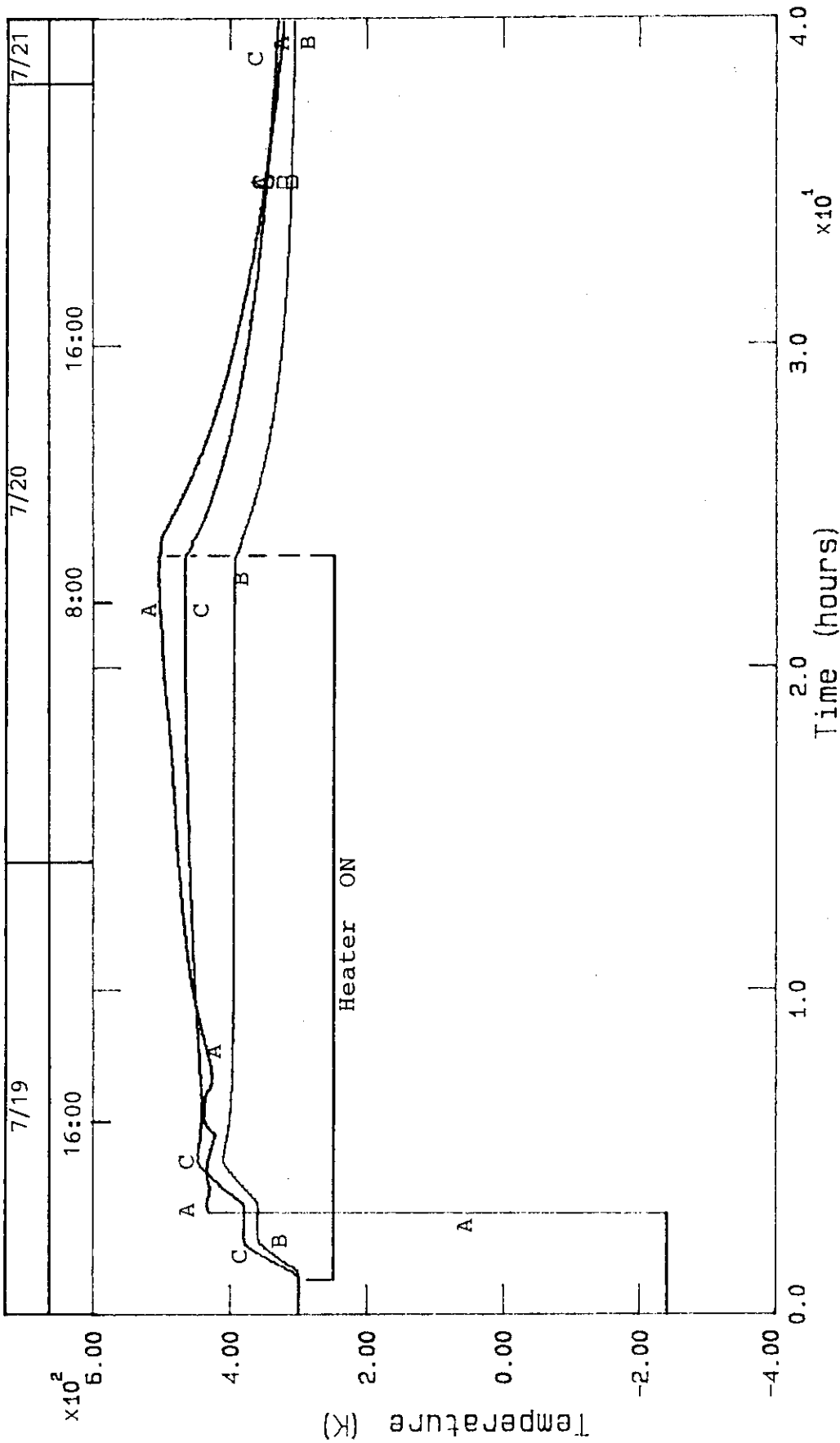

A FCU-T-CR1 : at the catalytic reactor 1 of the FCU BEGIN: 07/19/88 10:00:43
 B FCU-T-MSB1 : at the molecular sieve bed 1 of the FCU END: 07/21/88 01:58:04
 C FCU-T-MSB4 : at the molecular sieve bed 4 of the FCU(NBI) 2 minutes between samples

Fig. 3.6(a) Temperature of CR1, MSB1 and MSB4 in the FCU system during the operation.

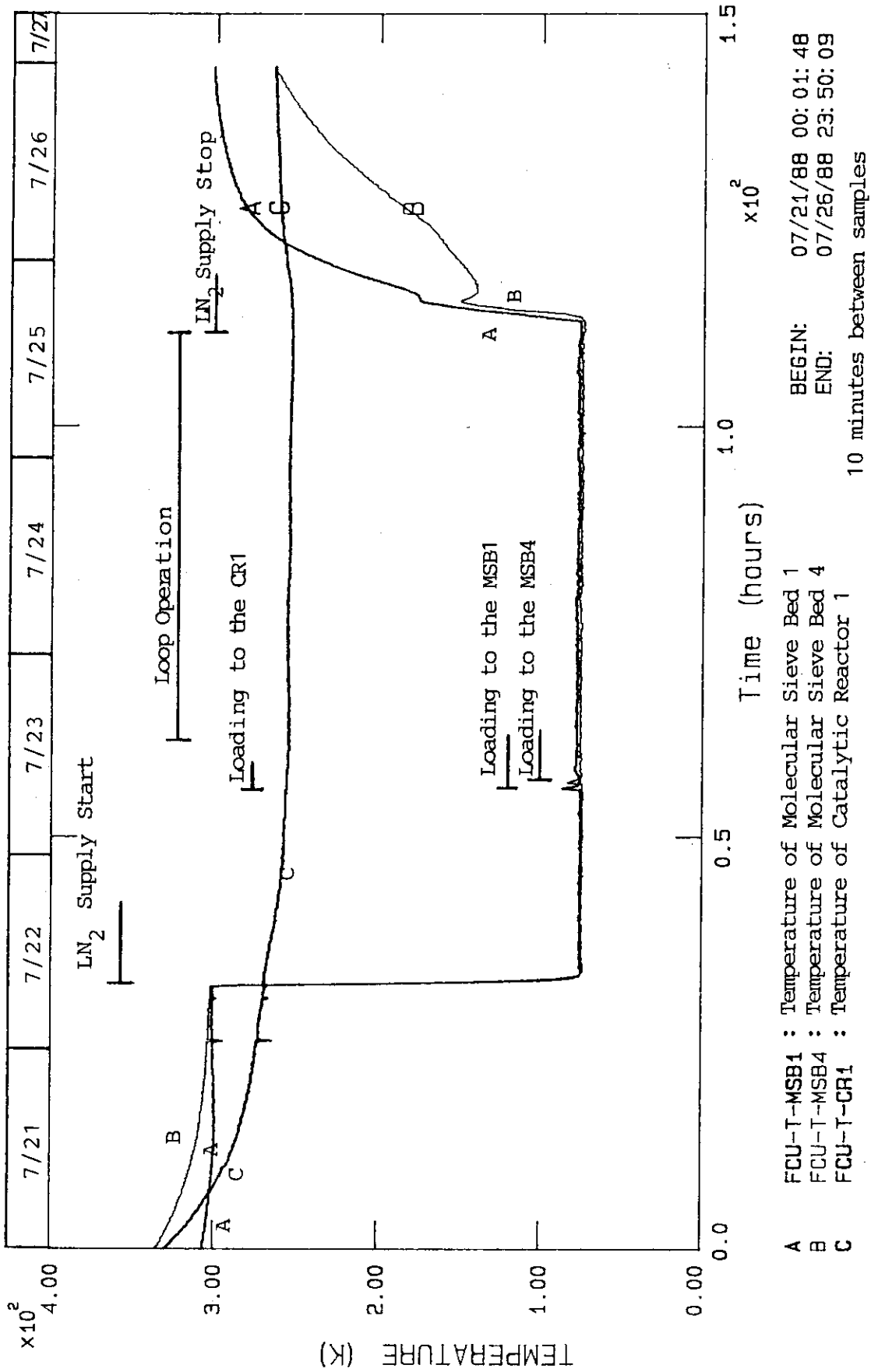

Fig. 3.6(b) Temperature of CR1, MSB1 and MSB4 in the FCU system during the operation.

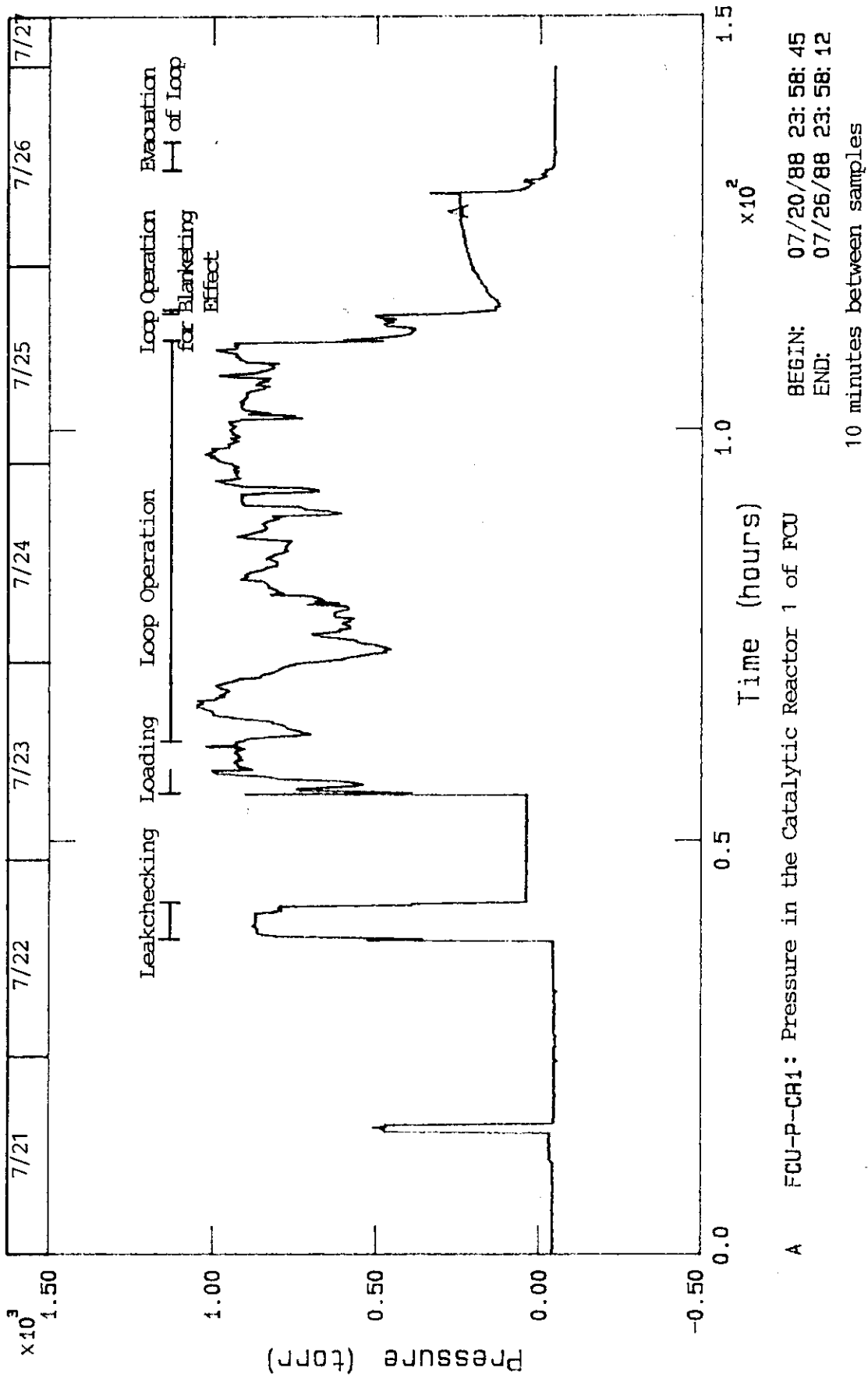
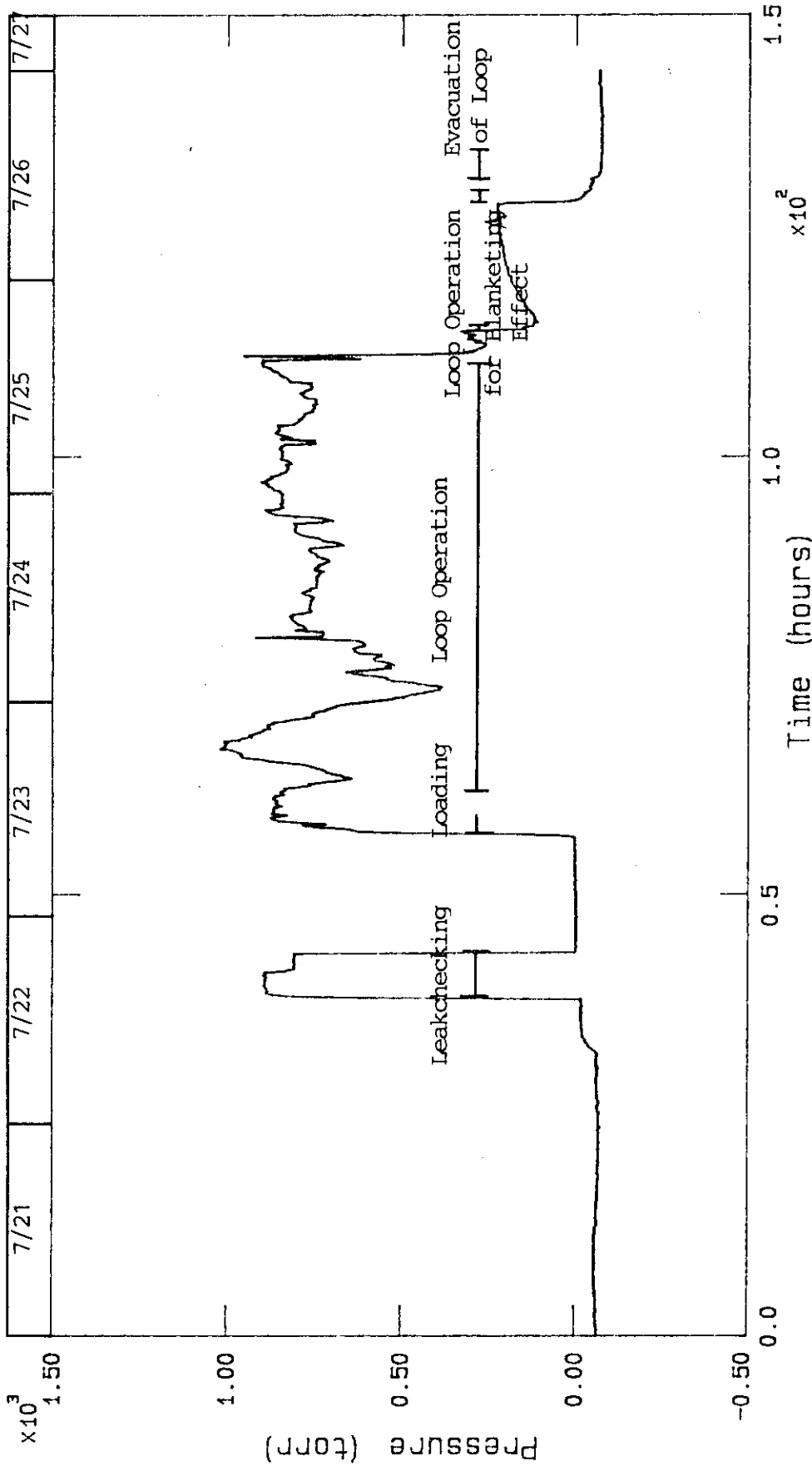

Fig. 3.7(a) Pressure of CR1 in the FCU system.



A FCU-P-MSB4 : Pressure in the Molecular Sieve Bed 4
of FCU(NBI)

BEGIN: 07/20/88 23: 58: 45
END: 07/26/88 23: 58: 12
10 minutes between samples

Fig. 3.7(b) Pressure of MSB4 in the FCU system.

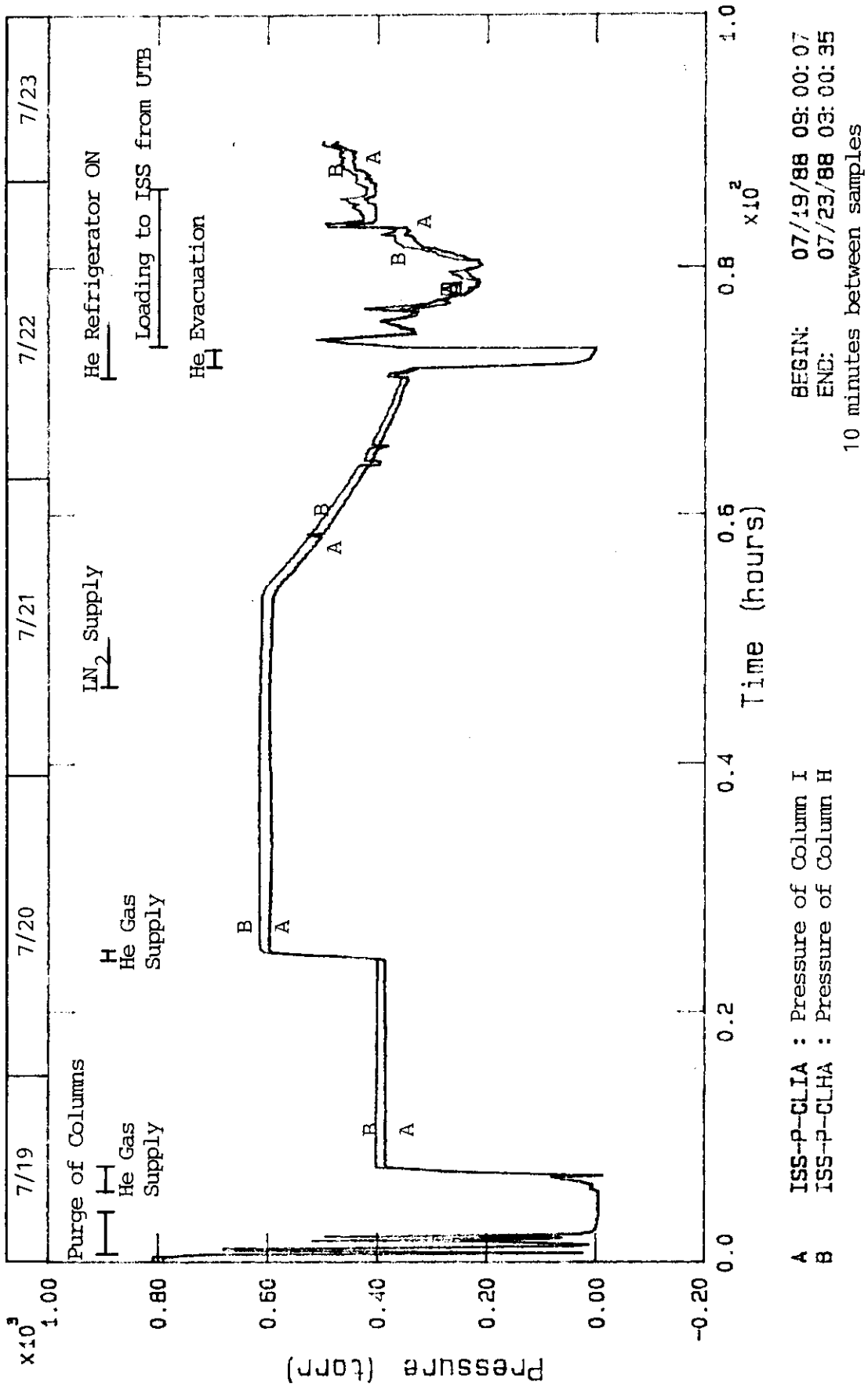
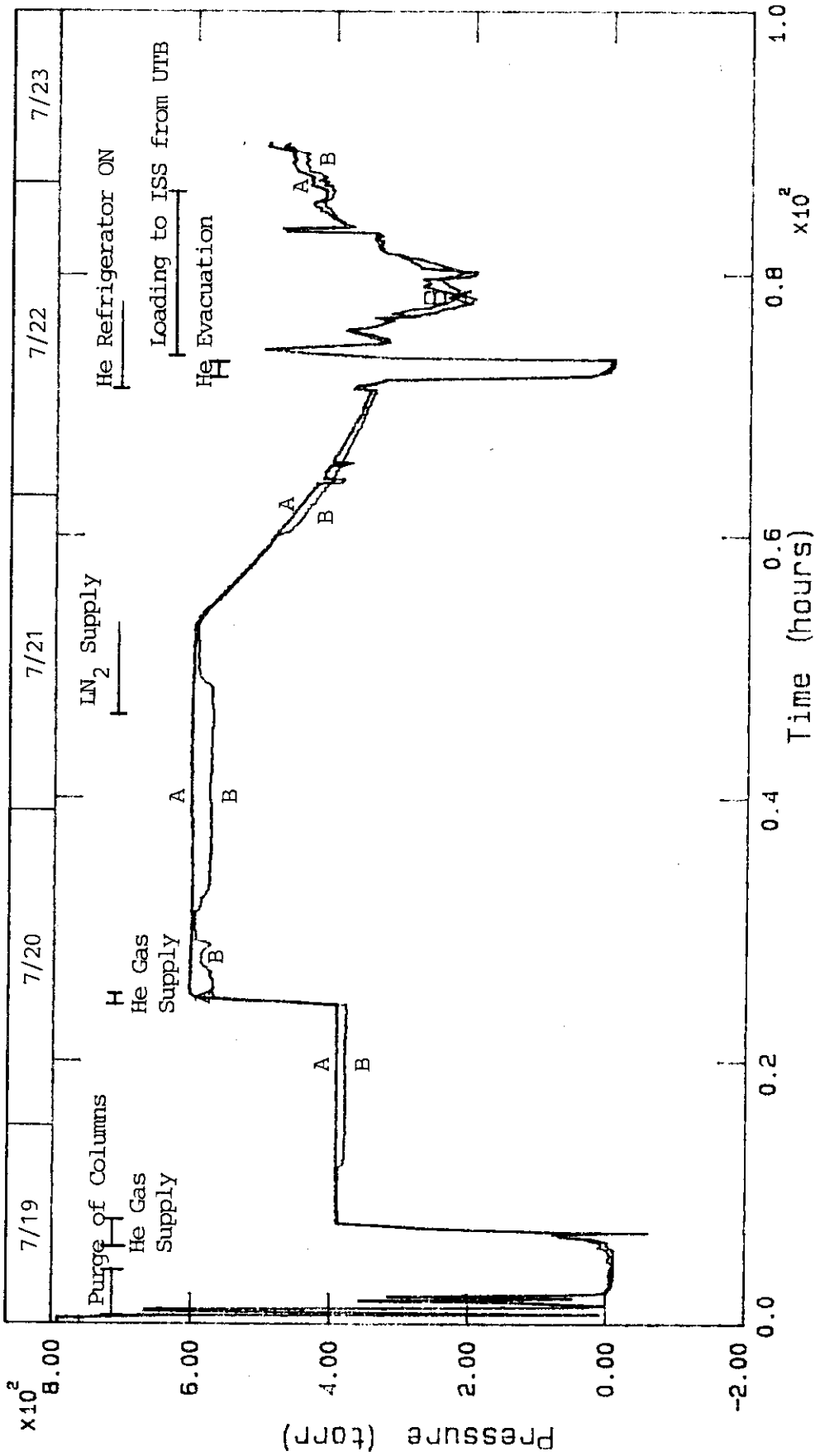
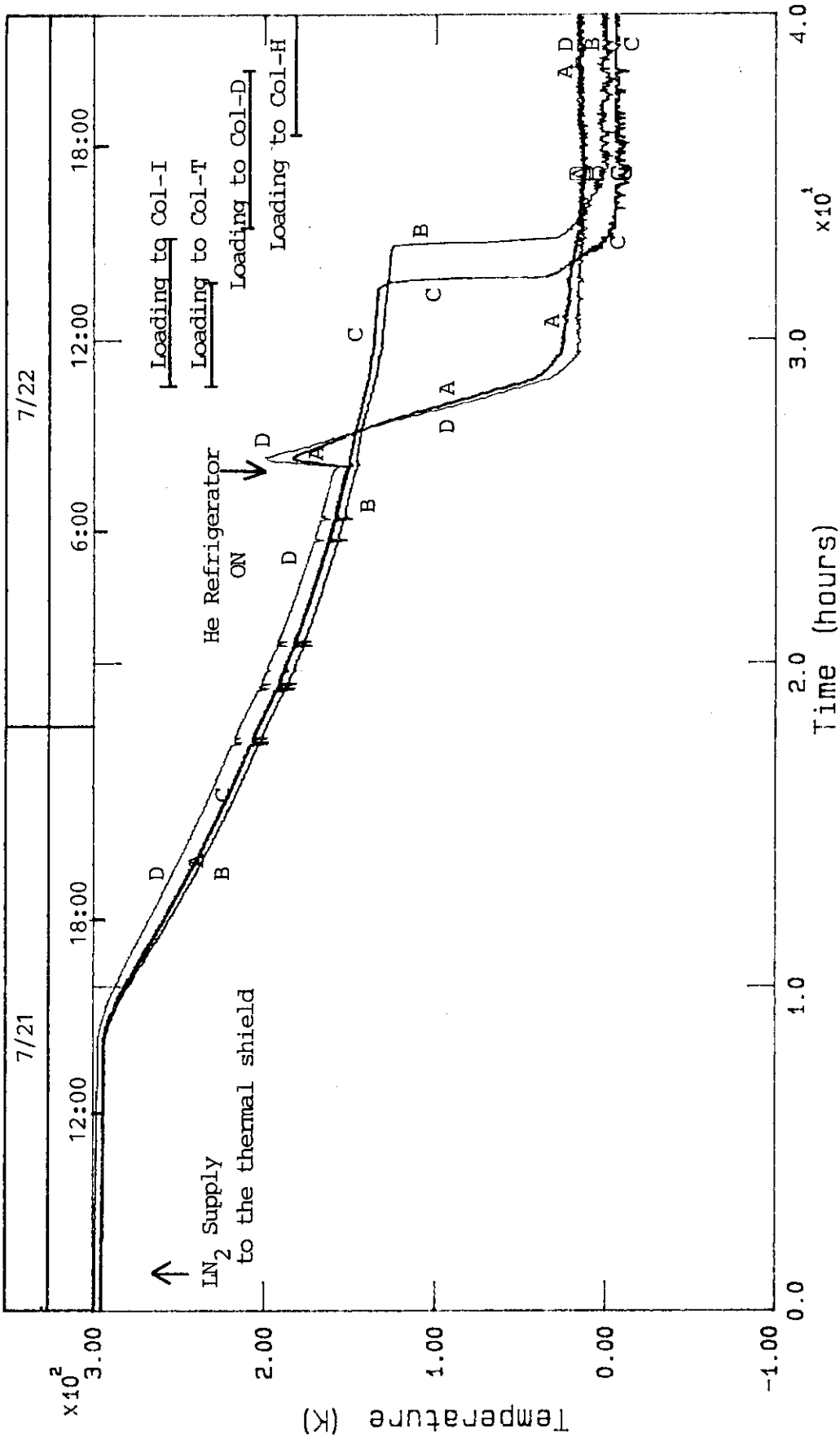

Fig. 3.8(a) Pressure of the column I and H during the preparation stage.



A ISS-P-CLDA : Pressure of Column D
B ISS-P-CLTA : Pressure of Column T
 10 minutes between samples
 BEGIN: 07/19/88 09:00:07
 END: 07/23/88 03:00:35

Fig. 3.8(b) Pressure of the column D and T during the preparation stage.



A ISS-T-CLI : Temperature of Column-I
 B ISS-T-CLH : Temperature of Column-H
 C ISS-T-CLD : Temperature of Column-D
 D ISS-T-CLT : Temperature of Column-T

BEGIN: 07/21/88 06:00:30
 END: 07/22/88 21:59:46
 2 minutes between samples

Fig. 3.9 Temperature of the ISS columns during the preparation stage.

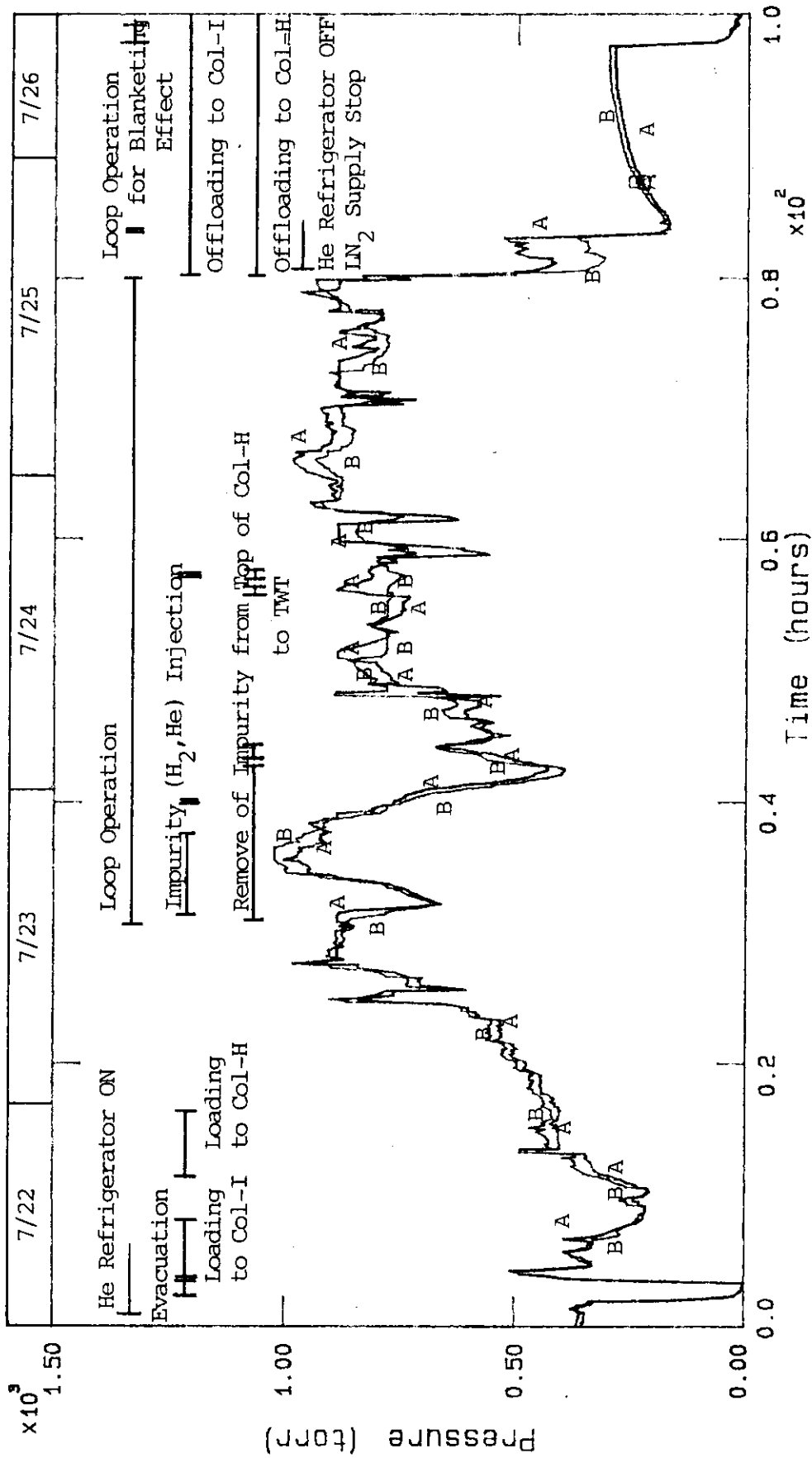

A ISS-P-CLIA : Pressure of Column I
 B ISS-P-CLHA : Pressure of Column H
 BEGIN: 07/22/88 07:01:05
 END: 07/26/88 10:55:19
 10 minutes between samples

Fig. 3.10(a) Pressure of the column I and H during the loop operation stage.

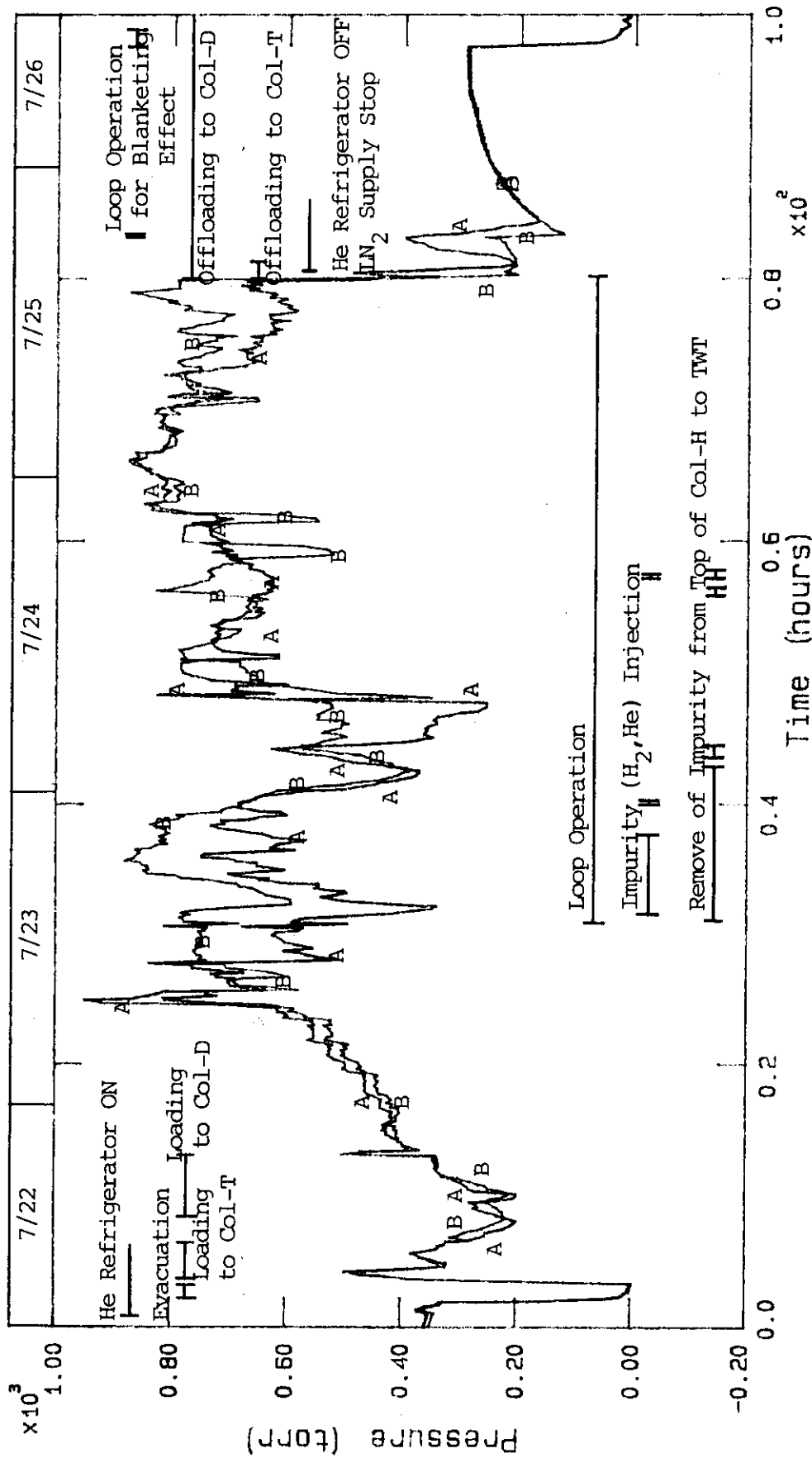

A ISS-P-CLDA : Pressure of Column D
 B ISS-P-CLTA : Pressure of Column T
 BEGIN: 07/22/88 07: 01: 05
 END: 07/26/88 10: 55: 19
 10 minutes between samples

Fig. 3.10(b) Pressure of the column D and T during the loop operation stage.

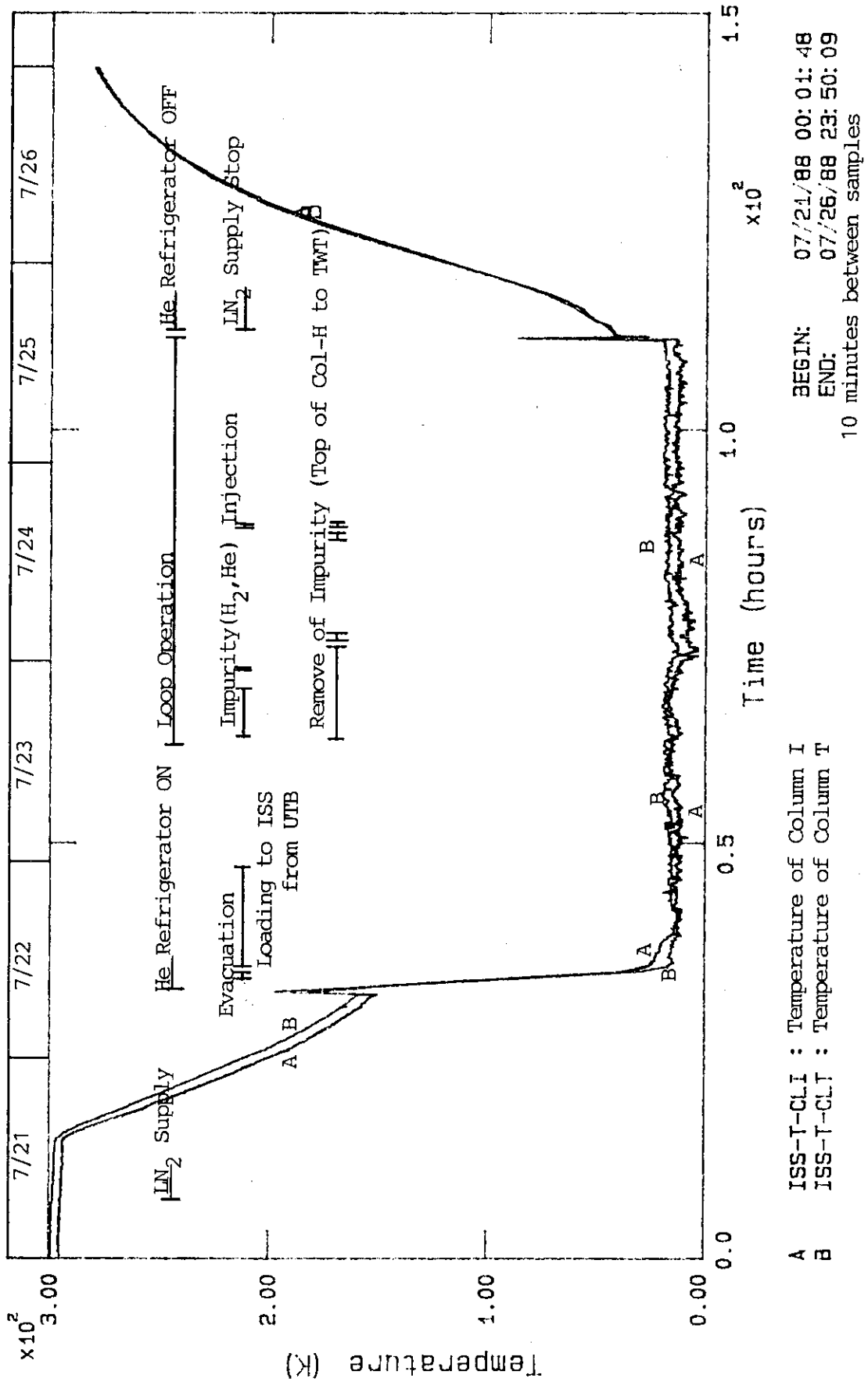
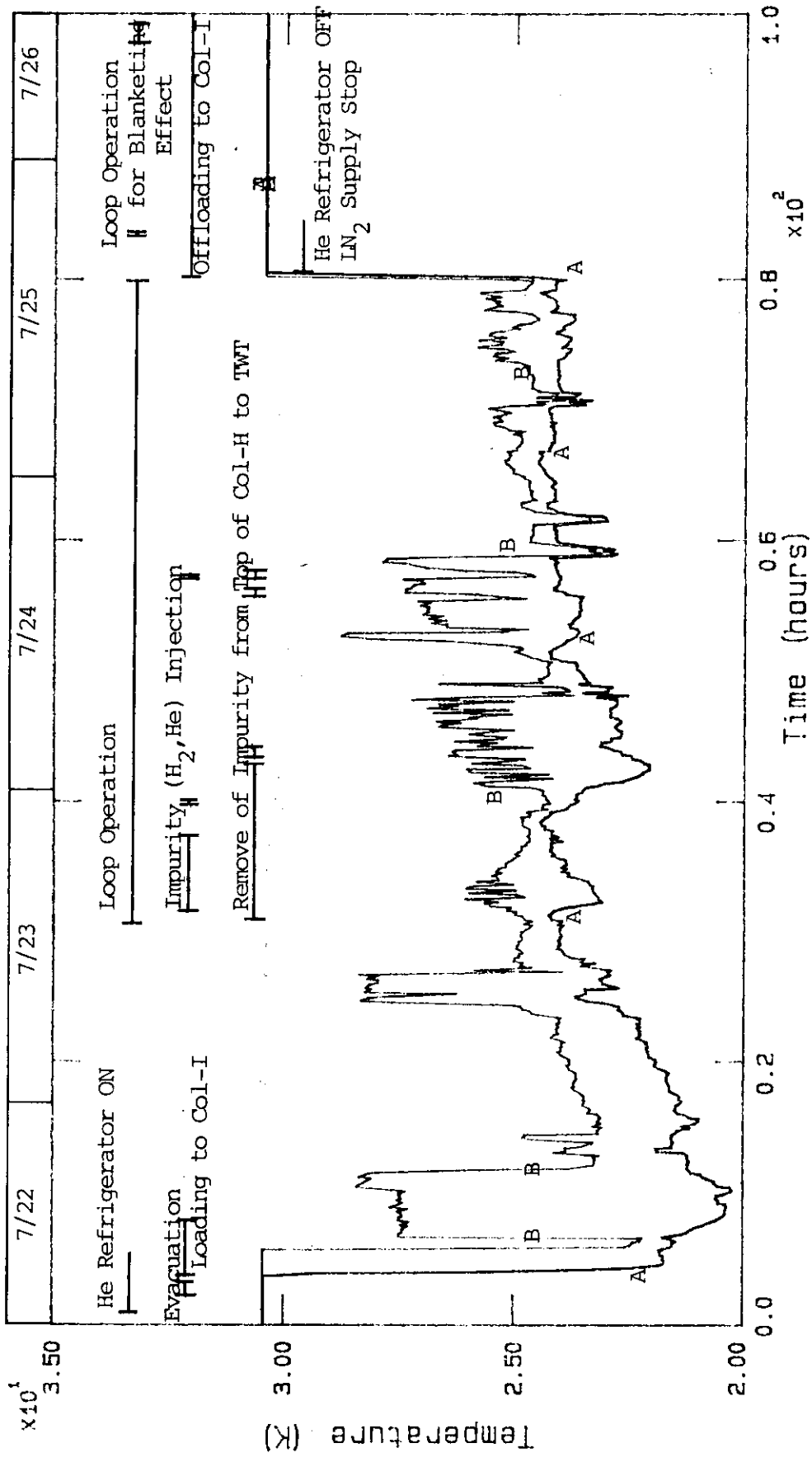
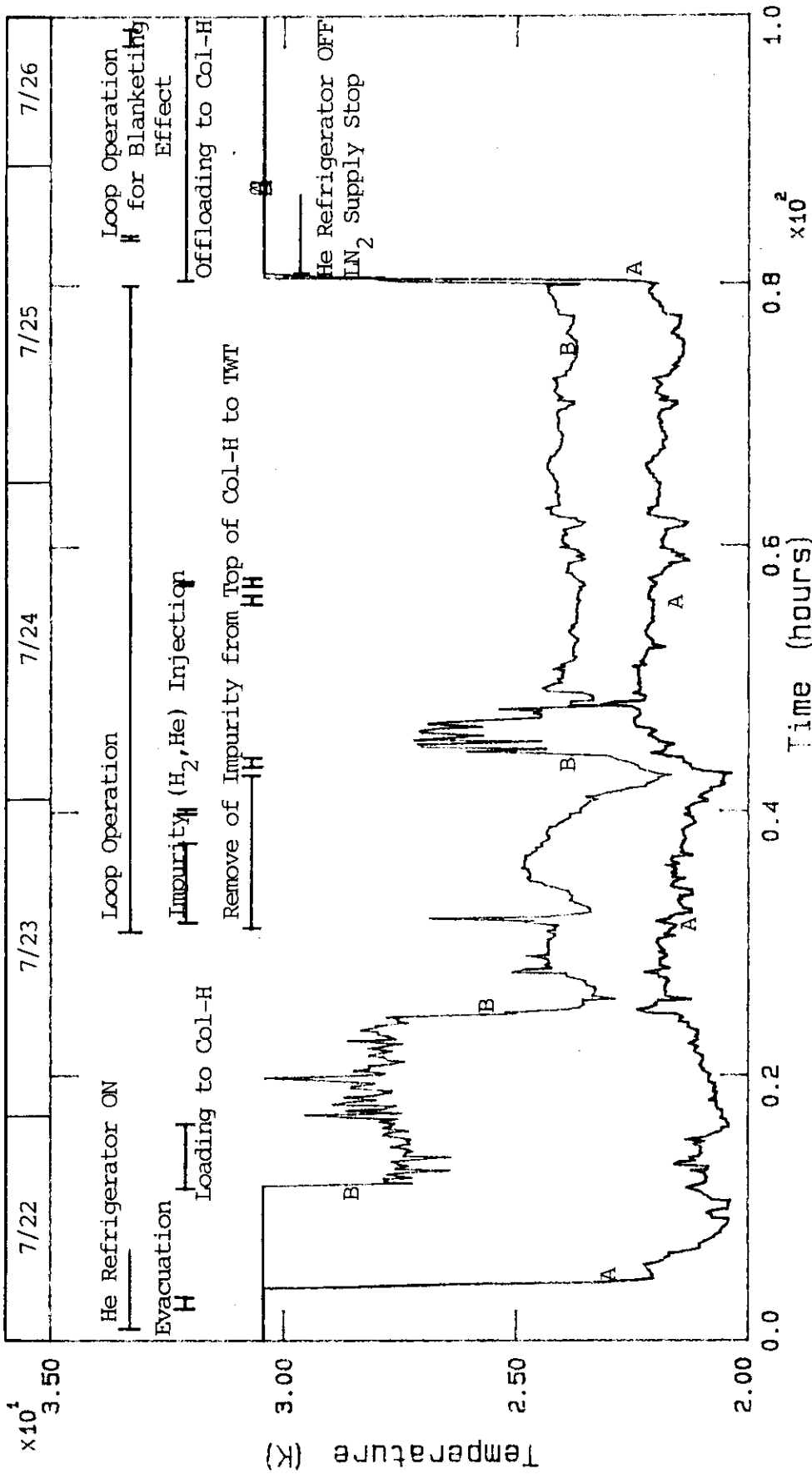

Fig. 3.11(a) Temperature of the column I and T during the loop operation stage.



A ISS-T-CLIA : Temperature at the Top of Column I BEGIN: 07/22/88 07: 01: 05
 B ISS-T-CLIB : Temperature at the Bottom of Column I END: 07/26/88 10: 55: 19
 10 minutes between samples

Fig. 3.12(a) Temperature at the top and bottom of the column I during the loop operation stage.



A ISS-T-CLHA : Temperature at the Top of Column H
 B ISS-T-CLHB : Temperature at the Bottom of Column H
 BEGIN: 07/22/88 07: 01: 05
 END: 07/26/88 10: 55: 19
 10 minutes between samples

Fig. 3.12(b) Temperature at the top and bottom of the column H during the loop operation stage.

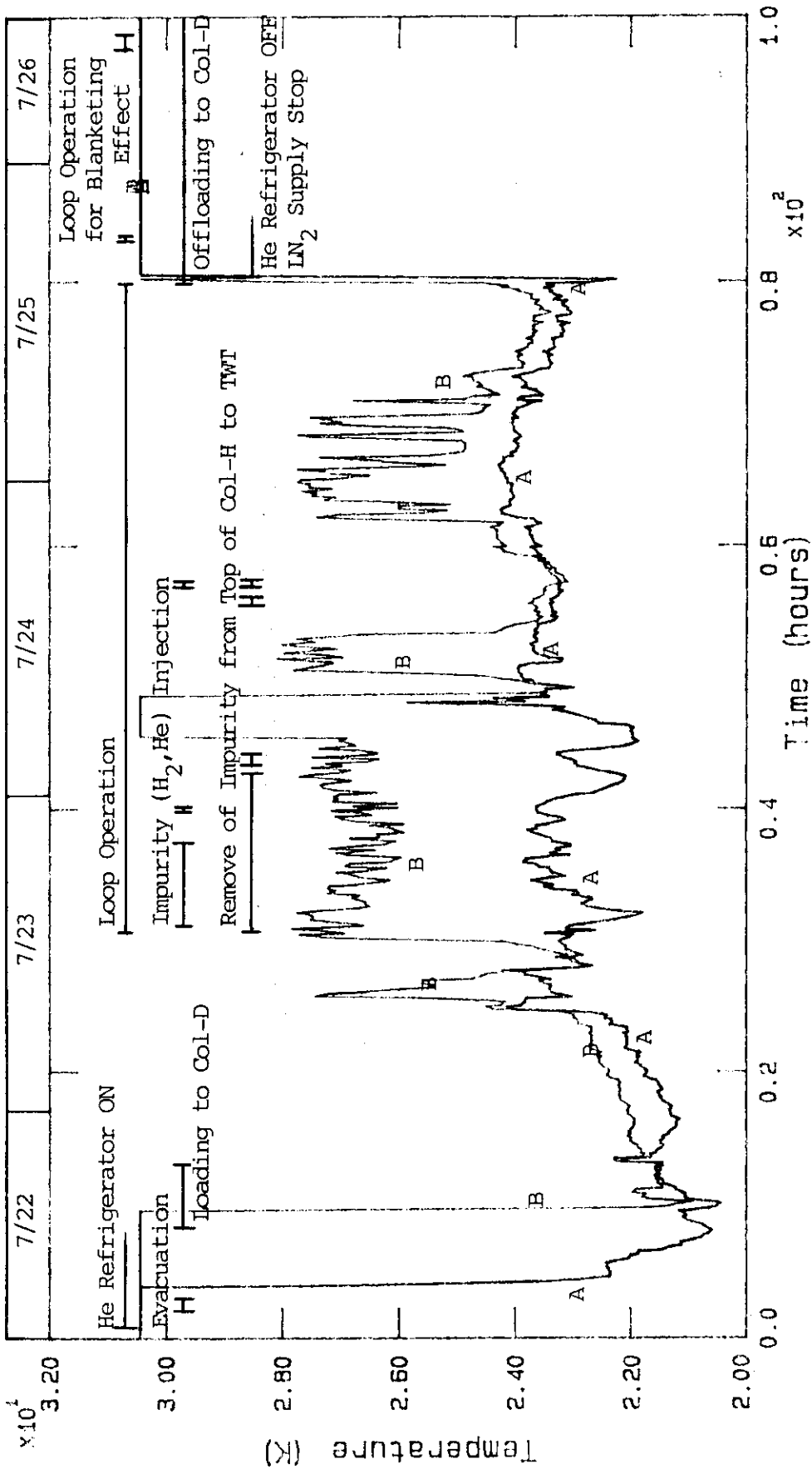

A ISS-T-CLDA: Temperature at the Top of Column D
 B ISS-T-CLDB: Temperature at the Bottom of Column D
 BEGIN: 07/22/88 07:01:05
 END: 07/26/88 10:55:19
 10 minutes between samples

Fig. 3.12(c) Temperature at the top and bottom of the column D during the loop operation stage.

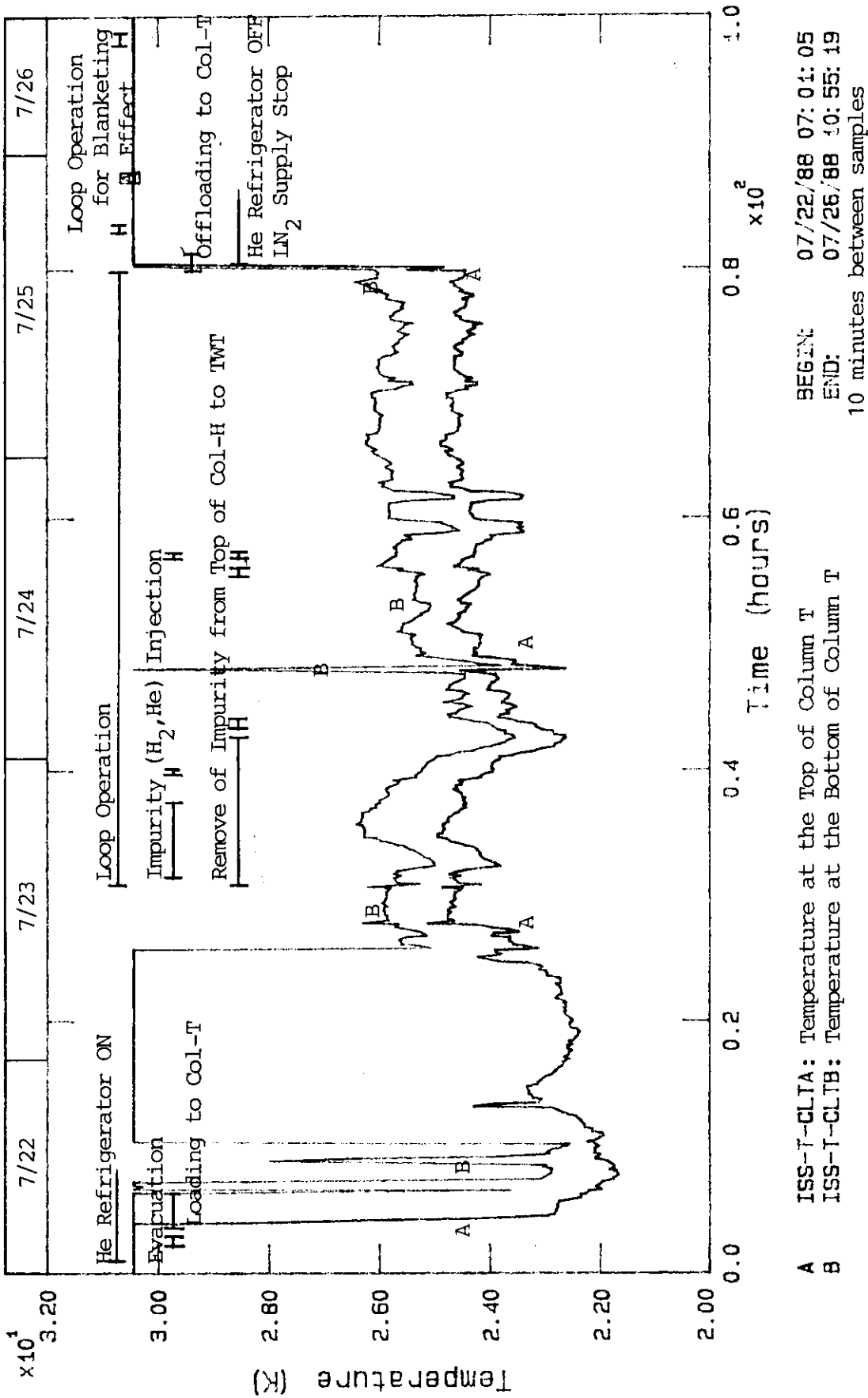
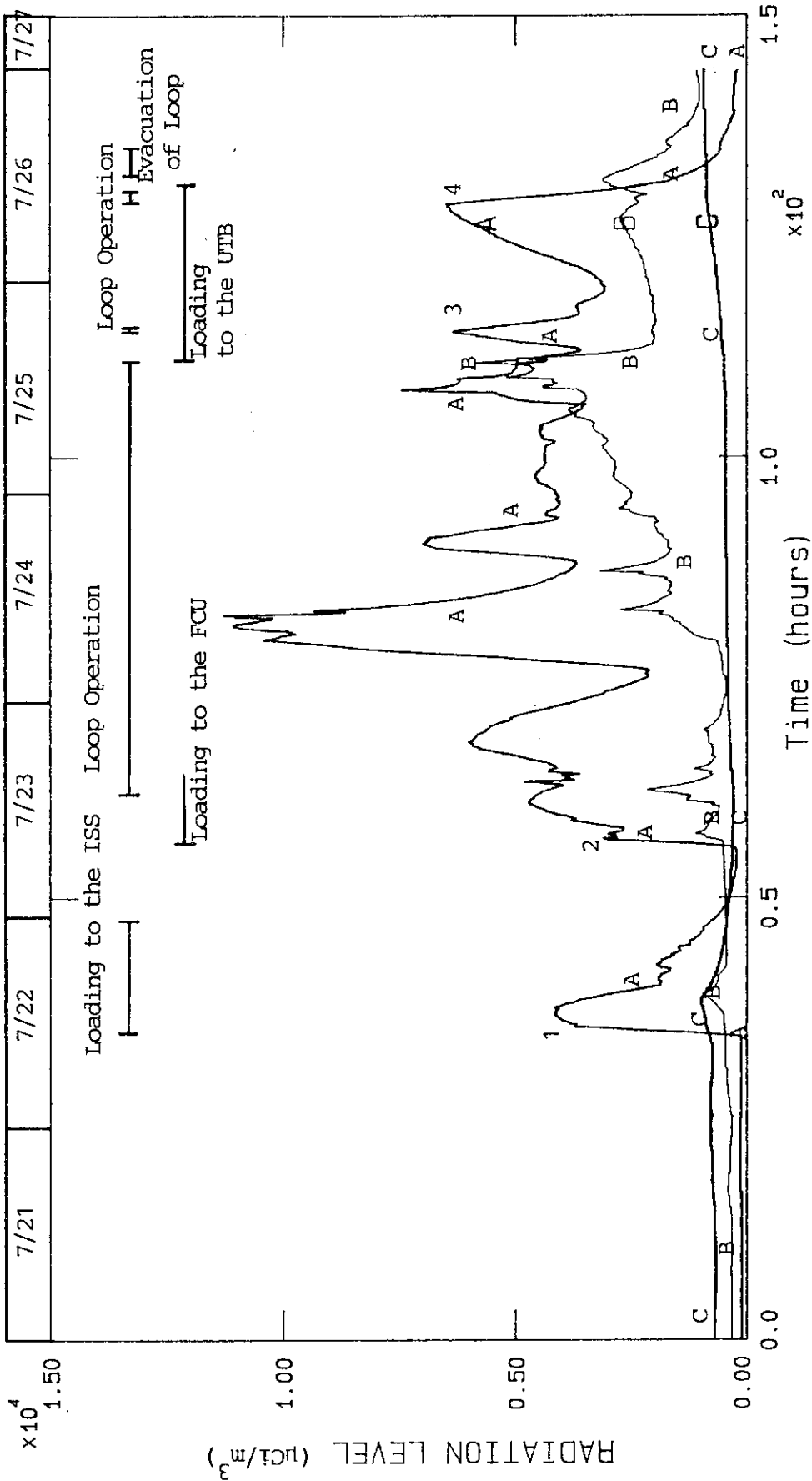
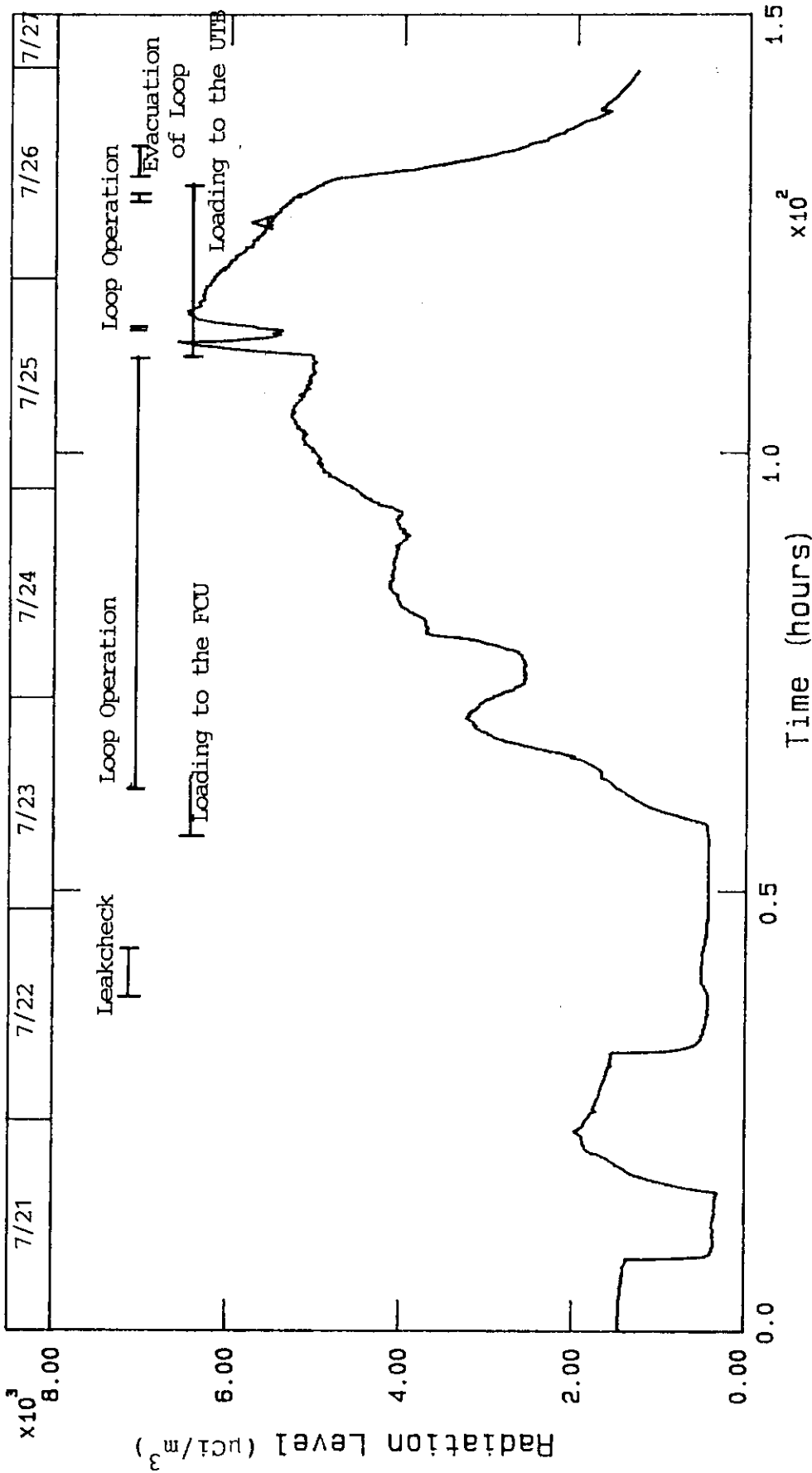

Fig. 3.12(d) Temperature at the top and bottom of the column T during the operation stage.



A ISS-RAD-6B1: Radiation Level in the Glove Box 1 of ISS BEGIN: 07/21/88 00:01:48
B ISS-RAD-6B2: Radiation Level in the Glove Box 2 of ISS END: 07/26/88 23:50:09
C ISS-RAD-6B3: Radiation Level in the Glove Box of UTB 10 minutes between samples

Fig. 3.13 Tritium radiation level in the ISS gloveboxes.



A FCU-RAD-GB1: Radiation Level in the Glove Box of FCU
 BEGIN: 07/21/88 00:01:48
 END: 07/26/88 23:50:09
 10 minutes between samples

Fig. 3.14 Tritium radiation level in the FCU glovebox.

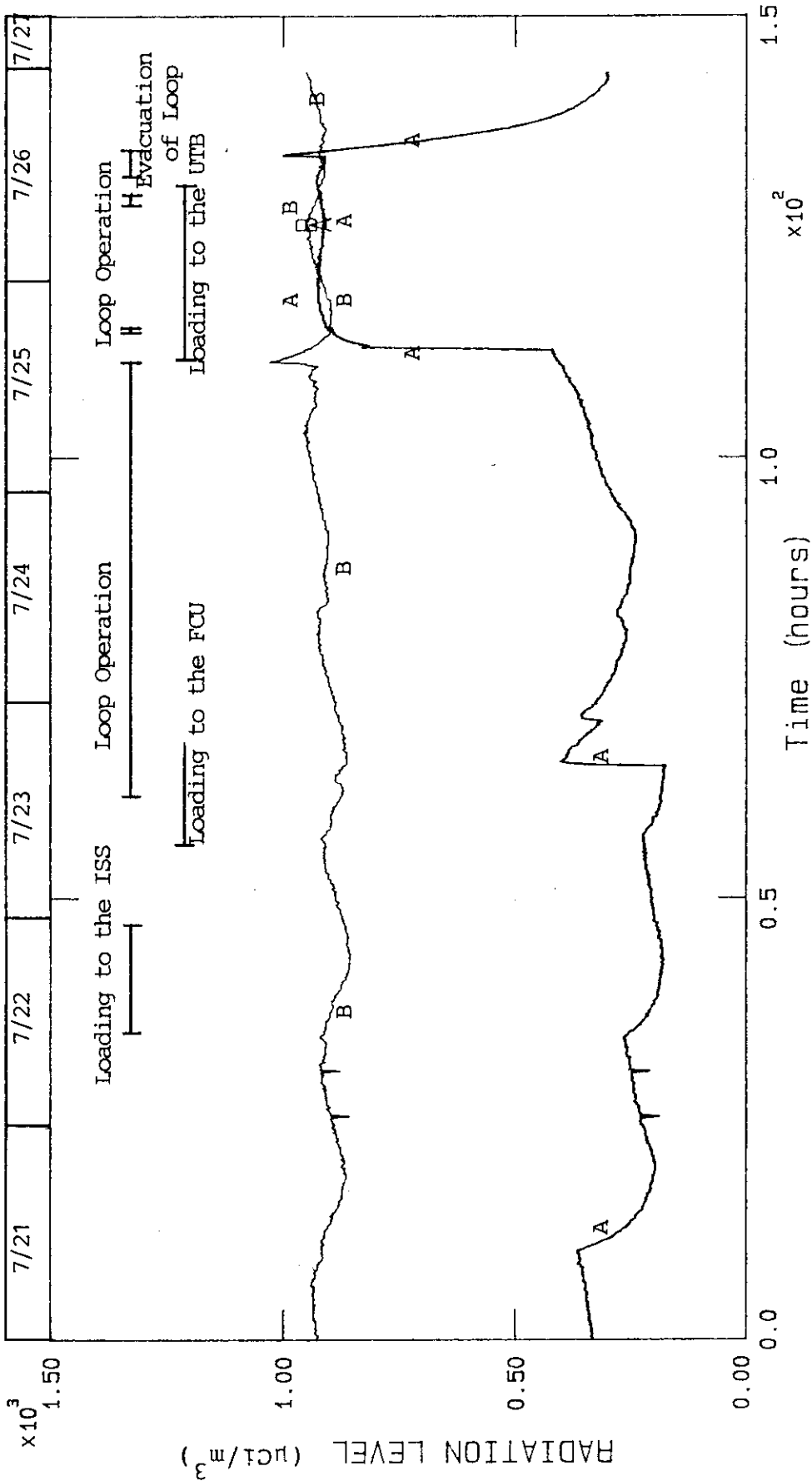

A INV-RAD-GB1 : Radiation Level in the Glovebox of LIO
 B INV-RAD-GB2 : Radiation Level in the Glovebox of INV
 BEGIN: 07/21/88 00: 01: 48
 END: 07/26/88 23: 50: 09
 10 minutes between samples

Fig. 3.15 Tritium radiation level in the LIO and INV gloveboxes.

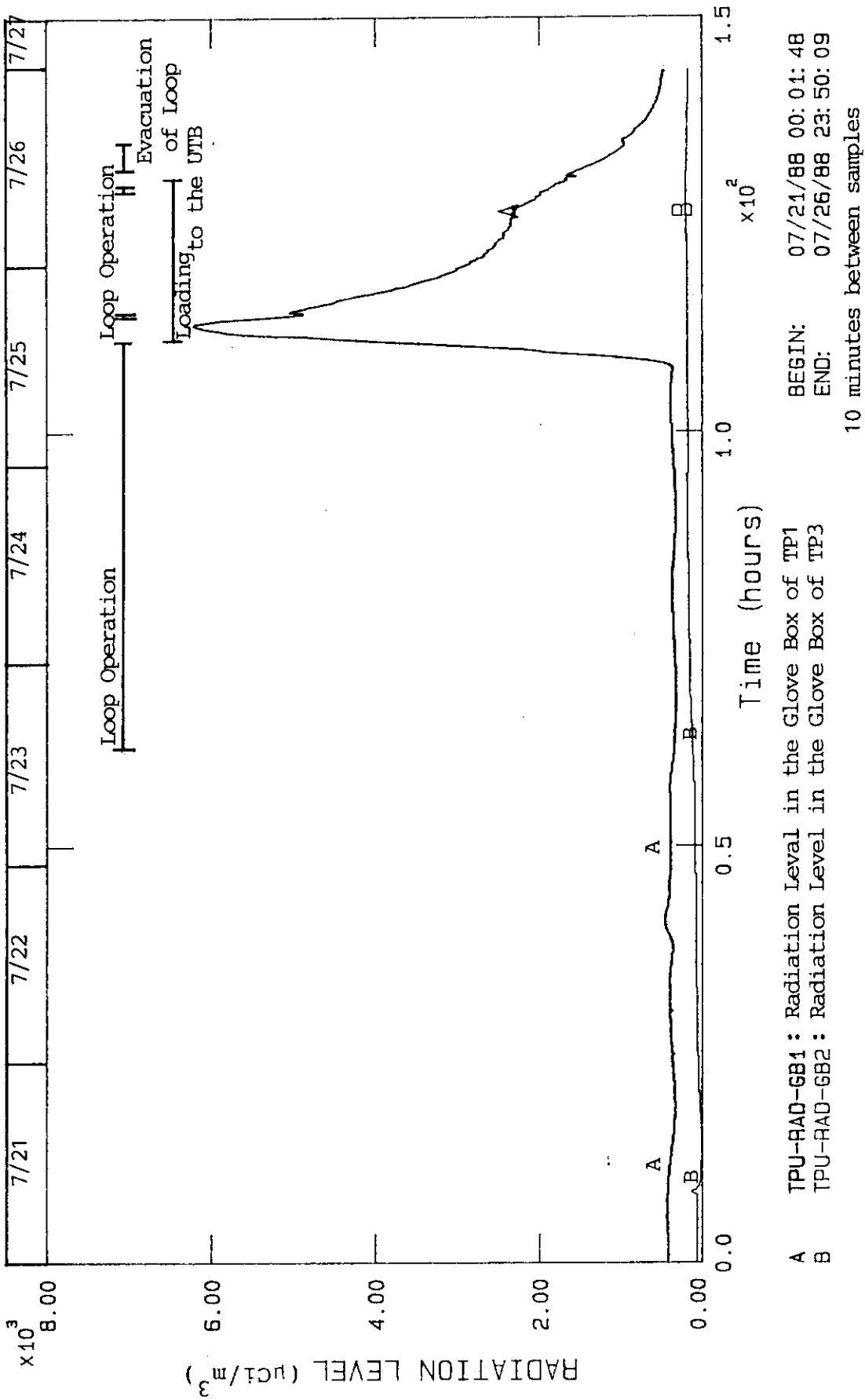

Fig. 3.16 Tritium radiation level in the TP1 and TP3 gloveboxes.

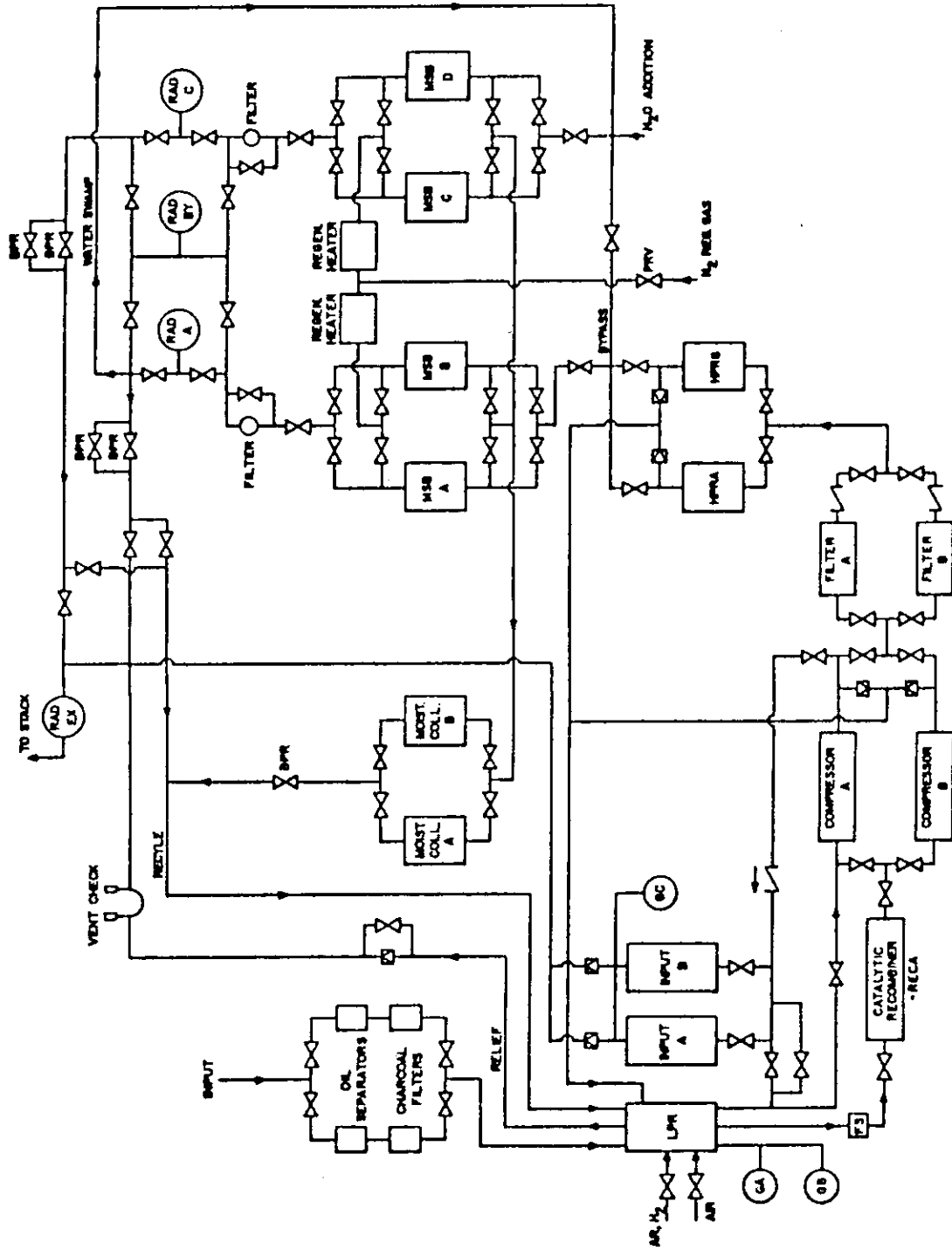
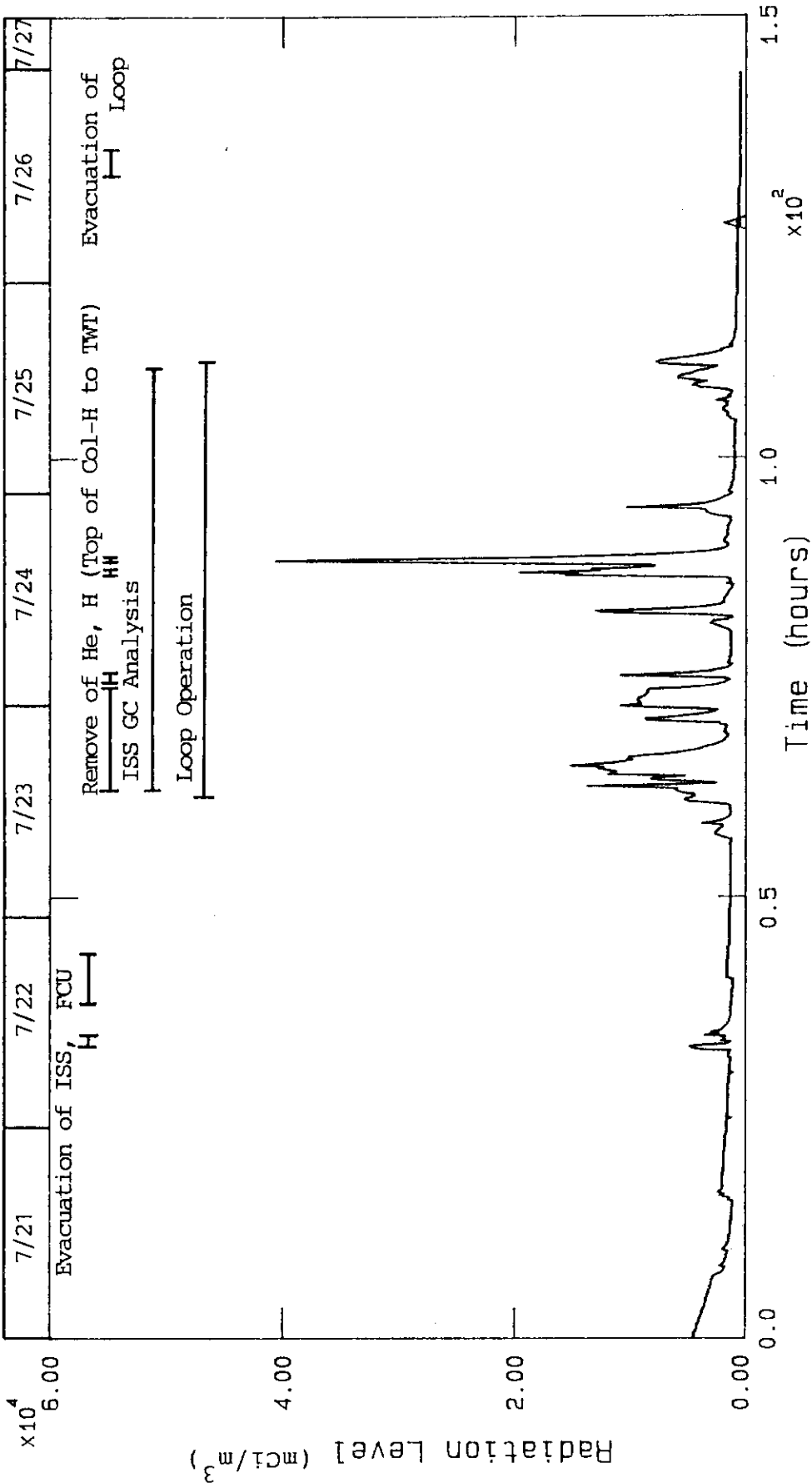
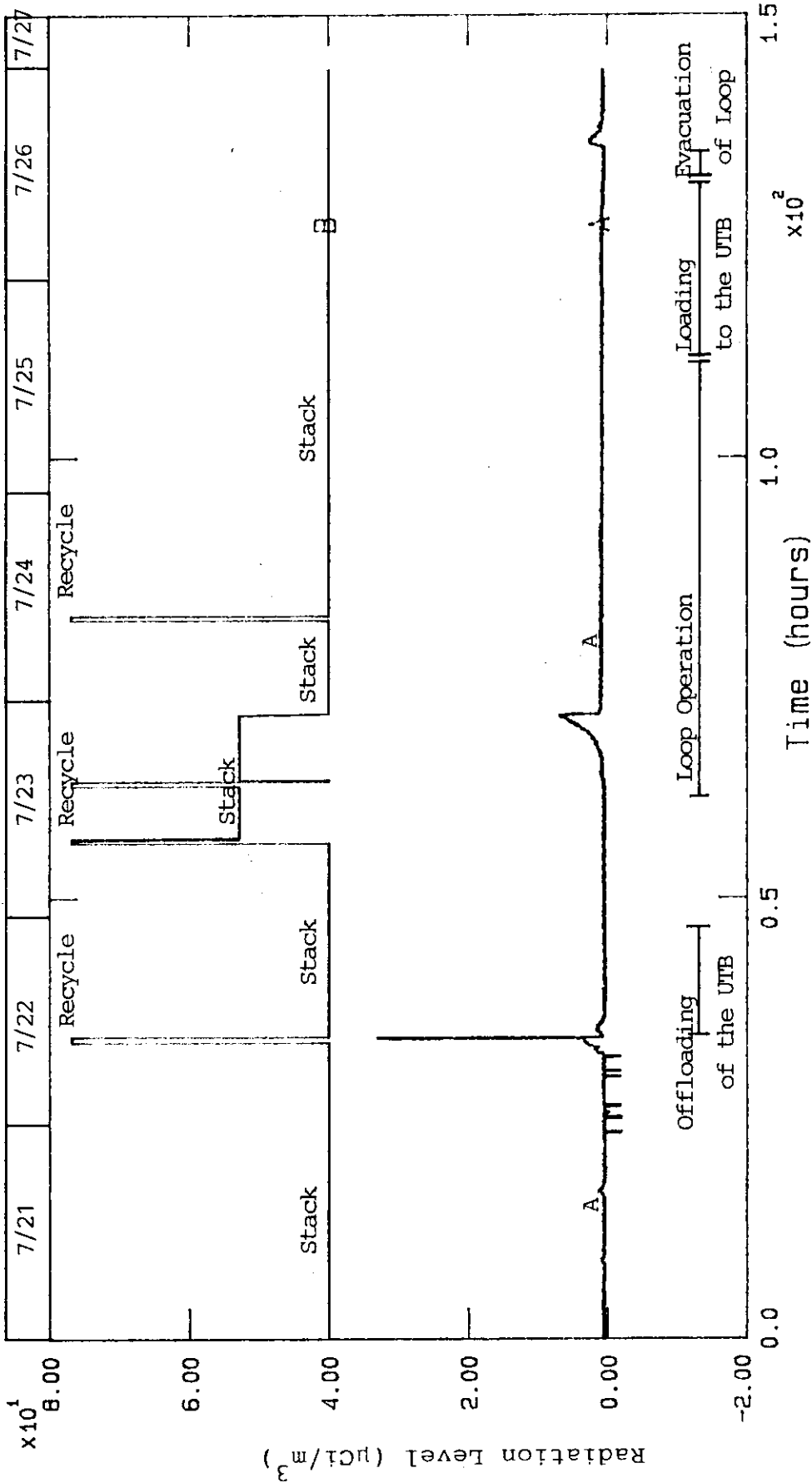

Fig. 3.17 Schematic configuration of the TWT system.



A TWT-RAD-LPR : Radiation Level in the LPR of TWT
 BEGIN: 07/21/88 00: 01: 48
 END: 07/26/88 23: 50: 09
 10 minutes between samples

Fig. 3.18 Tritium radiation level at the LPR in the TWT system.



A TWT-RAD-PMEX : Radiation Level at the exit of TWT
B TWT-STATUS : Status of the TWT
 (Stack or Recycle)

BEGIN: 07/21/88 00:01:48
END: 07/26/88 23:56:11
 10 minutes between samples

Fig. 3.19 Tritium radiation level at the exit of the TWT system.

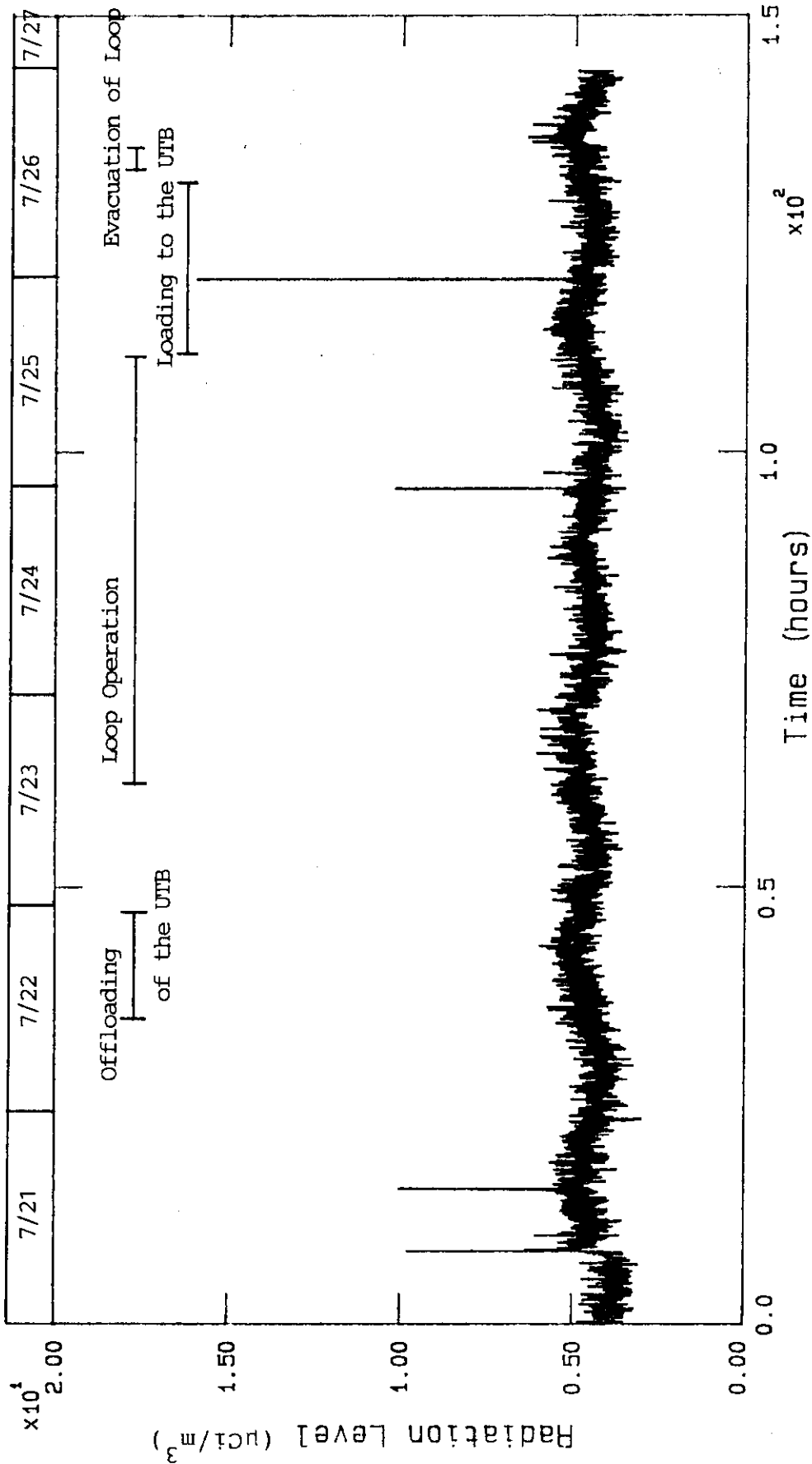

A VEN-R-STK : Radiation Level at the Stack
 BEGIN: 07/21/88 00:01:48
 END: 07/26/88 23:56:11
 2 minutes between samples

Fig. 3.20 Tritium radiation level at the stack of TSTA.

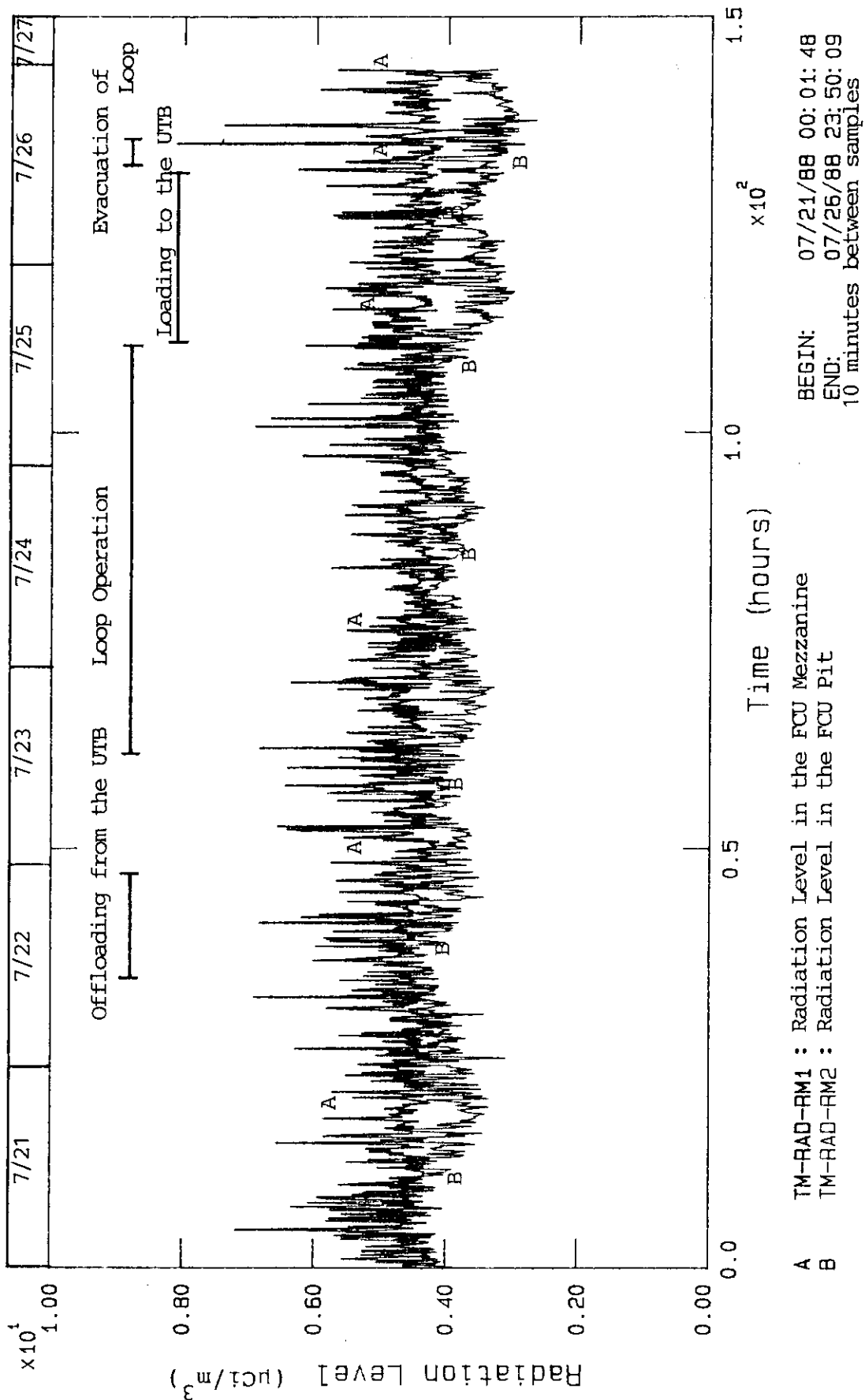
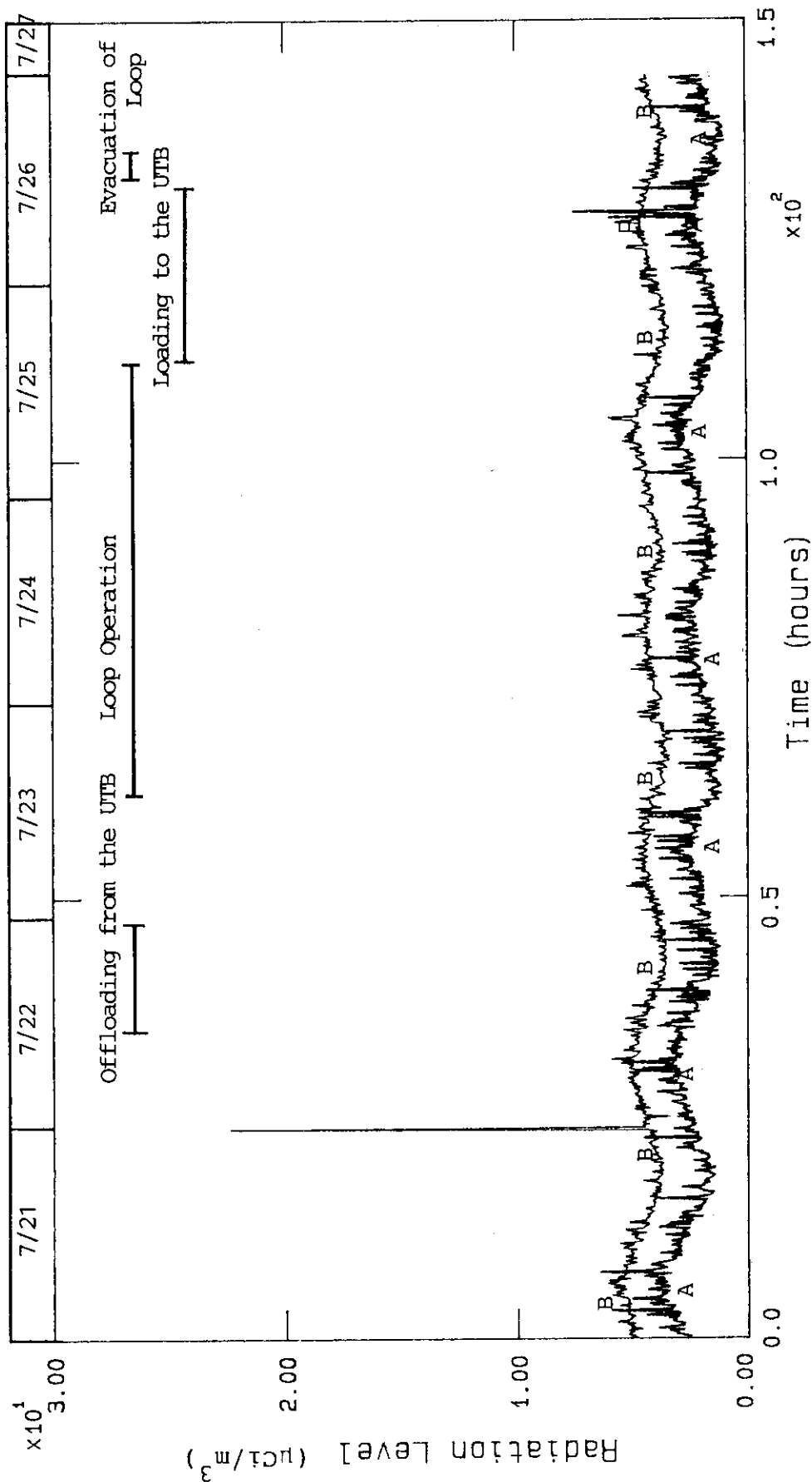

Fig. 3.22(a) Tritium radiation level at the FCU mezzanine and the FCU pit.



A TM-RAD-RM3 : Radiation Level in the ISS Mezzanine
 B TM-RAD-RM4 : Radiation Level in the VAC North
 BEGIN: 07/21/88 00: 01: 48
 END: 07/26/88 23: 50: 09
 10 minutes between samples

Fig. 3.22(b) Tritium radiation level at the ISS mezzanine and north of VAC.

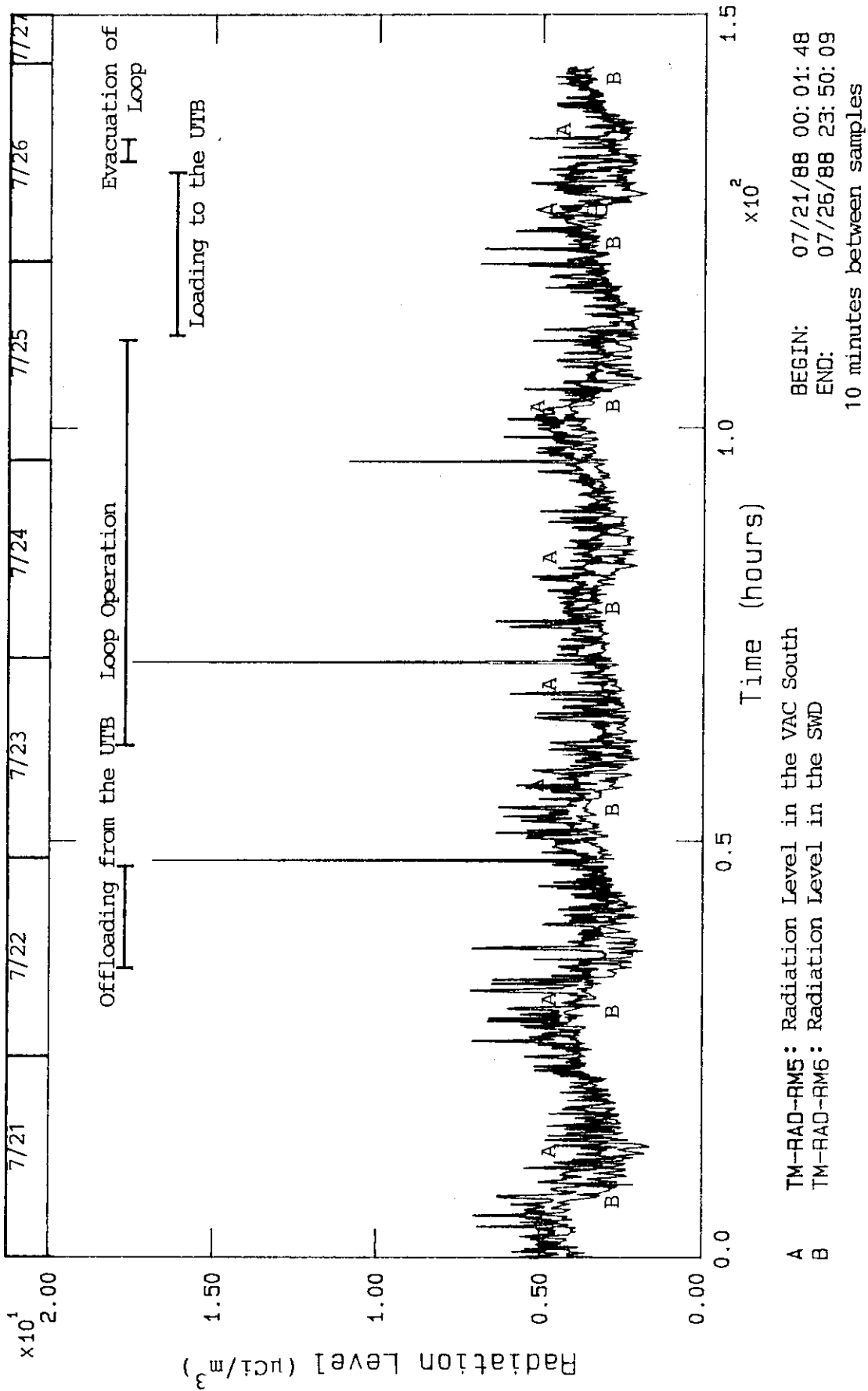

Fig. 3.22(c) Tritium radiation level at south of VAC and SWD.

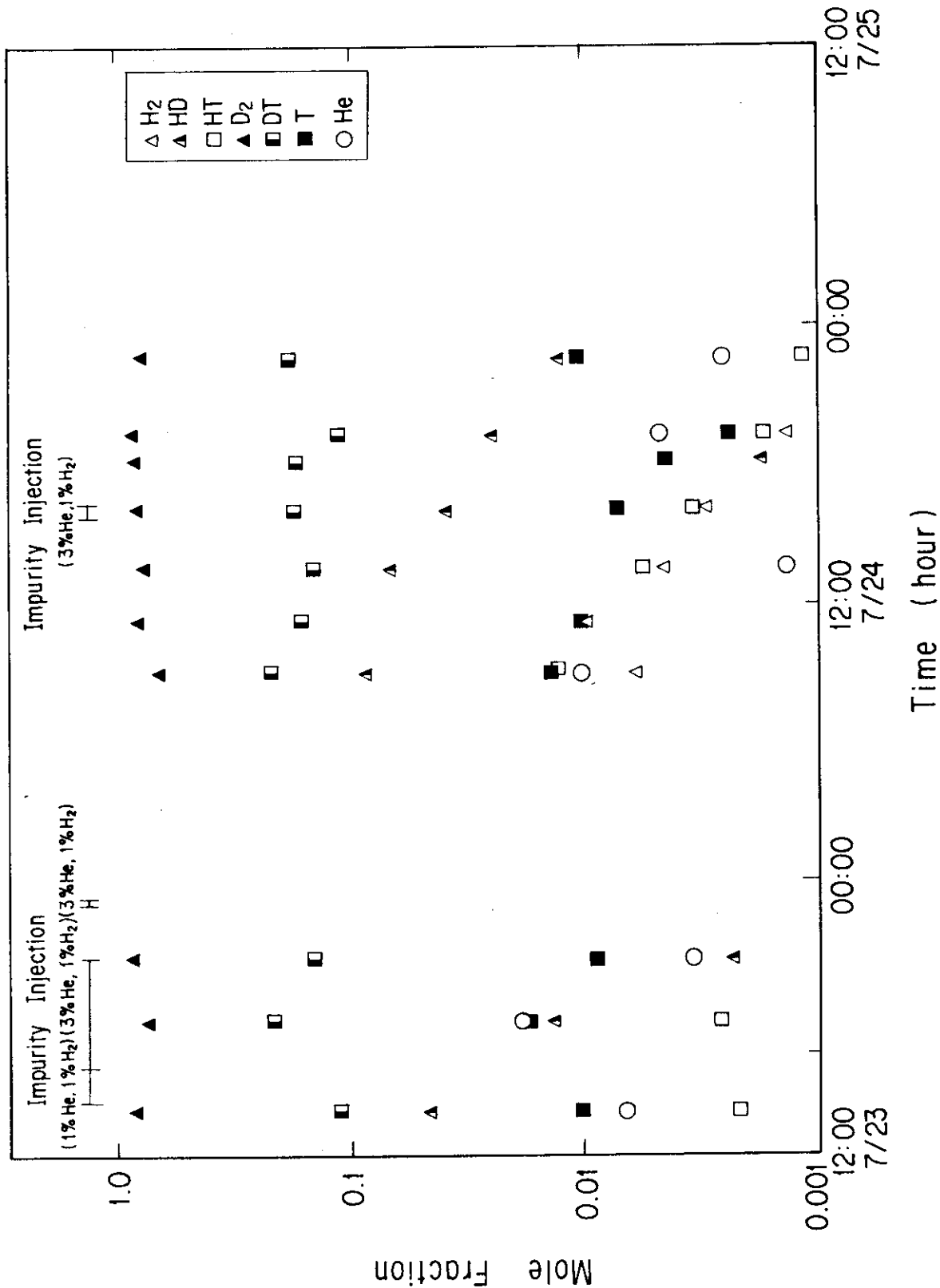

Fig. 3.23 Observed mole fraction of He and hydrogen isotopes in the feed stream of the column H.

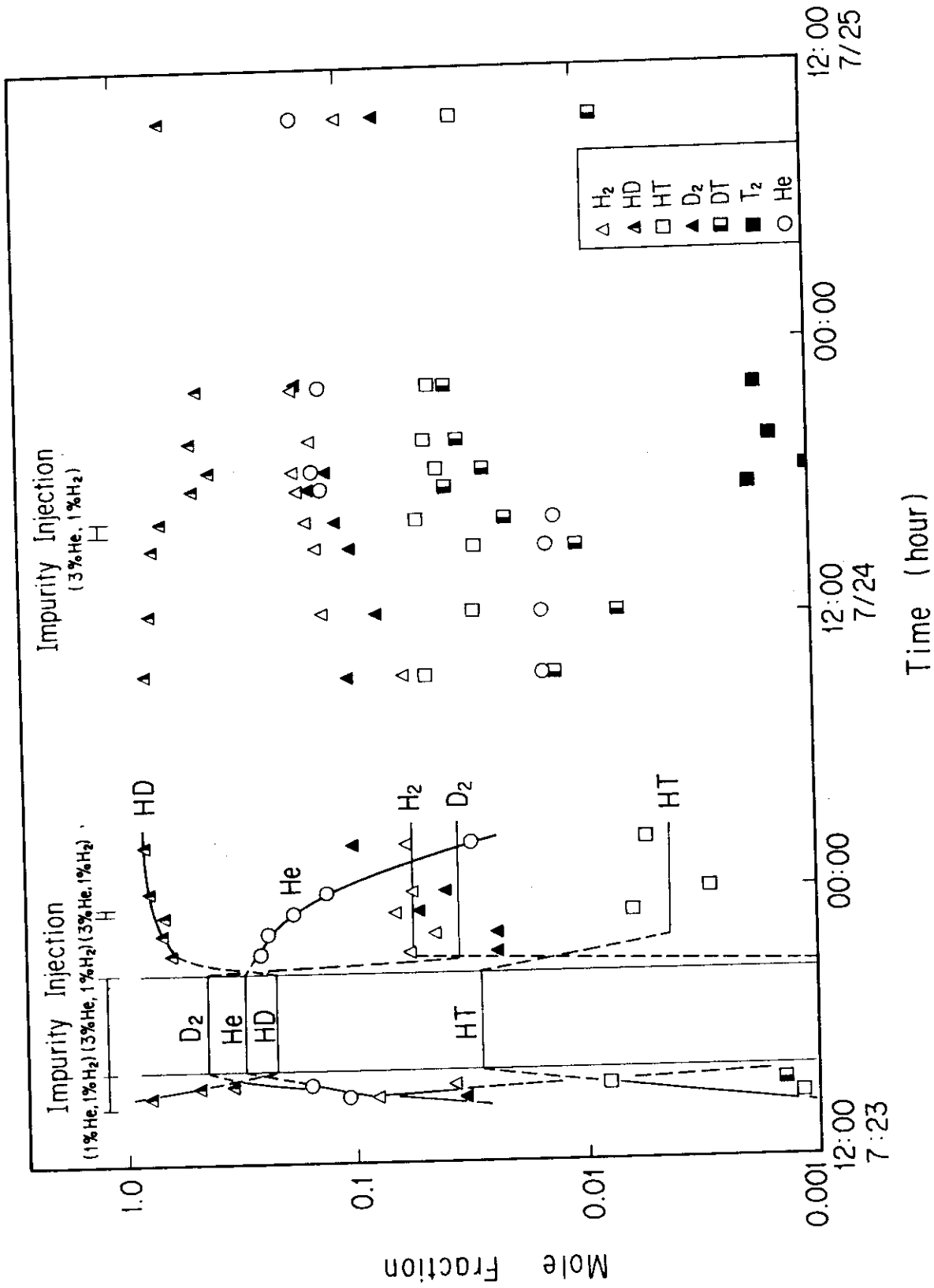

Fig. 3.24 Observed and calculated mole fractions of He and hydrogen isotopes in the top stream of the column H.