

JAERI-M
94-011

INDC(JPN)-168/L

ELASTIC AND INELASTIC SCATTERING OF
PROTONS FROM OXYGEN-16

February 1994

Norihiko KOORI,* Yukinobu WATANABE,**Hiroki HANE**
Hironari KASHIMOTO,**Akira AOTO,**Hidenobu IJIRI**
Kenji SAGARA,**Hiroyuki NAKAMURA,**Kazuhide MAEDA**
Takao NAKASHIMA**

日本原子力研究所
Japan Atomic Energy Research Institute

JAERI-Mレポートは、日本原子力研究所が不定期に公刊している研究報告書です。
入手の問合わせは、日本原子力研究所技術情報部情報資料課（〒319-11茨城県那珂郡東海村）
あて、お申しこしてください。なお、このほかに財団法人原子力弘済会資料センター（〒319-11茨城
県那珂郡東海村日本原子力研究所内）で複写による実費頒布をおこなっております。

JAERI-M reports are issued irregularly.
Inquiries about availability of the reports should be addressed to Information Division, Department
of Technical Information, Japan Atomic Energy Research Institute, Tokai-mura, Naka-gun,
Ibaraki-ken 319-11, Japan.

© Japan Atomic Energy Research Institute, 1994

編集兼発行 日本原子力研究所
印刷 日立高速印刷株式会社

Elastic and Inelastic Scattering
of Protons from Oxygen-16

Norihiko KOORI^{*}, Yukinobu WATANABE^{**}, Hiroki HANE^{**}
Hironari KASHIMOTO^{**}, Akira AOTO^{**}, Hidenobu IJIRI^{**}
Kenji SAGARA^{**}, Hiroyuki NAKAMURA^{**}
Kazuhide MAEDA^{**} and Takao NAKASHIMA^{**}

Department of Reactor Engineering
Tokai Research Establishment
Japan Atomic Energy Research Institute
Tokai-mura, Naka-gun, Ibaraki-ken

(Received January 17, 1994)

Double differential cross sections of the $^{16}\text{O}(p, p'x)$ reaction and differential cross sections and analyzing powers of polarized proton elastic and inelastic scattering were measured at 14 and 16 MeV. The optical potential parameter set, which was derived for ^{16}O from the spherical optical model analysis, reproduces the elastic scattering data fairly well. Large differences are found in the potential depths of the imaginary and spin-orbit terms between 14 and 16 MeV. This may be due to strong resonance structure in the compound nucleus of ^{17}F .

Keywords : $^{16}\text{O}(p, p')$ Reaction, Polarized Proton Experiment, Elastic Scattering, Inelastic Scattering, Double Differential Cross Section

This work was performed under the contract between Japan Atomic Energy Research Institute and The University of Tokushima in 1991 fiscal year.

* The University of Tokushima

** Kyushu University

酸素-16による陽子の弾性、非弾性散乱

日本原子力研究所東海研究所原子炉工学部

桑折 範彦*・渡辺 幸信**・羽根 博樹**・樫本 寛徳**
青砥 晃**・井尻 秀信**・相良 建至**・中村 裕之**
前田 和秀**・中島 孝夫**

(1994年1月17日受理)

14および16MeV偏極陽子による ^{16}O (p, p'x) 反応の二重微分断面積、弾性散乱および非弾性散乱の微分断面積と偏極分解能を測定した。球形光学模型によって弾性散乱のデータを解析した結果、かなり良く再現された。しかし、虚部ポテンシャルとスピン軌道ポテンシャルの深さは14MeVと16MeVで大きく変化しており、複合核 ^{17}F の強い共鳴構造が影響していると考えられる。

本報告書は、日本原子力研究所が平成3年度に徳島大学に委託して行った研究の成果である。

東海研究所：〒319-11 茨城県那珂郡東海村白方字白根2-4

* 徳島大学

** 九州大学

Contents

1. Introduction	1
2. Experimental Procedure	1
3. Experimental Results	2
4. Theoretical Analysis and Discussion	3
5. Summary	5
References	6
Appendices	22

目 次

1. 緒言	1
2. 実験方法	1
3. 実験結果	2
4. 理論解析と議論	3
5. 結語	5
文献	6
付録	22

1. Introduction

We have been studying the interaction of nucleon with light nuclei (1p-shell nuclei) in the incident energy range of 10-20 MeV in order to establish reliable theories and models for evaluation of neutron nuclear data for applications[1-5].

Detailed studies of the neutron scattering from light nuclei are important for several applications such as estimation of radiation damage, neutron shielding design in fusion energy development, and evaluation of kerma factors needed for high energy neutron radiotherapy. Double differential cross sections (DDXs) for the reaction are required for more accurate calculations of neutron transport and kerma factors. Parameters of the optical potentials for light nuclei are also indispensable as fundamental data to understand the reaction mechanism.

Until now, some of the present authors have studied neutron-induced reactions for lithium isotopes, carbon, and several medium heavy nuclei through experimental investigations of proton-induced reactions[1-5], because they are similar to neutron-induced reactions in their reaction mechanism. In the present work, this approach was also applied to investigation of the nucleon- ^{16}O interaction. DDXs and analyzing powers were measured for protons emitted from the bombardment of ^{16}O with 14 and 16 MeV polarized protons. From the measured data, differential cross sections and analyzing powers of elastic and discrete inelastic proton scattering from ^{16}O were extracted for the analysis with the spherical optical model (SOM) and the coupled-channels (CC) method, and they were compared with available neutron scattering data.

2. Experimental procedure

The experiment was performed using 14 and 16 MeV polarized proton beams from the tandem Van de Graaff accelerator at Kyushu University. Commercial oxygen gas was used as target gas: its purity was 99.5%, and isotopic content of ^{16}O was 99.795%. The

1. Introduction

We have been studying the interaction of nucleon with light nuclei (1p-shell nuclei) in the incident energy range of 10-20 MeV in order to establish reliable theories and models for evaluation of neutron nuclear data for applications[1-5].

Detailed studies of the neutron scattering from light nuclei are important for several applications such as estimation of radiation damage, neutron shielding design in fusion energy development, and evaluation of kerma factors needed for high energy neutron radiotherapy. Double differential cross sections (DDXs) for the reaction are required for more accurate calculations of neutron transport and kerma factors. Parameters of the optical potentials for light nuclei are also indispensable as fundamental data to understand the reaction mechanism.

Until now, some of the present authors have studied neutron-induced reactions for lithium isotopes, carbon, and several medium heavy nuclei through experimental investigations of proton-induced reactions[1-5], because they are similar to neutron-induced reactions in their reaction mechanism. In the present work, this approach was also applied to investigation of the nucleon- ^{16}O interaction. DDXs and analyzing powers were measured for protons emitted from the bombardment of ^{16}O with 14 and 16 MeV polarized protons. From the measured data, differential cross sections and analyzing powers of elastic and discrete inelastic proton scattering from ^{16}O were extracted for the analysis with the spherical optical model (SOM) and the coupled-channels (CC) method, and they were compared with available neutron scattering data.

2. Experimental procedure

The experiment was performed using 14 and 16 MeV polarized proton beams from the tandem Van de Graaff accelerator at Kyushu University. Commercial oxygen gas was used as target gas: its purity was 99.5%, and isotopic content of ^{16}O was 99.795%. The

gas was filled at a pressure of 0.4 atm (at room temperature) in a gas cell of a stainless steel cylinder of 38 mm in diameter and of 34 mm in height. The cell windows were made of 2.2 μm havar foil for the beam entrance and exit, and of 6 μm mylar foil for scattered protons. Energy losses of 14 MeV protons were 31.9 keV in the target gas and 40.3 keV in the entrance havar foil; those of 16 MeV protons were 28.9 keV in the target gas and 36.6 keV in the havar foil. The incident beam energy was chosen so as to be 14.0 or 16.0 MeV at the target center.

The detection system was almost the same as those reported elsewhere [5]. A ΔE -E counter telescope consisting of three silicon surface barrier detectors (E1: 20 μm , E2: 75 μm , E3: 2000 μm) was employed for detection of protons. As shown in Fig.1, the counter telescope was set up with double-slit geometry: the first slit with opening of 2 mm was located 23.8 mm from the center of the gas target cell and the second slit was located just in front of the ΔE detector and the distance from the first slit was 178.2 mm. Multiple scattering of protons in the target oxygen gas in the cell was estimated to be 1.17° for 2 MeV protons and 0.15° for 16 MeV protons. If the spreads are compared with the geometrical angular resolution of the detection system, the effect may be negligible in the interested energy region. The energy resolution of the counter telescope was 135 keV in fwhm. Energy losses in the mylar foil of the cell were estimated to be 81 keV for 2 MeV protons and 17 keV for 16 MeV protons, which were smaller than the energy resolution of the telescope. The measurement of DDXs was performed at 13 angles between 30° and 150°.

Beam polarization was monitored using a polarimeter consisting of ^4He gas target and two ΔE -E silicon detectors [6] at the down stream of a scattering chamber. The beam polarization obtained was 70-80% for the spin-up beam, and 45-55% for the spin-down beam.

3. Experimental results

The measured DDXs of the $^{16}\text{O}(p,p'x)$ reaction are shown in Fig.2 for 14 MeV and in Fig.3 for 16 MeV. Contribution from contaminated elements in the target gas and the

gas was filled at a pressure of 0.4 atm (at room temperature) in a gas cell of a stainless steel cylinder of 38 mm in diameter and of 34 mm in height. The cell windows were made of 2.2 μm havar foil for the beam entrance and exit, and of 6 μm mylar foil for scattered protons. Energy losses of 14 MeV protons were 31.9 keV in the target gas and 40.3 keV in the entrance havar foil; those of 16 MeV protons were 28.9 keV in the target gas and 36.6 keV in the havar foil. The incident beam energy was chosen so as to be 14.0 or 16.0 MeV at the target center.

The detection system was almost the same as those reported elsewhere [5]. A ΔE -E counter telescope consisting of three silicon surface barrier detectors (E1: 20 μm , E2: 75 μm , E3: 2000 μm) was employed for detection of protons. As shown in Fig.1, the counter telescope was set up with double-slit geometry: the first slit with opening of 2 mm was located 23.8 mm from the center of the gas target cell and the second slit was located just in front of the ΔE detector and the distance from the first slit was 178.2 mm. Multiple scattering of protons in the target oxygen gas in the cell was estimated to be 1.17° for 2 MeV protons and 0.15° for 16 MeV protons. If the spreads are compared with the geometrical angular resolution of the detection system, the effect may be negligible in the interested energy region. The energy resolution of the counter telescope was 135 keV in fwhm. Energy losses in the mylar foil of the cell were estimated to be 81 keV for 2 MeV protons and 17 keV for 16 MeV protons, which were smaller than the energy resolution of the telescope. The measurement of DDXs was performed at 13 angles between 30° and 150°.

Beam polarization was monitored using a polarimeter consisting of ^4He gas target and two ΔE -E silicon detectors [6] at the down stream of a scattering chamber. The beam polarization obtained was 70-80% for the spin-up beam, and 45-55% for the spin-down beam.

3. Experimental results

The measured DDXs of the $^{16}\text{O}(p,p'x)$ reaction are shown in Fig.2 for 14 MeV and in Fig.3 for 16 MeV. Contribution from contaminated elements in the target gas and the

edge scattering at the slit in front of the counter telescope are not corrected in these spectra, and scattering by the havar foil of the beam entrance and exit may contribute to low energy part of the spectra for forward angles of 30° and 40° . Numerical data are given in Appendix-1 and -2.

Differential cross sections and analyzing powers of the elastic scattering and inelastic scattering to the discrete levels (0^+ : 6.049 MeV, 3^- : 6.130 MeV, 2^+ : 6.919 MeV, 1^- : 7.1169 MeV) are presented in Fig.4 for 14 MeV and in Fig.5 for 16 MeV. Since two discrete levels of 0^+ and 3^- could not be separated, the angular distribution and analyzing powers are given as their sum. The experimental errors were estimated on the basis of their statistical ones and the systematic ones due to the normalization (2 %) and the geometrical factor of the double-slit measurement with the gas target (6 %). As found in Figs.4 and 5, the angular distributions and analyzing powers vary evidently as the incident energy is increased from 14 to 16 MeV. This tendency is different from the case of the $^{12}\text{C}(p,p')$ scattering, where no appreciable difference was observed in the angular distributions and analyzing powers for 14 and 16 MeV[3]. Numerical data are given in Appendix-3 and -4.

The measured proton scattering data are compared with neutron scattering data[7] for 14 MeV in Fig.6, where closed circles present the proton scattering data and open circles the neutron scattering data. As shown in Fig.6, differences between the proton and neutron data are evident around the minima in the angular distribution of the elastic scattering. In the inelastic scattering for $Q=-6.09$ MeV the proton data show a flatter angular distribution than the neutron data, while the angular distributions are similar in the inelastic scattering for $Q=-7.018$ MeV.

4. Theoretical analysis and discussion

The measured elastic scattering data were analyzed by the spherical optical model (SOM) using the potential of a standard form with a Woods-Saxon real volume, surface derivative imaginary, and spin-orbit terms. SOM fits were performed for the elastic

edge scattering at the slit in front of the counter telescope are not corrected in these spectra, and scattering by the havar foil of the beam entrance and exit may contribute to low energy part of the spectra for forward angles of 30° and 40° . Numerical data are given in Appendix-1 and -2.

Differential cross sections and analyzing powers of the elastic scattering and inelastic scattering to the discrete levels (0^+ : 6.049 MeV, 3^- : 6.130 MeV, 2^+ : 6.919 MeV, 1^- : 7.1169 MeV) are presented in Fig.4 for 14 MeV and in Fig.5 for 16 MeV. Since two discrete levels of 0^+ and 3^- could not be separated, the angular distribution and analyzing powers are given as their sum. The experimental errors were estimated on the basis of their statistical ones and the systematic ones due to the normalization (2 %) and the geometrical factor of the double-slit measurement with the gas target (6 %). As found in Figs.4 and 5, the angular distributions and analyzing powers vary evidently as the incident energy is increased from 14 to 16 MeV. This tendency is different from the case of the $^{12}\text{C}(p,p')$ scattering, where no appreciable difference was observed in the angular distributions and analyzing powers for 14 and 16 MeV[3]. Numerical data are given in Appendix-3 and -4.

The measured proton scattering data are compared with neutron scattering data[7] for 14 MeV in Fig.6, where closed circles present the proton scattering data and open circles the neutron scattering data. As shown in Fig.6, differences between the proton and neutron data are evident around the minima in the angular distribution of the elastic scattering. In the inelastic scattering for $Q=-6.09$ MeV the proton data show a flatter angular distribution than the neutron data, while the angular distributions are similar in the inelastic scattering for $Q=-7.018$ MeV.

4. Theoretical analysis and discussion

The measured elastic scattering data were analyzed by the spherical optical model (SOM) using the potential of a standard form with a Woods-Saxon real volume, surface derivative imaginary, and spin-orbit terms. SOM fits were performed for the elastic

differential cross sections and analyzing powers using the code ECIS79[8].

Figure 7 shows comparisons of the measured differential cross sections and analyzing powers with the calculated results on the basis of the previously proposed parameters of the optical model potential (OMP)[9-11]; the parameters from the neutron scattering were used after the fixed Coulomb correction $\Delta V = 0.4 Z/A^{1/3}$ was made in the real volume potential. Although the parameter set of Duke[9] can reproduce fairly well the differential cross sections for both measured energies, it does not provide good agreement in the analyzing powers. The parameter sets of Dave and Gould[10] and Islam et al.[11] give better fits for the analyzing powers, but worse fits to the differential cross sections over the whole angular range in comparison with the parameter set of Duke.

The OMP parameters were searched in order to obtain better fits to both the differential cross sections and analyzing powers. The OMP parameter set derived by Dave and Gould was used for the search as an initial one (Set 0) with the fixed Coulomb correction in the real volume potential. The results of SOM fits are shown by solid lines for 14 and 16 MeV in Fig.8, and the obtained OMP parameters are listed in Table I. A parameter set denoted by Set 1 is the result of all parameter research including potential depths and geometrical parameters. There is a large difference between Set 0 and Set 1 in the imaginary part of the depth W_D and the spin-orbit term W_{SO} . Although the fit seems to be fairly well over the whole angular range, the calculation provides smaller cross sections than the measured ones in the angular range of $60^\circ - 100^\circ$. The analyzing powers for 14 MeV are well reproduced by the calculation, but agreement with those for 16 MeV is not so good, especially around 50° and 120° .

As shown in Table I, the geometrical parameters of Set 1 are slightly energy-dependent. In order to study the energy dependence of the potential depth, a parameter search was furthermore performed with fixed geometrical parameters that were obtained from averaging of the parameters of Set 1 for 14 and 16 MeV. The result of the search is given as Set 2. Agreement in the analyzing powers for 14 MeV becomes worse around 50° ; in its stead the fit around 50° and 120° is much improved for 16 MeV (shown by dashed lines in Fig.8).

Finally, the OMP parameters were searched with the potential incorporating an imaginary spin-orbit term W_{SO} . The resulted parameters are given as Set 3 in Table I. The present OMP parameters for ^{16}O are characterized by small diffusenesses of the surface imaginary and spin-orbit terms in comparison with those for ^{12}C [3]. Fits to the experimental data are not so much different from those with Set 2 in this case. Fairly good overall fits are indicated for both 14 and 16 MeV, as shown by dotted lines (Set 3) in Fig.8.

As shown in Fig.8, a remarkable difference between 14 and 16 MeV is observed in the measured analyzing powers around 90° . This may suggest strong resonance structure in the compound nucleus ^{17}F ; a broad $f_{7/2}$ single particle level in ^{17}F around 17.5 MeV[12] and an appreciably sharp resonance at 14.7 MeV in the elastic scattering excitation functions have been reported[13]. The experimental values are, however, reproduced fairly well by the SOM calculation, as shown above. Largely different potential depths of the imaginary and spin-orbit terms (W_D , V_{SO} and W_{SO}) between 14 and 16 MeV are needed to obtain good fits, as shown Table I. This means the effect from the resonance of the compound nucleus and from the coupling of the other channels should be taken into account by using the coupled-channels (CC) method. The difference in the energy dependence is rather large in comparison with the case of medium-heavy nuclei[14] and ^{12}C [15]. For detailed discussion, it will be needed to study in wider energy range and more systematic measurements.

5. Summary

Differential cross sections and analyzing powers of proton elastic and inelastic scattering from ^{16}O were measured at 14 and 16 MeV. Optical potential parameter sets for ^{16}O were derived from the SOM analysis. The experimental data are reproduced fairly well by the finally obtained parameter set. A large difference was found in the potential depths of the imaginary and spin-orbit terms (W_D , V_{SO} and W_{SO}) between 14 and 16 MeV. It would be necessary to investigate the effect of resonance structure of the compound nucleus ^{17}F .

Finally, the OMP parameters were searched with the potential incorporating an imaginary spin-orbit term W_{SO} . The resulted parameters are given as Set 3 in Table I. The present OMP parameters for ^{16}O are characterized by small diffusenesses of the surface imaginary and spin-orbit terms in comparison with those for ^{12}C [3]. Fits to the experimental data are not so much different from those with Set 2 in this case. Fairly good overall fits are indicated for both 14 and 16 MeV, as shown by dotted lines (Set 3) in Fig.8.

As shown in Fig.8, a remarkable difference between 14 and 16 MeV is observed in the measured analyzing powers around 90° . This may suggest strong resonance structure in the compound nucleus ^{17}F ; a broad $f_{7/2}$ single particle level in ^{17}F around 17.5 MeV[12] and an appreciably sharp resonance at 14.7 MeV in the elastic scattering excitation functions have been reported[13]. The experimental values are, however, reproduced fairly well by the SOM calculation, as shown above. Largely different potential depths of the imaginary and spin-orbit terms (W_D , V_{SO} and W_{SO}) between 14 and 16 MeV are needed to obtain good fits, as shown Table I. This means the effect from the resonance of the compound nucleus and from the coupling of the other channels should be taken into account by using the coupled-channels (CC) method. The difference in the energy dependence is rather large in comparison with the case of medium-heavy nuclei[14] and ^{12}C [15]. For detailed discussion, it will be needed to study in wider energy range and more systematic measurements.

5. Summary

Differential cross sections and analyzing powers of proton elastic and inelastic scattering from ^{16}O were measured at 14 and 16 MeV. Optical potential parameter sets for ^{16}O were derived from the SOM analysis. The experimental data are reproduced fairly well by the finally obtained parameter set. A large difference was found in the potential depths of the imaginary and spin-orbit terms (W_D , V_{SO} and W_{SO}) between 14 and 16 MeV. It would be necessary to investigate the effect of resonance structure of the compound nucleus ^{17}F .

References

- [1] N. Koori et al.: JAERI-M 89-167 (1989).
- [2] N. Koori et al.: JAERI-M 91-009 (1991).
- [3] N. Koori et al.: JAERI-M 92-029 (1992).
- [4] Y. Watanabe et al.: Proc. Int. Conf. on Nuclear Data for Science and Technology, Julich, p.13 (1991).
- [5] N. Koori et al.: Proc. of 1991 Symp. on Nuclear Data, JAERI-M 92-027 (1992).
- [6] K. Sagara et al.: Nucl. Instr. & Meth. **A270**, 444 (1988).
- [7] M. Baba et al.: Fast Neutron Laboratory Report NETU-50, Tohoku Univ. (1988).
- [8] J. Raynal, The structure of nuclei, Int. course on nuclear theory, Trieste, 1971 (IAEA-SMR-8/8, Wien, 1972) p.75.
- [9] D.B. Duke: Phys Rev. **129**, 681 (1963).
- [10] J.H. Dave and C.R. Gould: Phys. Rev. **C28**, 2212 (1983).
- [11] M.S. Islam et al.: Nucl. Phys. **A464**, 395 (1987).
- [12] H.R. Hiddleston et al.: Nucl. Phys. **A242**, 323 (1975).
- [13] S. Kobayashi, J. Phys. Soc.Japan **15**, 1164 (1960).
- [14] F.D. Becchetti, Jr. and G.W. Greenlees: Phys. Rev. **182**, 1190 (1969).
- [15] E. Woye et al.: Nucl. Phys. **A394**, 139 (1983).

Table I The OMP parameters obtained in the present analysis for ^{16}O . Each parameter set as follows; Set 0: the initial value for the search, Set 1: results of the all parameter search, Set 2: results of the search with fixed geometrical parameters, Set 3: results of the same search as Set 2 except the inclusion of imaginary spin-orbit term. Potential depths in MeV and geometrical parameters in fm.

	Set 0		Set 1		Set 2		Set 3	
	14 MeV	16 MeV	14 MeV	16 MeV	14 MeV	16 MeV	14 MeV	16 MeV
V_R	48.78	48.67	53.70	49.46	48.82	54.62	48.78	54.33
r_R	1.255	1.255	1.201	1.276	1.238	1.238	1.238	1.238
a_R	0.536	0.536	0.479	0.621	0.550	0.550	0.550	0.550
W_D	12.20	13.31	6.724	15.83	7.409	13.17	7.480	13.89
r_I	1.352	1.352	1.346	1.426	1.386	1.386	1.386	1.386
a_I	0.205	0.205	0.212	0.152	0.182	0.182	0.182	0.182
V_{SO}	5.5	5.5	6.392	2.828	5.064	3.153	5.098	2.884
W_{SO}							-0.056	0.305
r_{SO}	1.15	1.15	0.935	1.237	1.086	1.086	1.086	1.086
a_{SO}	0.5	0.5	0.385	0.260	0.322	0.322	0.322	0.322
$(\chi^2/N)_\sigma$			3.35	8.26	9.93	21.45	9.90	20.33
$(\chi^2/N)_{Ay}$			6.23	52.61	28.57	44.38	28.52	34.74
$(J/A)_V$	543	541	505	623	532	595	532	592
$(J/A)_D$	101.8	111.1	57.5	108	57.5	102	58.0	107
$(J/A^{1/3})_{V_{SO}}$	159	159	150	87.9	138	86.1	139	78.7
$(J/A^{1/3})_{W_{SO}}$							-1.53	8.32

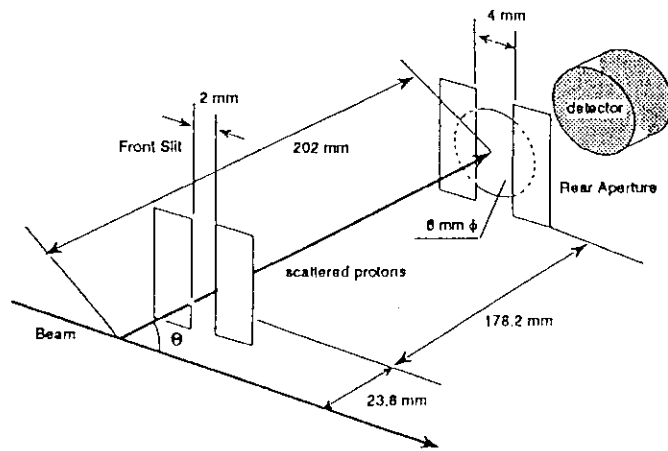
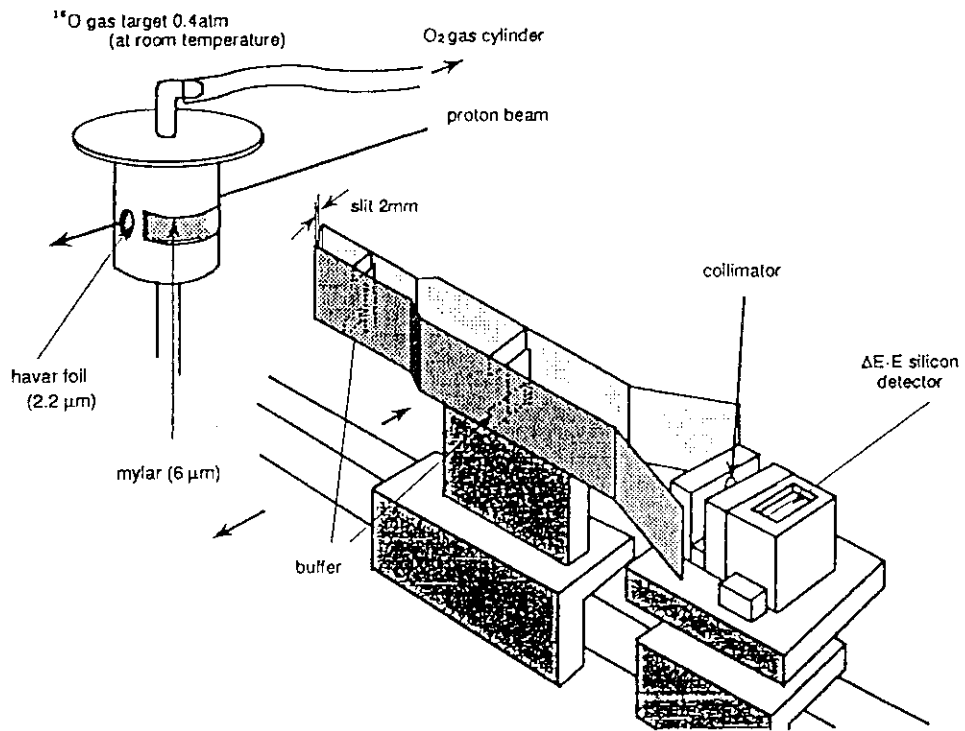

Fig.1 Layout and geometry of the detection system.

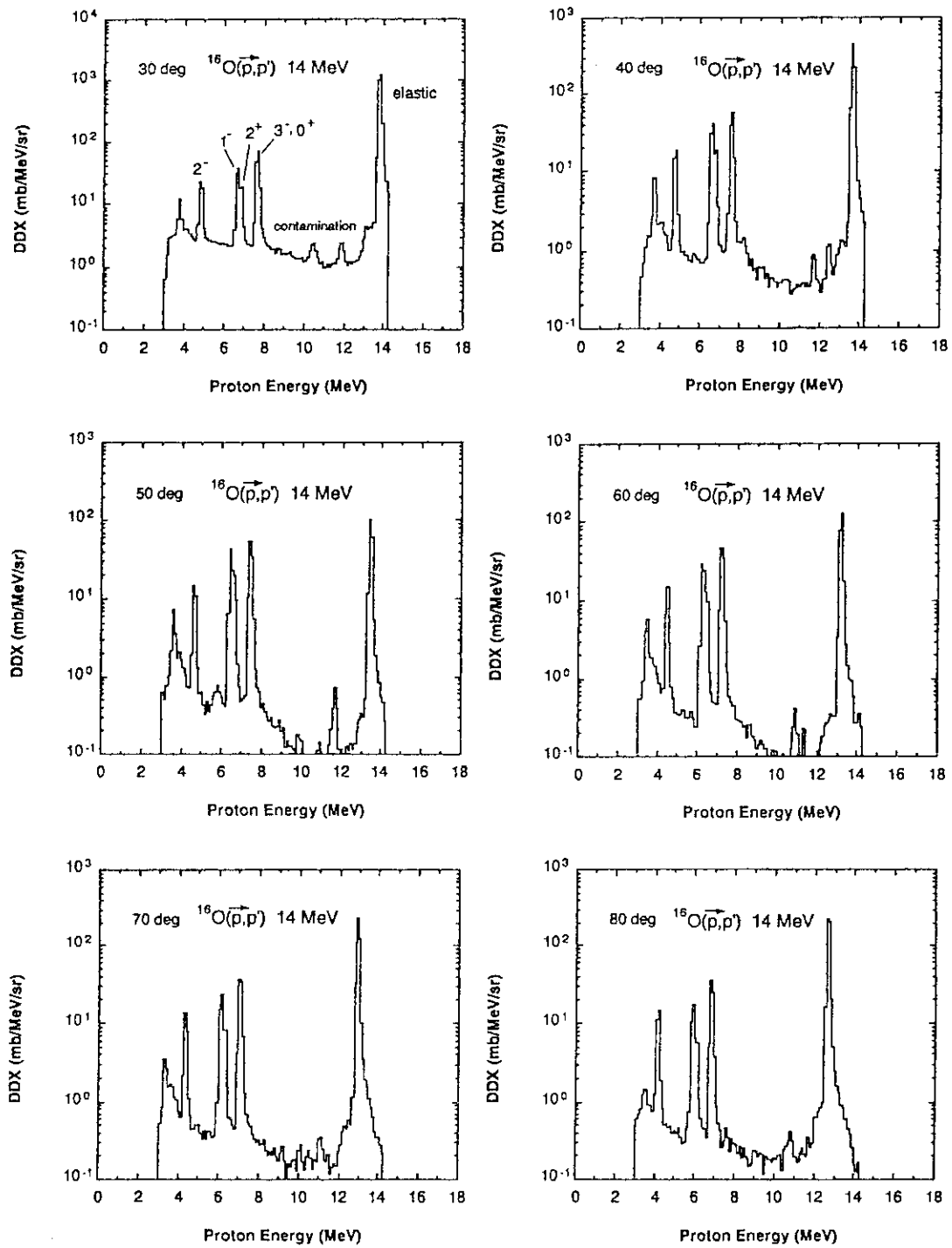

Fig.2 Double differential cross sections of the $^{16}\text{O}(p,p')$ reaction at 14 MeV.

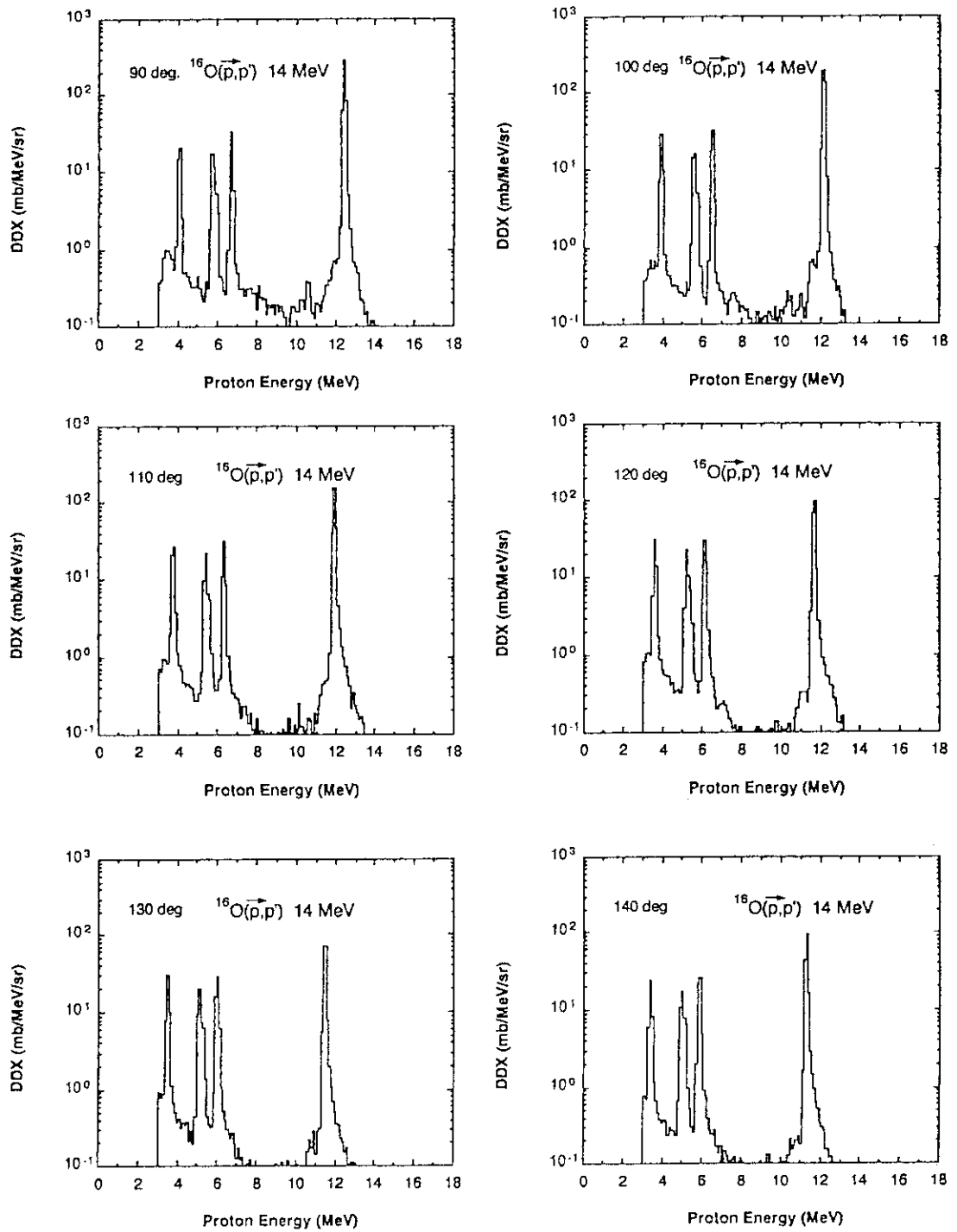

Fig.2 Continued.

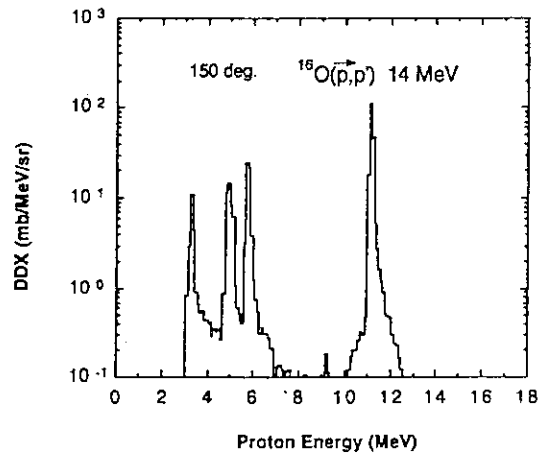

Fig.2 Continued.

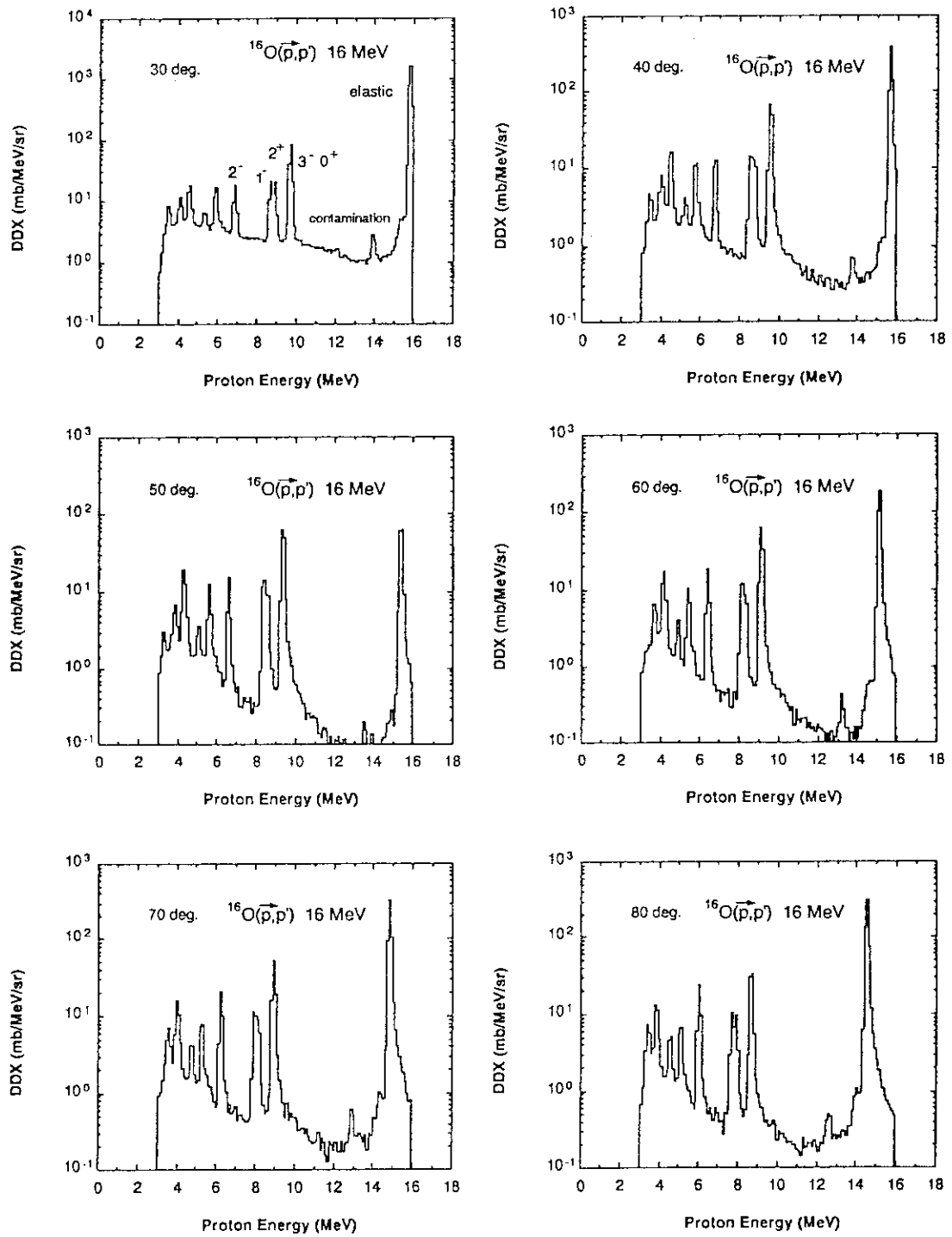

Fig.3 Double differential cross sections of the $^{16}\text{O}(p,p'x)$ reaction at 16 MeV.

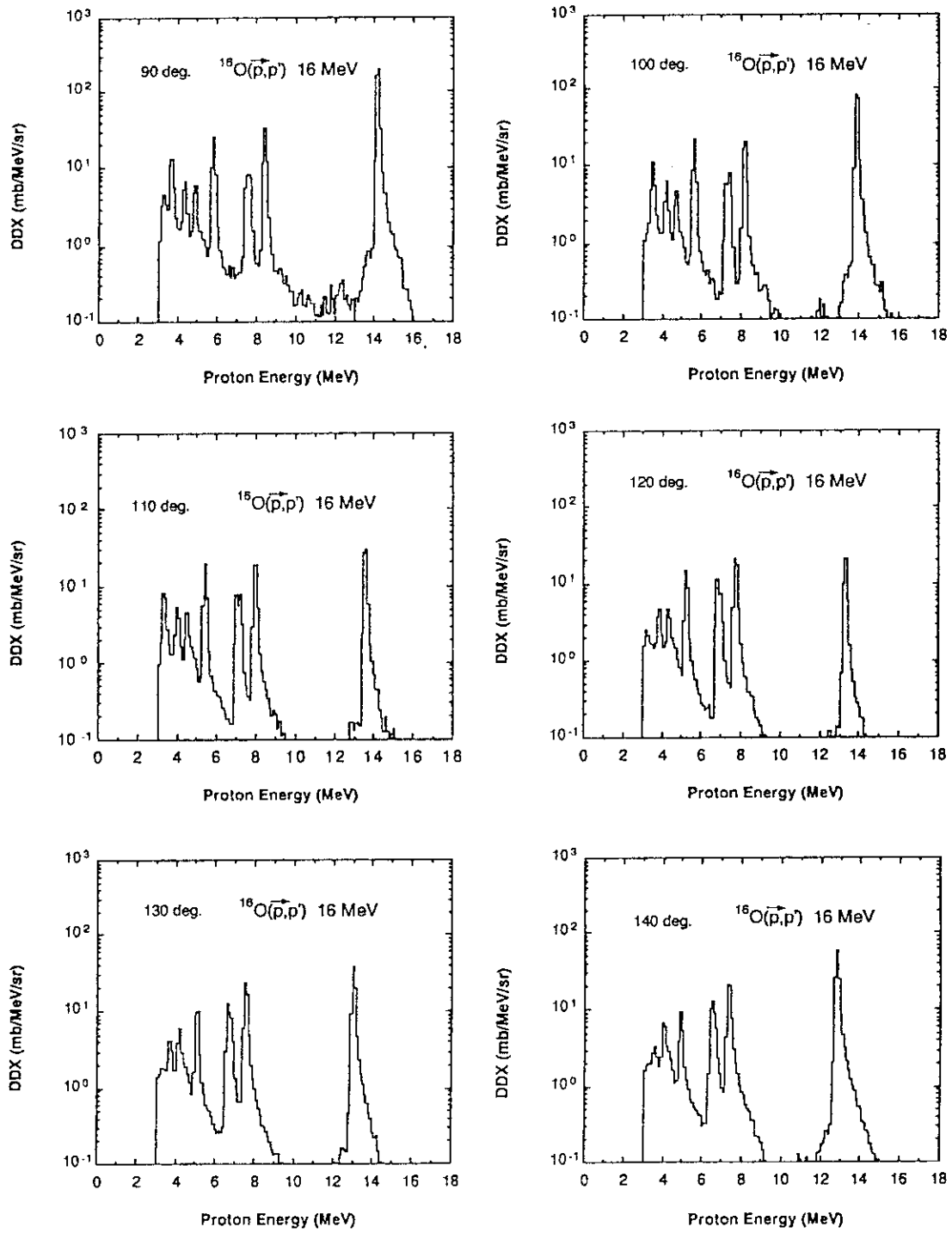

Fig.3 Continued.

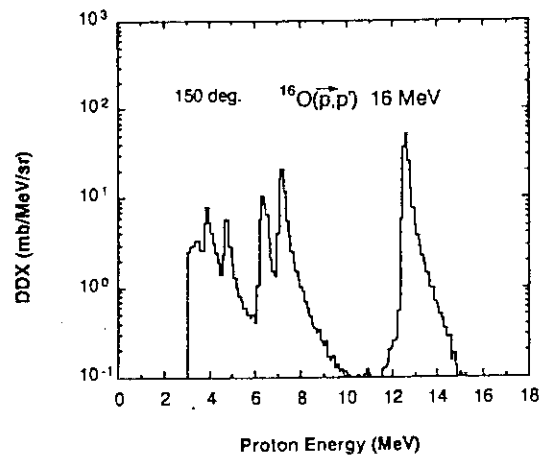

Fig.3 Continued.

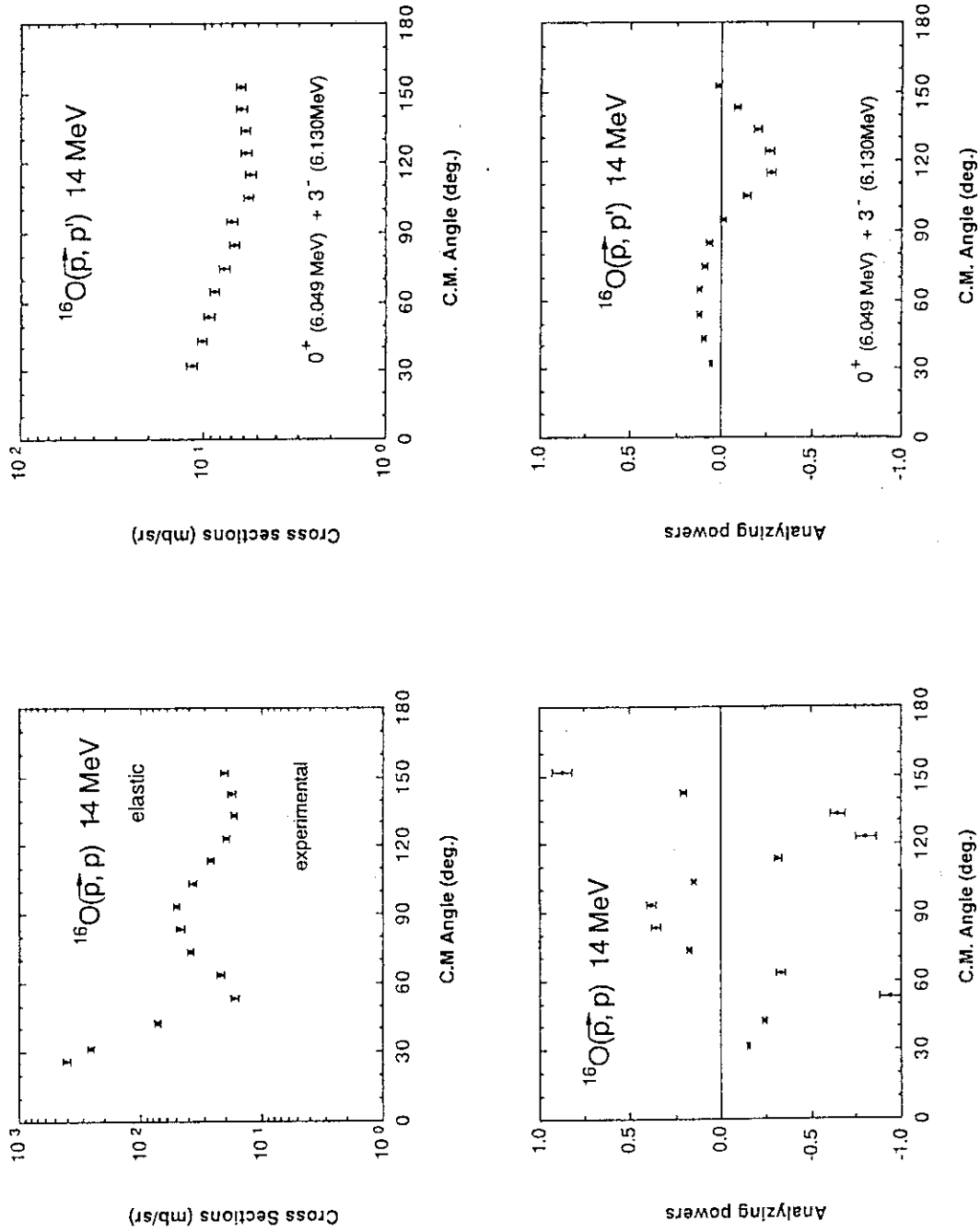

Fig.4 Differential cross sections and analyzing powers of the $^{16}\text{O}(p,p)$ elastic scattering and inelastic scattering to the 0^+ and 3^- states, the 2^+ state, and the 1^- state at 14 MeV.

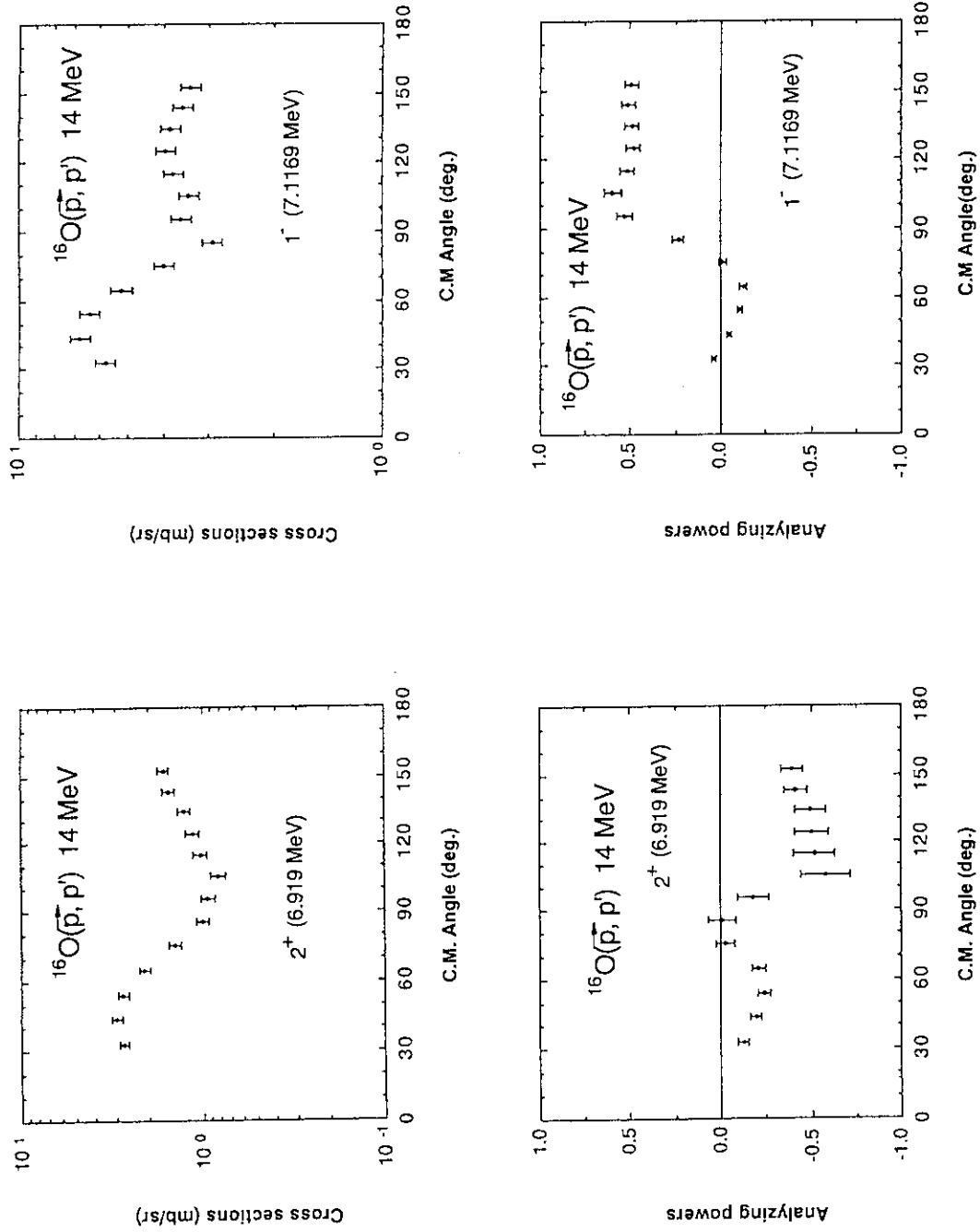

Fig.4 Continued.

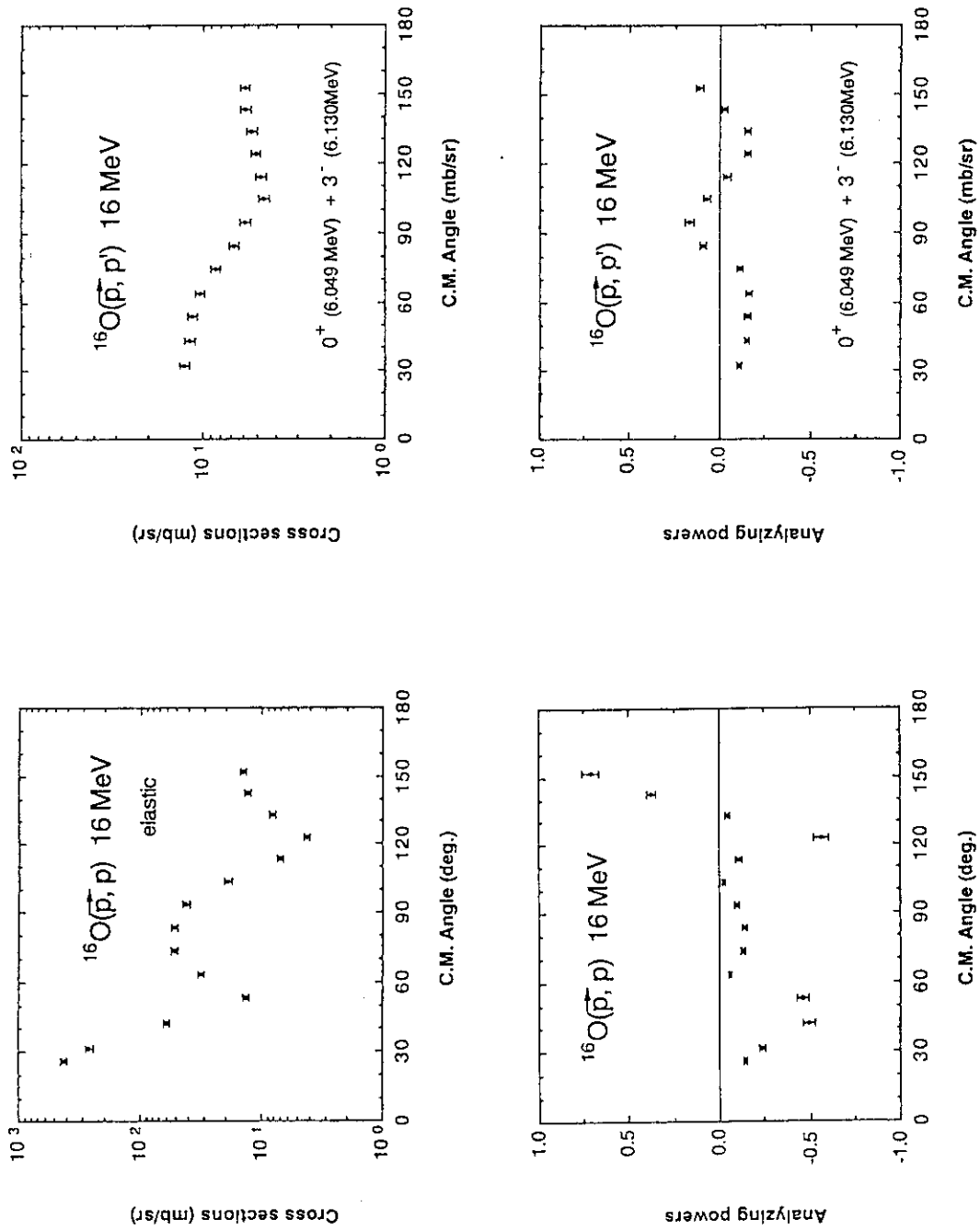

Fig.5 Differential cross sections and analyzing powers of the $^{16}\text{O}(p, p)$ elastic scattering and inelastic scattering to the 0^+ and 3^- states, the 2^+ state, and the 1^- state at 16 MeV.

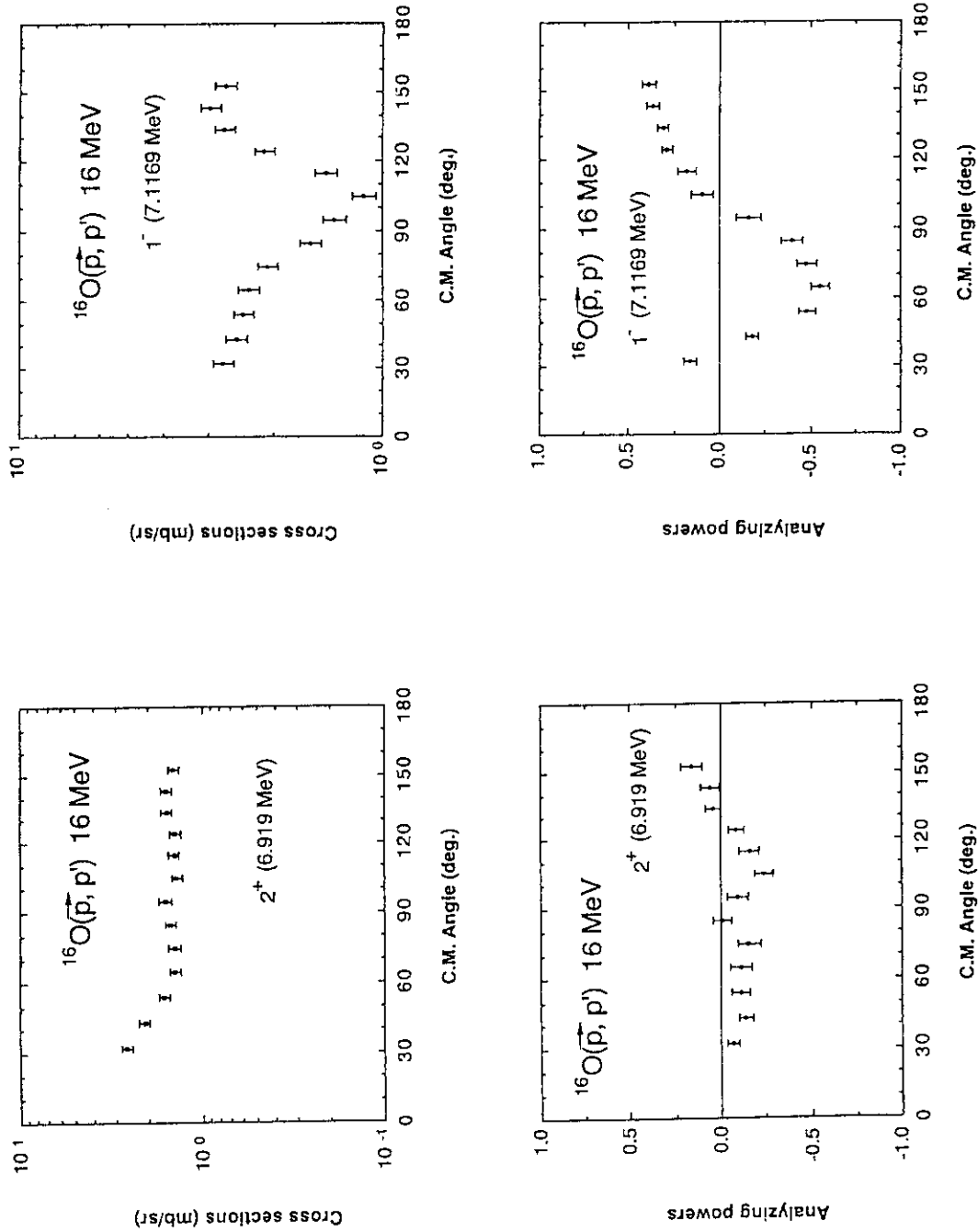

Fig.5 Continued.

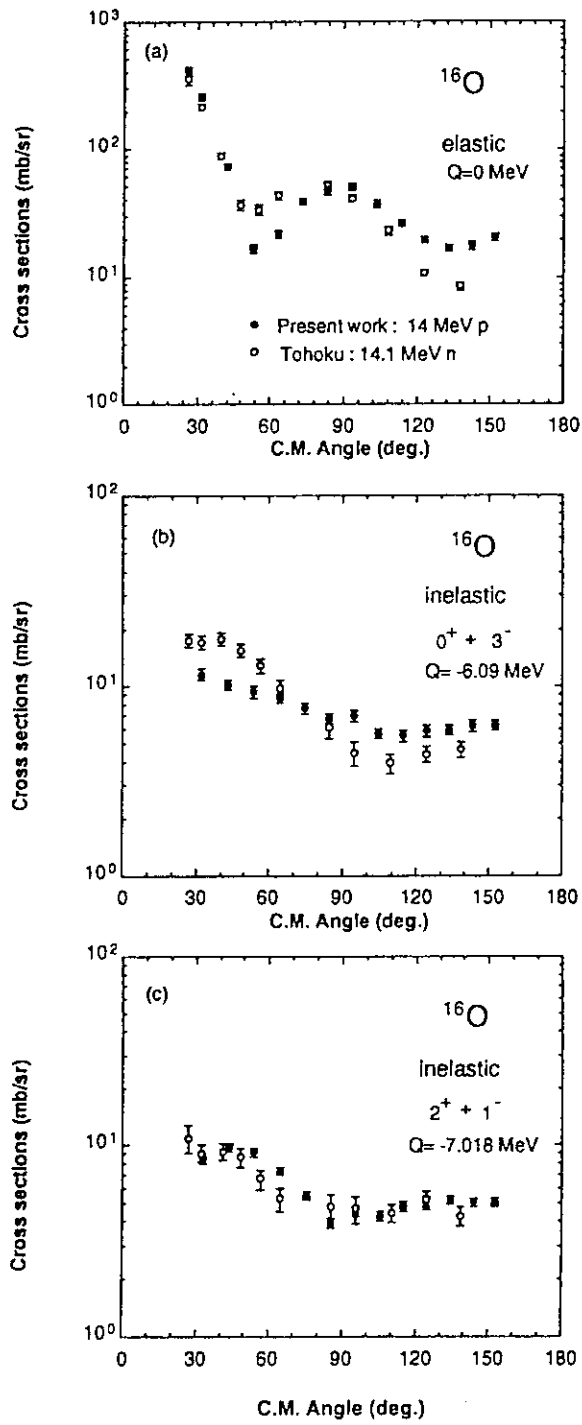

Fig.6 Comparison of the proton scattering data with the neutron scattering data.

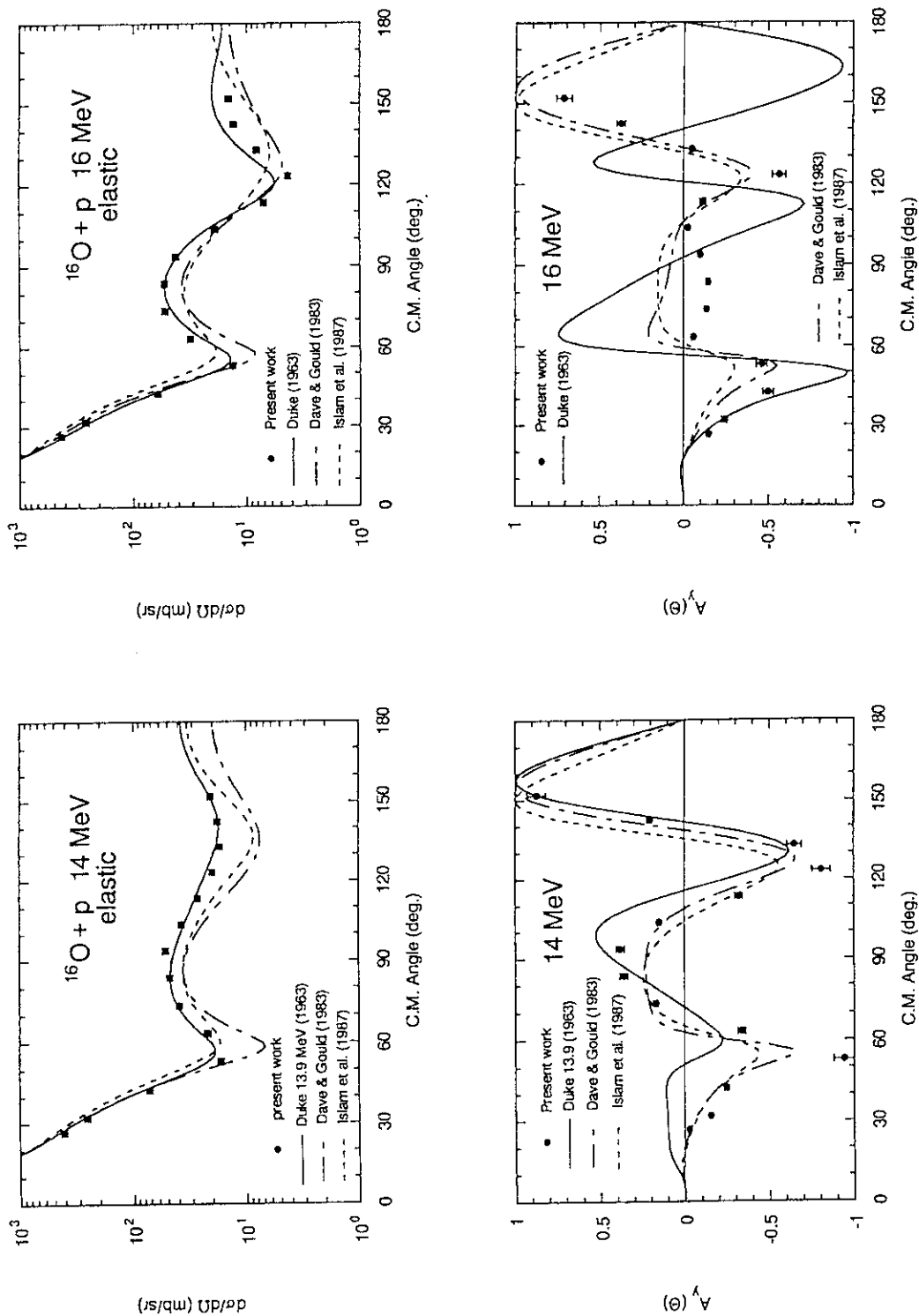

Fig.7 Comparison of the measured cross sections and analyzing powers with the calculated ones by using the potential parameters of Duke, Dave and Gould, and Islam et al.

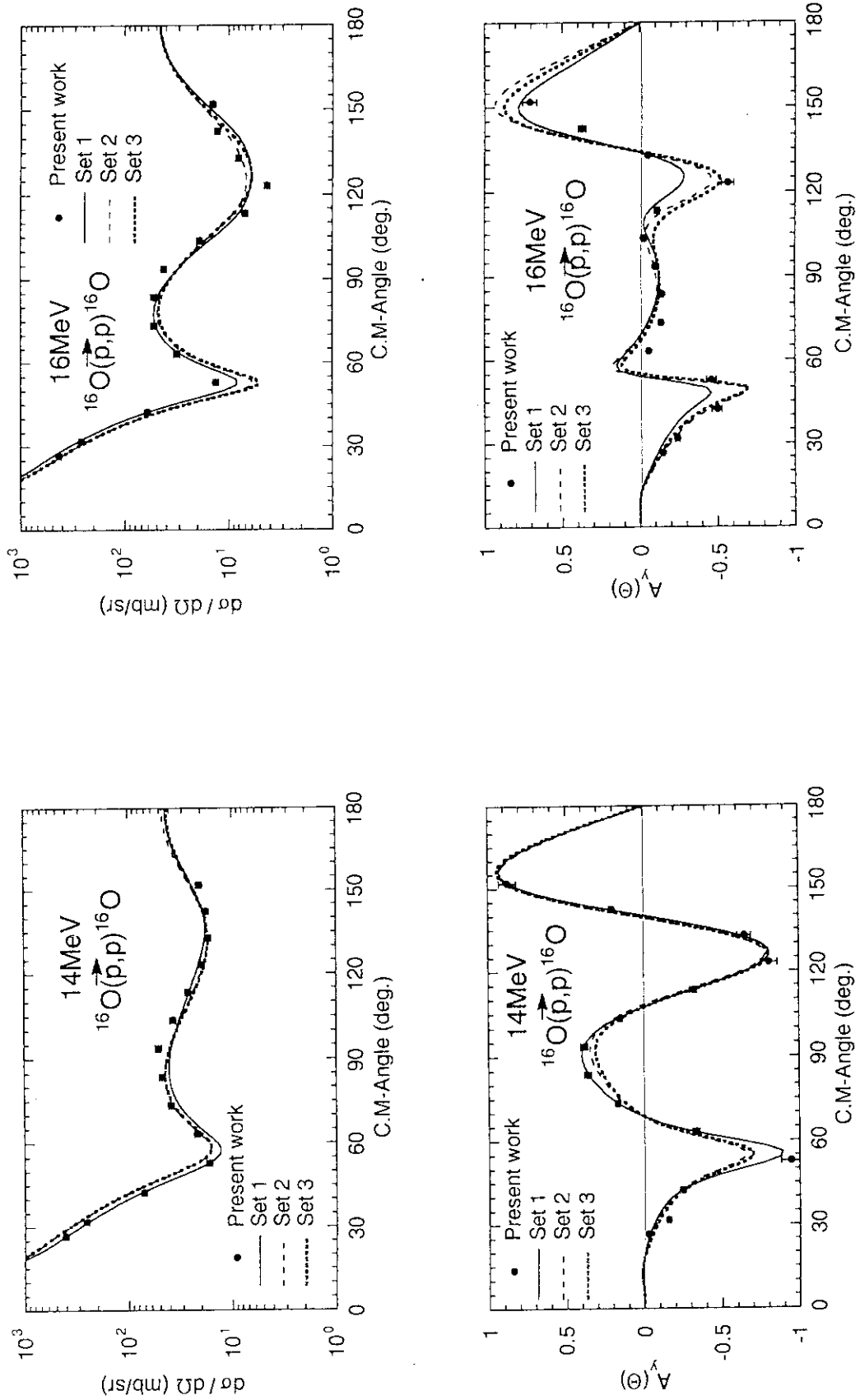

Fig. 8 Comparison of the measured cross sections and analyzing powers with the calculated ones with the searched parameter sets for the elastic scattering.

Appendices:

- Appendix 1 Double differential cross sections of the $^{16}\text{O}(p,p'x)$ reaction at 14 MeV.
Numerical data.
- Appendix 2 Double differential cross sections of the $^{16}\text{O}(p,p'x)$ reaction at 16 MeV.
Numerical data.
- Appendix 3 Differential cross sections and analyzing powers of the elastic and inelastic scattering in the $p + ^{16}\text{O}$ interaction at 14 MeV.
Numerical data.
- Appendix 4 Differential cross sections and analyzing powers of the elastic and inelastic scattering in the $p + ^{16}\text{O}$ interaction at 16 MeV.
Numerical data.

Appendix 1 Double differential cross sections of the $^{16}\text{O}(p,p'x)$ reaction at 14 MeV.

<< $^{16}\text{O}(p,p'x)$ $E_p = 14$ MeV >> *** DDX (error) in [mb/MeV \cdot sr] ***

$E_{p'}$ (MeV)	30 deg.	40 deg.	50 deg.
3.0 -- 3.1	6.336E-01 (4.579E-02)	4.702E-01 (5.282E-02)	6.257E-01 (5.953E-02)
3.1 -- 3.2	1.566E+00 (7.273E-02)	6.911E-01 (6.392E-02)	4.972E-01 (5.273E-02)
3.2 -- 3.3	3.026E+00 (9.950E-02)	1.113E+00 (8.090E-02)	7.676E-01 (6.547E-02)
3.3 -- 3.4	3.198E+00 (1.022E-01)	1.556E+00 (9.416E-02)	1.026E+00 (7.502E-02)
3.4 -- 3.5	3.328E+00 (1.037E-01)	1.510E+00 (9.344E-02)	2.190E+00 (1.115E-01)
3.5 -- 3.6	3.453E+00 (1.051E-01)	2.539E+00 (1.207E-01)	7.244E+00 (2.007E-01)
3.6 -- 3.7	5.991E+00 (1.400E-01)	8.239E+00 (2.178E-01)	3.649E+00 (1.391E-01)
3.7 -- 3.8	1.203E+01 (1.970E-01)	5.076E+00 (1.678E-01)	1.669E+00 (9.522E-02)
3.8 -- 3.9	5.933E+00 (1.371E-01)	2.116E+00 (1.090E-01)	2.053E+00 (1.070E-01)
3.9 -- 4.0	4.026E+00 (1.136E-01)	2.249E+00 (1.122E-01)	1.638E+00 (9.443E-02)
4.0 -- 4.1	4.146E+00 (1.147E-01)	2.289E+00 (1.123E-01)	1.285E+00 (8.305E-02)
4.1 -- 4.2	4.101E+00 (1.145E-01)	1.700E+00 (9.669E-02)	1.100E+00 (7.666E-02)
4.2 -- 4.3	3.373E+00 (1.037E-01)	1.583E+00 (9.379E-02)	7.483E-01 (6.364E-02)
4.3 -- 4.4	3.105E+00 (9.952E-02)	1.250E+00 (8.473E-02)	7.135E-01 (6.318E-02)
4.4 -- 4.5	2.877E+00 (9.626E-02)	1.006E+00 (7.530E-02)	1.943E+00 (1.061E-01)
4.5 -- 4.6	2.737E+00 (9.415E-02)	1.476E+00 (9.351E-02)	1.487E+01 (2.877E-01)
4.6 -- 4.7	4.855E+00 (1.273E-01)	1.484E+01 (2.944E-01)	1.099E+01 (2.430E-01)
4.7 -- 4.8	2.295E+01 (2.736E-01)	1.843E+01 (3.225E-01)	1.298E+00 (8.253E-02)
4.8 -- 4.9	1.771E+01 (2.383E-01)	2.879E+00 (1.258E-01)	6.144E-01 (5.786E-02)
4.9 -- 5.0	4.192E+00 (1.151E-01)	1.171E+00 (8.056E-02)	6.314E-01 (5.777E-02)
5.0 -- 5.1	2.991E+00 (9.852E-02)	9.427E-01 (7.210E-02)	4.274E-01 (4.709E-02)
5.1 -- 5.2	2.738E+00 (9.371E-02)	9.646E-01 (7.334E-02)	3.279E-01 (4.274E-02)
5.2 -- 5.3	2.666E+00 (9.251E-02)	8.764E-01 (7.117E-02)	4.874E-01 (5.157E-02)
5.3 -- 5.4	2.598E+00 (9.148E-02)	8.269E-01 (6.799E-02)	3.568E-01 (4.434E-02)
5.4 -- 5.5	2.565E+00 (9.055E-02)	7.512E-01 (6.527E-02)	4.310E-01 (4.869E-02)
5.5 -- 5.6	2.580E+00 (9.064E-02)	7.224E-01 (6.384E-02)	5.702E-01 (5.682E-02)
5.6 -- 5.7	2.405E+00 (8.797E-02)	9.223E-01 (7.245E-02)	6.276E-01 (5.887E-02)
5.7 -- 5.8	2.337E+00 (8.660E-02)	8.281E-01 (6.833E-02)	7.802E-01 (6.584E-02)
5.8 -- 5.9	2.487E+00 (8.997E-02)	7.865E-01 (6.623E-02)	6.281E-01 (5.783E-02)
5.9 -- 6.0	2.368E+00 (8.791E-02)	6.908E-01 (6.188E-02)	5.452E-01 (5.367E-02)
6.0 -- 6.1	2.278E+00 (8.648E-02)	6.892E-01 (6.183E-02)	4.430E-01 (4.918E-02)
6.1 -- 6.2	2.218E+00 (8.452E-02)	6.844E-01 (6.189E-02)	4.157E-01 (4.815E-02)
6.2 -- 6.3	2.240E+00 (8.514E-02)	7.672E-01 (6.515E-02)	6.492E+00 (1.956E-01)
6.3 -- 6.4	2.200E+00 (8.450E-02)	2.283E+00 (1.176E-01)	4.328E+01 (4.923E-01)
6.4 -- 6.5	3.955E+00 (1.149E-01)	3.119E+01 (4.302E-01)	2.310E+01 (3.569E-01)
6.5 -- 6.6	3.028E+01 (3.207E-01)	4.140E+01 (4.868E-01)	1.939E+01 (3.267E-01)
6.6 -- 6.7	3.585E+01 (3.404E-01)	1.677E+01 (3.091E-01)	9.618E+00 (2.269E-01)
6.7 -- 6.8	1.773E+01 (2.396E-01)	1.851E+01 (3.230E-01)	1.433E+00 (8.738E-02)
6.8 -- 6.9	1.802E+01 (2.402E-01)	3.598E+00 (1.397E-01)	7.368E-01 (6.311E-02)
6.9 -- 7.0	4.444E+00 (1.184E-01)	1.179E+00 (8.274E-02)	4.828E-01 (5.109E-02)
7.0 -- 7.1	2.688E+00 (9.295E-02)	1.102E+00 (7.990E-02)	5.204E-01 (5.332E-02)
7.1 -- 7.2	2.348E+00 (8.721E-02)	9.297E-01 (7.261E-02)	5.710E-01 (5.670E-02)
7.2 -- 7.3	2.293E+00 (8.615E-02)	1.003E+00 (7.499E-02)	1.043E+01 (2.523E-01)
7.3 -- 7.4	2.274E+00 (8.584E-02)	2.900E+00 (1.315E-01)	5.351E+01 (5.556E-01)
7.4 -- 7.5	5.067E+00 (1.308E-01)	3.986E+01 (4.944E-01)	3.370E+01 (4.327E-01)
7.5 -- 7.6	4.726E+01 (4.034E-01)	5.799E+01 (5.777E-01)	5.469E+00 (1.733E-01)
7.6 -- 7.7	6.834E+01 (4.710E-01)	1.485E+01 (2.900E-01)	1.266E+00 (8.413E-02)
7.7 -- 7.8	1.722E+01 (2.351E-01)	2.359E+00 (1.157E-01)	7.120E-01 (6.211E-02)
7.8 -- 7.9	4.260E+00 (1.172E-01)	1.315E+00 (8.625E-02)	6.334E-01 (5.817E-02)
7.9 -- 8.0	2.986E+00 (9.843E-02)	1.299E+00 (8.651E-02)	3.991E-01 (4.676E-02)

<< 160(p,p'x) Ep = 14 MeV >> *** DDX (error) in [mb/MeV*sr] ***

Ep' (MeV)	30 deg.	40 deg.	50 deg.
8.0 -- 8.1	2.410E+00(8.801E-02)	1.244E+00(8.446E-02)	4.521E-01(4.997E-02)
8.1 -- 8.2	2.259E+00(8.603E-02)	1.449E+00(9.168E-02)	3.557E-01(4.405E-02)
8.2 -- 8.3	2.086E+00(8.207E-02)	1.139E+00(7.997E-02)	3.052E-01(4.101E-02)
8.3 -- 8.4	1.934E+00(7.925E-02)	9.131E-01(7.225E-02)	2.710E-01(3.840E-02)
8.4 -- 8.5	1.873E+00(7.872E-02)	6.384E-01(5.907E-02)	3.054E-01(4.061E-02)
8.5 -- 8.6	1.683E+00(7.402E-02)	7.799E-01(6.601E-02)	2.271E-01(3.545E-02)
8.6 -- 8.7	2.026E+00(8.084E-02)	5.454E-01(5.569E-02)	2.156E-01(3.489E-02)
8.7 -- 8.8	1.892E+00(7.827E-02)	5.959E-01(5.676E-02)	2.274E-01(3.445E-02)
8.8 -- 8.9	1.547E+00(7.057E-02)	4.205E-01(4.807E-02)	2.832E-01(3.937E-02)
8.9 -- 9.0	1.640E+00(7.272E-02)	6.052E-01(5.871E-02)	1.922E-01(3.227E-02)
9.0 -- 9.1	1.604E+00(7.198E-02)	5.839E-01(5.664E-02)	2.193E-01(3.367E-02)
9.1 -- 9.2	1.612E+00(7.189E-02)	6.109E-01(5.855E-02)	1.200E-01(2.495E-02)
9.2 -- 9.3	1.709E+00(7.426E-02)	4.273E-01(4.933E-02)	1.454E-01(2.758E-02)
9.3 -- 9.4	1.480E+00(6.909E-02)	5.009E-01(5.245E-02)	1.266E-01(2.671E-02)
9.4 -- 9.5	1.430E+00(6.800E-02)	3.434E-01(4.380E-02)	1.247E-01(2.650E-02)
9.5 -- 9.6	1.359E+00(6.616E-02)	4.437E-01(4.981E-02)	1.159E-01(2.459E-02)
9.6 -- 9.7	1.355E+00(6.637E-02)	4.248E-01(4.901E-02)	9.961E-02(2.149E-02)
9.7 -- 9.8	1.381E+00(6.693E-02)	3.949E-01(4.724E-02)	1.774E-01(3.063E-02)
9.8 -- 9.9	1.397E+00(6.739E-02)	3.326E-01(4.199E-02)	1.597E-01(2.977E-02)
9.9 -- 10.0	1.231E+00(6.306E-02)	3.867E-01(4.677E-02)	1.505E-01(2.775E-02)
10.0 -- 10.1	1.297E+00(6.492E-02)	3.808E-01(4.715E-02)	9.866E-02(2.243E-02)
10.1 -- 10.2	1.454E+00(6.894E-02)	4.162E-01(4.781E-02)	6.562E-02(1.742E-02)
10.2 -- 10.3	1.793E+00(7.626E-02)	4.101E-01(4.711E-02)	7.447E-02(1.879E-02)
10.3 -- 10.4	2.311E+00(8.663E-02)	4.138E-01(4.872E-02)	6.882E-02(1.944E-02)
10.4 -- 10.5	2.404E+00(8.844E-02)	4.028E-01(4.830E-02)	9.939E-02(2.261E-02)
10.5 -- 10.6	1.851E+00(7.707E-02)	2.793E-01(3.947E-02)	8.300E-02(2.061E-02)
10.6 -- 10.7	1.449E+00(6.891E-02)	3.155E-01(4.187E-02)	7.455E-02(2.013E-02)
10.7 -- 10.8	1.134E+00(6.012E-02)	3.274E-01(4.154E-02)	1.122E-01(2.445E-02)
10.8 -- 10.9	1.247E+00(6.396E-02)	3.730E-01(4.561E-02)	1.411E-01(2.764E-02)
10.9 -- 11.0	9.837E-01(5.611E-02)	3.381E-01(4.381E-02)	9.661E-02(2.270E-02)
11.0 -- 11.1	1.028E+00(5.803E-02)	3.713E-01(4.476E-02)	8.371E-02(2.022E-02)
11.1 -- 11.2	1.130E+00(6.058E-02)	3.798E-01(4.577E-02)	8.412E-02(2.016E-02)
11.2 -- 11.3	1.004E+00(5.668E-02)	3.348E-01(4.313E-02)	7.040E-02(1.902E-02)
11.3 -- 11.4	1.050E+00(5.815E-02)	3.860E-01(4.664E-02)	1.305E-01(2.576E-02)
11.4 -- 11.5	1.187E+00(6.224E-02)	3.372E-01(4.310E-02)	2.152E-01(3.415E-02)
11.5 -- 11.6	1.107E+00(5.922E-02)	3.942E-01(4.739E-02)	3.906E-01(4.586E-02)
11.6 -- 11.7	1.337E+00(6.492E-02)	8.582E-01(6.975E-02)	7.210E-01(6.131E-02)
11.7 -- 11.8	1.985E+00(8.052E-02)	7.312E-01(6.442E-02)	3.829E-01(4.433E-02)
11.8 -- 11.9	2.483E+00(8.929E-02)	4.148E-01(4.733E-02)	1.152E-01(2.260E-02)
11.9 -- 12.0	1.781E+00(7.588E-02)	3.768E-01(4.524E-02)	7.225E-02(1.839E-02)
12.0 -- 12.1	1.212E+00(6.182E-02)	2.865E-01(4.044E-02)	9.264E-02(2.050E-02)
12.1 -- 12.2	1.069E+00(5.885E-02)	4.161E-01(4.804E-02)	9.796E-02(2.143E-02)
12.2 -- 12.3	1.235E+00(6.317E-02)	4.210E-01(4.868E-02)	1.278E-01(2.633E-02)
12.3 -- 12.4	1.140E+00(6.032E-02)	1.101E+00(7.912E-02)	1.136E-01(2.328E-02)
12.4 -- 12.5	1.214E+00(6.244E-02)	1.179E+00(7.998E-02)	1.372E-01(2.536E-02)
12.5 -- 12.6	1.219E+00(6.278E-02)	6.709E-01(6.067E-02)	1.169E-01(2.495E-02)
12.6 -- 12.7	1.269E+00(6.347E-02)	4.907E-01(5.190E-02)	1.346E-01(2.529E-02)
12.7 -- 12.8	1.461E+00(6.820E-02)	6.172E-01(5.939E-02)	1.936E-01(3.132E-02)
12.8 -- 12.9	1.834E+00(7.717E-02)	8.575E-01(6.817E-02)	2.755E-01(3.697E-02)
12.9 -- 13.0	2.848E+00(9.528E-02)	1.046E+00(7.652E-02)	3.410E-01(4.135E-02)

<< 160(p,p'x) Ep = 14 MeV >> *** DDX (error) in [mb/MeV*sr] ***

Ep' (MeV)	30 deg.	40 deg.	50 deg.
13.0 -- 13.1	4.326E+00(1.176E-01)	1.369E+00(8.833E-02)	2.970E-01(3.796E-02)
13.1 -- 13.2	4.006E+00(1.131E-01)	1.270E+00(8.355E-02)	5.228E-01(5.236E-02)
13.2 -- 13.3	4.350E+00(1.183E-01)	1.118E+00(7.848E-02)	1.151E+01(2.488E-01)
13.3 -- 13.4	4.250E+00(1.170E-01)	2.211E+00(1.118E-01)	1.008E+02(9.429E-01)
13.4 -- 13.5	5.220E+00(1.304E-01)	6.679E+01(6.256E-01)	6.233E+01(7.471E-01)
13.5 -- 13.6	5.533E+01(4.416E-01)	4.608E+02(1.758E+00)	5.335E+00(1.654E-01)
13.6 -- 13.7	9.664E+02(1.889E+00)	2.256E+02(1.421E+00)	1.841E+00(9.597E-02)
13.7 -- 13.8	1.223E+03(2.062E+00)	1.994E+01(3.362E-01)	1.214E+00(7.783E-02)
13.8 -- 13.9	1.962E+02(9.496E-01)	7.385E+00(2.026E-01)	8.390E-01(6.430E-02)
13.9 -- 14.0	4.119E+01(3.656E-01)	4.314E+00(1.551E-01)	5.340E-01(5.182E-02)
14.0 -- 14.1	2.232E+01(2.679E-01)	3.070E+00(1.308E-01)	4.711E-01(4.821E-02)
14.1 -- 14.2	1.445E+01(2.153E-01)	2.211E+00(1.100E-01)	2.629E-01(3.648E-02)
14.2 -- 14.3	1.089E+01(1.873E-01)	1.648E+00(9.537E-02)	2.524E-01(3.428E-02)
14.3 -- 14.4	***** (*****)	***** (*****)	***** (*****)
14.4 -- 14.5	***** (*****)	***** (*****)	***** (*****)
14.5 -- 14.6	***** (*****)	***** (*****)	***** (*****)
14.6 -- 14.7	***** (*****)	***** (*****)	***** (*****)
14.7 -- 14.8	***** (*****)	***** (*****)	***** (*****)
14.8 -- 14.9	***** (*****)	***** (*****)	***** (*****)
14.9 -- 15.0	***** (*****)	***** (*****)	***** (*****)

<< 160(p,p'x) Ep = 14 MeV >> *** DDX (error) in [mb/MeV*sr] ***

Ep' (MeV)	60 deg.	70 deg.	80 deg.
3.0 -- 3.1	5.361E-01(5.600E-02)	5.273E-01(5.816E-02)	6.168E-01(7.213E-02)
3.1 -- 3.2	5.336E-01(5.608E-02)	8.421E-01(7.571E-02)	6.924E-01(7.691E-02)
3.2 -- 3.3	9.280E-01(7.459E-02)	3.442E+00(1.538E-01)	7.980E-01(8.265E-02)
3.3 -- 3.4	4.088E+00(1.563E-01)	2.660E+00(1.326E-01)	1.238E+00(1.032E-01)
3.4 -- 3.5	5.727E+00(1.822E-01)	1.564E+00(1.030E-01)	1.470E+00(1.123E-01)
3.5 -- 3.6	2.076E+00(1.100E-01)	1.689E+00(1.066E-01)	1.397E+00(1.088E-01)
3.6 -- 3.7	1.806E+00(1.028E-01)	1.562E+00(1.024E-01)	9.087E-01(8.711E-02)
3.7 -- 3.8	1.569E+00(9.467E-02)	1.162E+00(8.848E-02)	9.146E-01(8.759E-02)
3.8 -- 3.9	1.440E+00(9.093E-02)	1.058E+00(8.377E-02)	7.378E-01(7.897E-02)
3.9 -- 4.0	1.137E+00(8.161E-02)	7.535E-01(7.128E-02)	1.243E+00(1.049E-01)
4.0 -- 4.1	8.589E-01(6.967E-02)	6.362E-01(6.417E-02)	1.124E+01(3.112E-01)
4.1 -- 4.2	6.595E-01(6.158E-02)	2.134E+00(1.216E-01)	1.480E+01(3.496E-01)
4.2 -- 4.3	7.545E-01(6.729E-02)	1.393E+01(3.066E-01)	1.857E+00(1.225E-01)
4.3 -- 4.4	6.771E+00(2.011E-01)	7.883E+00(2.248E-01)	8.012E-01(8.118E-02)
4.4 -- 4.5	1.477E+01(2.907E-01)	1.095E+00(8.472E-02)	4.971E-01(6.462E-02)
4.5 -- 4.6	2.846E+00(1.245E-01)	6.561E-01(6.510E-02)	5.184E-01(6.612E-02)
4.6 -- 4.7	7.735E-01(6.653E-02)	4.478E-01(5.377E-02)	4.622E-01(6.195E-02)
4.7 -- 4.8	5.587E-01(5.652E-02)	4.538E-01(5.599E-02)	4.901E-01(6.505E-02)
4.8 -- 4.9	3.616E-01(4.530E-02)	4.967E-01(5.741E-02)	3.906E-01(5.784E-02)
4.9 -- 5.0	3.501E-01(4.536E-02)	5.084E-01(5.836E-02)	4.349E-01(6.175E-02)
5.0 -- 5.1	3.399E-01(4.482E-02)	3.894E-01(5.209E-02)	4.039E-01(5.905E-02)
5.1 -- 5.2	3.535E-01(4.509E-02)	3.393E-01(4.835E-02)	4.651E-01(6.278E-02)
5.2 -- 5.3	3.923E-01(4.682E-02)	4.323E-01(5.392E-02)	3.463E-01(5.465E-02)
5.3 -- 5.4	3.126E-01(4.165E-02)	3.419E-01(4.772E-02)	2.940E-01(4.963E-02)
5.4 -- 5.5	3.158E-01(4.286E-02)	4.306E-01(5.440E-02)	3.039E-01(5.183E-02)
5.5 -- 5.6	3.095E-01(4.262E-02)	4.108E-01(5.299E-02)	4.433E-01(6.168E-02)
5.6 -- 5.7	3.793E-01(4.766E-02)	3.494E-01(4.951E-02)	7.401E-01(8.129E-02)
5.7 -- 5.8	3.120E-01(4.332E-02)	3.640E-01(5.008E-02)	1.027E+01(3.038E-01)
5.8 -- 5.9	2.410E-01(3.703E-02)	9.776E-01(8.358E-02)	1.706E+01(3.820E-01)
5.9 -- 6.0	2.351E-01(3.712E-02)	1.515E+01(3.260E-01)	6.137E+00(2.276E-01)
6.0 -- 6.1	2.669E+00(1.279E-01)	2.367E+01(3.951E-01)	5.634E+00(2.160E-01)
6.1 -- 6.2	2.937E+01(4.161E-01)	8.336E+00(2.352E-01)	1.065E+00(9.362E-02)
6.2 -- 6.3	2.393E+01(3.718E-01)	8.342E+00(2.350E-01)	6.102E-01(7.186E-02)
6.3 -- 6.4	1.288E+01(2.731E-01)	1.514E+00(9.846E-02)	4.668E-01(6.320E-02)
6.4 -- 6.5	9.558E+00(2.324E-01)	6.273E-01(6.487E-02)	4.392E-01(6.107E-02)
6.5 -- 6.6	1.215E+00(8.219E-02)	5.909E-01(6.372E-02)	3.592E-01(5.601E-02)
6.6 -- 6.7	6.697E-01(6.134E-02)	4.981E-01(5.793E-02)	4.944E+00(2.127E-01)
6.7 -- 6.8	5.085E-01(5.454E-02)	4.449E-01(5.580E-02)	3.543E+01(5.543E-01)
6.8 -- 6.9	4.782E-01(5.314E-02)	4.134E+00(1.727E-01)	2.485E+01(4.534E-01)
6.9 -- 7.0	4.593E-01(5.171E-02)	3.624E+01(5.037E-01)	3.782E+00(1.761E-01)
7.0 -- 7.1	7.468E+00(2.179E-01)	3.358E+01(4.723E-01)	8.665E-01(8.452E-02)
7.1 -- 7.2	4.630E+01(5.302E-01)	6.712E+00(2.092E-01)	5.236E-01(6.710E-02)
7.2 -- 7.3	3.371E+01(4.438E-01)	1.279E+00(9.187E-02)	4.372E-01(6.020E-02)
7.3 -- 7.4	5.463E+00(1.752E-01)	6.969E-01(6.837E-02)	2.594E-01(4.648E-02)
7.4 -- 7.5	1.182E+00(8.289E-02)	5.284E-01(5.849E-02)	3.106E-01(5.119E-02)
7.5 -- 7.6	5.876E-01(5.818E-02)	4.886E-01(5.731E-02)	4.582E-01(6.295E-02)
7.6 -- 7.7	4.930E-01(5.350E-02)	3.768E-01(5.073E-02)	3.518E-01(5.549E-02)
7.7 -- 7.8	4.376E-01(5.044E-02)	3.334E-01(4.777E-02)	2.328E-01(4.435E-02)
7.8 -- 7.9	4.414E-01(5.033E-02)	3.040E-01(4.541E-02)	3.348E-01(5.401E-02)
7.9 -- 8.0	2.975E-01(4.175E-02)	3.257E-01(4.648E-02)	2.926E-01(5.076E-02)

<< 160(p,p'x) Ep = 14 MeV >> *** DDX (error) in [mb/MeV*sr] ***

Ep' (MeV)	60 deg.	70 deg.	80 deg.
8.0 -- 8.1	2.951E-01(4.131E-02)	2.755E-01(4.256E-02)	2.807E-01(4.876E-02)
8.1 -- 8.2	2.778E-01(4.013E-02)	2.867E-01(4.326E-02)	2.240E-01(4.399E-02)
8.2 -- 8.3	2.344E-01(3.753E-02)	3.260E-01(4.705E-02)	2.652E-01(4.823E-02)
8.3 -- 8.4	2.511E-01(3.709E-02)	2.382E-01(4.071E-02)	1.858E-01(4.042E-02)
8.4 -- 8.5	1.728E-01(3.248E-02)	2.049E-01(3.695E-02)	2.533E-01(4.676E-02)
8.5 -- 8.6	2.603E-01(3.944E-02)	2.271E-01(3.964E-02)	1.963E-01(4.140E-02)
8.6 -- 8.7	2.579E-01(3.778E-02)	1.999E-01(3.752E-02)	1.803E-01(4.000E-02)
8.7 -- 8.8	1.798E-01(3.161E-02)	2.576E-01(4.106E-02)	1.493E-01(3.510E-02)
8.8 -- 8.9	1.611E-01(2.983E-02)	1.985E-01(3.738E-02)	1.635E-01(3.733E-02)
8.9 -- 9.0	1.265E-01(2.729E-02)	1.701E-01(3.401E-02)	2.411E-01(4.587E-02)
9.0 -- 9.1	1.432E-01(2.913E-02)	2.177E-01(3.806E-02)	2.318E-01(4.460E-02)
9.1 -- 9.2	1.579E-01(3.059E-02)	2.636E-01(4.315E-02)	1.975E-01(3.993E-02)
9.2 -- 9.3	1.435E-01(2.768E-02)	1.724E-01(3.354E-02)	2.230E-01(4.411E-02)
9.3 -- 9.4	1.247E-01(2.548E-02)	1.046E-01(2.614E-02)	2.087E-01(4.227E-02)
9.4 -- 9.5	1.247E-01(2.628E-02)	1.607E-01(3.367E-02)	1.153E-01(3.240E-02)
9.5 -- 9.6	9.291E-02(2.321E-02)	1.409E-01(3.136E-02)	1.970E-01(4.066E-02)
9.6 -- 9.7	9.186E-02(2.279E-02)	1.748E-01(3.523E-02)	1.772E-01(3.930E-02)
9.7 -- 9.8	1.203E-01(2.588E-02)	1.824E-01(3.503E-02)	1.823E-01(3.869E-02)
9.8 -- 9.9	7.777E-02(2.054E-02)	1.253E-01(2.919E-02)	1.681E-01(3.917E-02)
9.9 -- 10.0	9.705E-02(2.384E-02)	2.384E-01(3.964E-02)	1.897E-01(4.088E-02)
10.0 -- 10.1	5.868E-02(1.745E-02)	2.766E-01(4.223E-02)	1.777E-01(3.968E-02)
10.1 -- 10.2	6.350E-02(1.834E-02)	1.674E-01(3.443E-02)	2.038E-01(4.232E-02)
10.2 -- 10.3	1.066E-01(2.445E-02)	1.306E-01(2.984E-02)	2.130E-01(4.372E-02)
10.3 -- 10.4	4.593E-02(1.623E-02)	1.944E-01(3.624E-02)	1.301E-01(3.340E-02)
10.4 -- 10.5	9.073E-02(2.234E-02)	2.340E-01(3.985E-02)	2.451E-01(4.638E-02)
10.5 -- 10.6	6.692E-02(1.973E-02)	1.868E-01(3.597E-02)	2.696E-01(4.841E-02)
10.6 -- 10.7	1.255E-01(2.717E-02)	1.382E-01(3.041E-02)	3.153E-01(5.309E-02)
10.7 -- 10.8	2.386E-01(3.710E-02)	1.806E-01(3.540E-02)	4.139E-01(6.002E-02)
10.8 -- 10.9	4.105E-01(4.740E-02)	1.676E-01(3.375E-02)	3.132E-01(5.249E-02)
10.9 -- 11.0	1.919E-01(3.279E-02)	3.442E-01(4.815E-02)	1.974E-01(3.997E-02)
11.0 -- 11.1	1.165E-01(2.572E-02)	3.525E-01(4.971E-02)	1.857E-01(4.042E-02)
11.1 -- 11.2	9.427E-02(2.339E-02)	2.433E-01(4.009E-02)	1.687E-01(3.870E-02)
11.2 -- 11.3	2.315E-01(3.686E-02)	1.707E-01(3.387E-02)	2.176E-01(4.297E-02)
11.3 -- 11.4	2.203E-01(3.512E-02)	1.650E-01(3.399E-02)	2.563E-01(4.822E-02)
11.4 -- 11.5	8.430E-02(2.098E-02)	2.117E-01(3.831E-02)	2.090E-01(4.341E-02)
11.5 -- 11.6	6.751E-02(1.866E-02)	1.192E-01(2.808E-02)	1.976E-01(4.143E-02)
11.6 -- 11.7	9.528E-02(2.367E-02)	1.427E-01(3.101E-02)	3.472E-01(5.545E-02)
11.7 -- 11.8	7.583E-02(2.068E-02)	1.598E-01(3.324E-02)	2.532E-01(4.742E-02)
11.8 -- 11.9	8.889E-02(2.298E-02)	1.461E-01(3.160E-02)	2.870E-01(4.970E-02)
11.9 -- 12.0	6.747E-02(1.996E-02)	2.244E-01(3.855E-02)	6.381E-01(7.610E-02)
12.0 -- 12.1	9.350E-02(2.209E-02)	2.781E-01(4.330E-02)	6.431E-01(7.423E-02)
12.1 -- 12.2	1.467E-01(2.752E-02)	4.125E-01(5.327E-02)	7.470E-01(8.055E-02)
12.2 -- 12.3	1.819E-01(3.127E-02)	4.845E-01(5.827E-02)	8.260E-01(8.514E-02)
12.3 -- 12.4	2.433E-01(3.818E-02)	4.545E-01(5.618E-02)	9.891E-01(9.341E-02)
12.4 -- 12.5	2.686E-01(3.858E-02)	5.971E-01(6.366E-02)	1.591E+01(3.893E-01)
12.5 -- 12.6	2.935E-01(4.125E-02)	5.035E-01(5.855E-02)	2.206E+02(1.604E+00)
12.6 -- 12.7	3.552E-01(4.500E-02)	1.159E+00(8.942E-02)	2.098E+02(1.367E+00)
12.7 -- 12.8	3.211E-01(4.262E-02)	3.197E+01(4.918E-01)	2.037E+01(4.147E-01)
12.8 -- 12.9	3.232E-01(4.244E-02)	2.301E+02(1.311E+00)	4.850E+00(2.043E-01)
12.9 -- 13.0	3.449E+00(1.444E-01)	1.219E+02(9.036E-01)	2.472E+00(1.464E-01)

<< 160(p,p'x) Ep = 14 MeV >> *** DDX (error) in [mb/MeV*sr] ***

Ep' (MeV)	60 deg.	70 deg.	80 deg.
13.0 -- 13.1	7.718E+01(6.718E-01)	9.908E+00(2.564E-01)	1.563E+00(1.149E-01)
13.1 -- 13.2	1.299E+02(9.454E-01)	3.465E+00(1.527E-01)	1.311E+00(1.068E-01)
13.2 -- 13.3	1.719E+01(3.158E-01)	1.911E+00(1.130E-01)	9.108E-01(8.839E-02)
13.3 -- 13.4	2.782E+00(1.246E-01)	1.615E+00(1.054E-01)	8.265E-01(8.507E-02)
13.4 -- 13.5	1.480E+00(9.100E-02)	1.085E+00(8.522E-02)	5.797E-01(7.030E-02)
13.5 -- 13.6	9.884E-01(7.394E-02)	8.479E-01(7.448E-02)	6.208E-01(7.319E-02)
13.6 -- 13.7	9.380E-01(7.265E-02)	6.381E-01(6.542E-02)	4.498E-01(6.181E-02)
13.7 -- 13.8	5.824E-01(5.804E-02)	4.206E-01(5.354E-02)	3.853E-01(5.804E-02)
13.8 -- 13.9	2.703E-01(3.923E-02)	3.508E-01(4.965E-02)	2.524E-01(4.736E-02)
13.9 -- 14.0	2.695E-01(3.861E-02)	3.486E-01(4.911E-02)	1.551E-01(3.722E-02)
14.0 -- 14.1	3.538E-01(4.470E-02)	2.823E-01(4.333E-02)	1.284E-01(3.392E-02)
14.1 -- 14.2	2.374E-01(3.688E-02)	2.168E-01(3.876E-02)	1.643E-01(3.690E-02)
14.2 -- 14.3	1.503E-01(2.969E-02)	2.245E-01(3.995E-02)	1.276E-01(3.224E-02)
14.3 -- 14.4	***** (*****)	***** (*****)	***** (*****)
14.4 -- 14.5	***** (*****)	***** (*****)	***** (*****)
14.5 -- 14.6	***** (*****)	***** (*****)	***** (*****)
14.6 -- 14.7	***** (*****)	***** (*****)	***** (*****)
14.7 -- 14.8	***** (*****)	***** (*****)	***** (*****)
14.8 -- 14.9	***** (*****)	***** (*****)	***** (*****)
14.9 -- 15.0	***** (*****)	***** (*****)	***** (*****)

<< 16O(p,p'x) Ep = 14 MeV >> *** DDX (error) in [mb/MeV*sr] ***

Ep' (MeV)	90 deg.	100 deg.	110 deg.
3.0 -- 3.1	3.693E-01(5.112E-02)	3.636E-01(5.618E-02)	6.948E-01(7.468E-02)
3.1 -- 3.2	3.898E-01(5.108E-02)	3.973E-01(5.914E-02)	6.374E-01(7.046E-02)
3.2 -- 3.3	7.703E-01(7.477E-02)	5.232E-01(6.871E-02)	9.515E-01(8.855E-02)
3.3 -- 3.4	9.617E-01(8.353E-02)	7.007E-01(7.854E-02)	9.084E-01(8.444E-02)
3.4 -- 3.5	9.872E-01(8.483E-02)	5.197E-01(6.653E-02)	7.977E-01(8.029E-02)
3.5 -- 3.6	8.669E-01(7.868E-02)	6.689E-01(7.598E-02)	1.899E+00(1.284E-01)
3.6 -- 3.7	7.352E-01(7.246E-02)	5.682E-01(7.035E-02)	2.094E+01(4.211E-01)
3.7 -- 3.8	5.450E-01(6.190E-02)	6.906E+00(2.555E-01)	2.690E+01(4.651E-01)
3.8 -- 3.9	1.102E+00(8.950E-02)	3.045E+01(5.193E-01)	3.716E+00(1.698E-01)
3.9 -- 4.0	1.474E+01(3.277E-01)	9.526E+00(2.811E-01)	1.114E+00(9.611E-02)
4.0 -- 4.1	2.055E+01(3.745E-01)	8.177E-01(8.245E-02)	7.625E-01(7.792E-02)
4.1 -- 4.2	2.519E+00(1.277E-01)	4.798E-01(6.720E-02)	6.694E-01(7.472E-02)
4.2 -- 4.3	4.771E-01(5.699E-02)	4.230E-01(5.885E-02)	4.558E-01(5.995E-02)
4.3 -- 4.4	4.994E-01(5.936E-02)	3.836E-01(5.734E-02)	4.163E-01(5.770E-02)
4.4 -- 4.5	4.522E-01(5.619E-02)	3.126E-01(5.276E-02)	4.488E-01(6.041E-02)
4.5 -- 4.6	3.724E-01(5.170E-02)	3.250E-01(5.193E-02)	4.088E-01(5.713E-02)
4.6 -- 4.7	3.195E-01(4.666E-02)	3.104E-01(5.183E-02)	3.890E-01(5.572E-02)
4.7 -- 4.8	3.267E-01(4.856E-02)	2.624E-01(4.820E-02)	3.302E-01(5.163E-02)
4.8 -- 4.9	3.241E-01(4.643E-02)	2.542E-01(4.735E-02)	2.661E-01(4.592E-02)
4.9 -- 5.0	4.444E-01(5.711E-02)	2.564E-01(4.779E-02)	2.709E-01(4.551E-02)
5.0 -- 5.1	3.095E-01(4.682E-02)	2.326E-01(4.483E-02)	3.435E-01(5.306E-02)
5.1 -- 5.2	2.476E-01(4.221E-02)	3.483E-01(5.547E-02)	6.341E-01(7.302E-02)
5.2 -- 5.3	2.089E-01(3.855E-02)	2.807E-01(4.878E-02)	9.431E+00(2.938E-01)
5.3 -- 5.4	3.768E-01(5.209E-02)	1.116E+00(1.032E-01)	2.156E+01(4.347E-01)
5.4 -- 5.5	3.070E-01(4.663E-02)	1.426E+01(3.781E-01)	6.376E+00(2.257E-01)
5.5 -- 5.6	1.808E+00(1.175E-01)	1.602E+01(3.884E-01)	5.600E+00(2.068E-01)
5.6 -- 5.7	1.708E+01(3.658E-01)	4.905E+00(2.035E-01)	1.123E+00(9.164E-02)
5.7 -- 5.8	1.175E+01(2.927E-01)	3.709E+00(1.710E-01)	5.367E-01(6.563E-02)
5.8 -- 5.9	5.132E+00(1.878E-01)	5.736E-01(7.117E-02)	3.637E-01(5.397E-02)
5.9 -- 6.0	2.909E+00(1.385E-01)	2.683E-01(4.972E-02)	3.649E-01(5.493E-02)
6.0 -- 6.1	4.447E-01(5.671E-02)	2.208E-01(4.421E-02)	5.052E-01(6.553E-02)
6.1 -- 6.2	4.151E-01(5.510E-02)	1.829E-01(3.811E-02)	1.079E+01(2.989E-01)
6.2 -- 6.3	2.916E-01(4.427E-02)	6.548E-01(7.832E-02)	3.167E+01(5.040E-01)
6.3 -- 6.4	2.581E-01(4.279E-02)	1.721E+01(3.934E-01)	8.437E+00(2.550E-01)
6.4 -- 6.5	9.688E-01(8.467E-02)	3.202E+01(5.238E-01)	1.009E+00(8.749E-02)
6.5 -- 6.6	1.895E+01(3.699E-01)	4.010E+00(1.778E-01)	6.583E-01(7.288E-02)
6.6 -- 6.7	3.435E+01(4.857E-01)	4.692E-01(6.303E-02)	4.251E-01(5.810E-02)
6.7 -- 6.8	5.851E+00(1.968E-01)	3.342E-01(5.450E-02)	3.371E-01(5.240E-02)
6.8 -- 6.9	6.409E-01(6.646E-02)	2.818E-01(4.861E-02)	3.010E-01(4.849E-02)
6.9 -- 7.0	4.814E-01(5.808E-02)	2.669E-01(4.785E-02)	2.950E-01(4.902E-02)
7.0 -- 7.1	2.952E-01(4.584E-02)	2.094E-01(4.194E-02)	2.517E-01(4.433E-02)
7.1 -- 7.2	2.976E-01(4.571E-02)	1.790E-01(3.899E-02)	1.574E-01(3.605E-02)
7.2 -- 7.3	3.110E-01(4.674E-02)	1.324E-01(3.362E-02)	2.298E-01(4.322E-02)
7.3 -- 7.4	2.425E-01(4.165E-02)	2.015E-01(4.346E-02)	2.266E-01(4.283E-02)
7.4 -- 7.5	2.973E-01(4.526E-02)	2.439E-01(4.560E-02)	1.838E-01(3.751E-02)
7.5 -- 7.6	3.144E-01(4.738E-02)	2.531E-01(4.684E-02)	1.355E-01(3.136E-02)
7.6 -- 7.7	3.142E-01(4.758E-02)	2.256E-01(4.406E-02)	1.865E-01(3.853E-02)
7.7 -- 7.8	2.658E-01(4.381E-02)	1.930E-01(4.148E-02)	1.175E-01(3.049E-02)
7.8 -- 7.9	2.731E-01(4.379E-02)	1.418E-01(3.554E-02)	7.797E-02(2.428E-02)
7.9 -- 8.0	1.701E-01(3.449E-02)	1.706E-01(3.948E-02)	1.620E-01(3.564E-02)

<< 160(p,p'x) Ep = 14 MeV >> *** DDX (error) in [mb/MeV*sr] ***

Ep' (MeV)	90 deg.	100 deg.	110 deg.
8.0 -- 8.1	3.325E-01 (4.871E-02)	1.596E-01 (3.720E-02)	9.278E-02 (2.784E-02)
8.1 -- 8.2	2.421E-01 (4.205E-02)	1.454E-01 (3.587E-02)	1.145E-01 (3.062E-02)
8.2 -- 8.3	2.198E-01 (4.035E-02)	1.567E-01 (3.690E-02)	1.123E-01 (2.947E-02)
8.3 -- 8.4	2.278E-01 (4.111E-02)	1.189E-01 (3.161E-02)	9.547E-02 (2.666E-02)
8.4 -- 8.5	1.440E-01 (3.277E-02)	1.158E-01 (3.219E-02)	1.031E-01 (2.855E-02)
8.5 -- 8.6	1.892E-01 (3.730E-02)	8.436E-02 (2.683E-02)	9.460E-02 (2.679E-02)
8.6 -- 8.7	1.748E-01 (3.552E-02)	9.144E-02 (2.814E-02)	1.081E-01 (2.916E-02)
8.7 -- 8.8	1.990E-01 (3.755E-02)	1.410E-01 (3.611E-02)	5.341E-02 (1.918E-02)
8.8 -- 8.9	1.446E-01 (3.189E-02)	1.037E-01 (3.171E-02)	8.439E-02 (2.491E-02)
8.9 -- 9.0	1.899E-01 (3.635E-02)	1.173E-01 (3.265E-02)	8.986E-02 (2.645E-02)
9.0 -- 9.1	1.556E-01 (3.307E-02)	1.136E-01 (3.218E-02)	1.093E-01 (3.072E-02)
9.1 -- 9.2	1.825E-01 (3.687E-02)	1.249E-01 (3.273E-02)	9.024E-02 (2.611E-02)
9.2 -- 9.3	1.526E-01 (3.338E-02)	7.111E-02 (2.442E-02)	1.157E-01 (3.165E-02)
9.3 -- 9.4	1.303E-01 (3.072E-02)	1.442E-01 (3.679E-02)	1.091E-01 (2.843E-02)
9.4 -- 9.5	7.660E-02 (2.325E-02)	1.258E-01 (3.345E-02)	8.877E-02 (2.754E-02)
9.5 -- 9.6	6.402E-02 (2.205E-02)	1.109E-01 (3.199E-02)	1.603E-01 (3.527E-02)
9.6 -- 9.7	1.455E-01 (3.203E-02)	1.687E-01 (3.933E-02)	9.335E-02 (2.657E-02)
9.7 -- 9.8	1.824E-01 (3.598E-02)	1.062E-01 (3.063E-02)	1.027E-01 (2.713E-02)
9.8 -- 9.9	1.769E-01 (3.626E-02)	1.212E-01 (3.225E-02)	1.325E-01 (3.226E-02)
9.9 -- 10.0	1.565E-01 (3.380E-02)	1.499E-01 (3.645E-02)	1.137E-01 (2.960E-02)
10.0 -- 10.1	1.545E-01 (3.375E-02)	1.330E-01 (3.421E-02)	2.435E-01 (4.426E-02)
10.1 -- 10.2	2.208E-01 (4.064E-02)	1.696E-01 (3.914E-02)	1.284E-01 (3.172E-02)
10.2 -- 10.3	2.218E-01 (4.000E-02)	2.708E-01 (4.933E-02)	1.194E-01 (3.014E-02)
10.3 -- 10.4	1.655E-01 (3.443E-02)	1.920E-01 (4.049E-02)	1.050E-01 (2.950E-02)
10.4 -- 10.5	3.814E-01 (5.331E-02)	2.249E-01 (4.513E-02)	1.145E-01 (3.001E-02)
10.5 -- 10.6	3.646E-01 (5.200E-02)	1.257E-01 (3.244E-02)	1.596E-01 (3.576E-02)
10.6 -- 10.7	2.382E-01 (4.119E-02)	1.251E-01 (3.368E-02)	1.467E-01 (3.461E-02)
10.7 -- 10.8	1.459E-01 (3.186E-02)	1.508E-01 (3.600E-02)	1.022E-01 (2.760E-02)
10.8 -- 10.9	1.259E-01 (3.039E-02)	1.629E-01 (3.917E-02)	1.845E-01 (3.863E-02)
10.9 -- 11.0	1.996E-01 (3.869E-02)	2.428E-01 (4.655E-02)	1.386E-01 (3.132E-02)
11.0 -- 11.1	1.881E-01 (3.694E-02)	1.613E-01 (3.733E-02)	2.281E-01 (4.228E-02)
11.1 -- 11.2	1.533E-01 (3.311E-02)	1.167E-01 (3.196E-02)	3.189E-01 (4.925E-02)
11.2 -- 11.3	2.140E-01 (3.874E-02)	1.846E-01 (4.078E-02)	4.287E-01 (5.792E-02)
11.3 -- 11.4	2.436E-01 (4.255E-02)	3.382E-01 (5.439E-02)	4.539E-01 (6.003E-02)
11.4 -- 11.5	3.435E-01 (5.001E-02)	6.376E-01 (7.531E-02)	4.882E-01 (6.178E-02)
11.5 -- 11.6	3.352E-01 (5.095E-02)	6.879E-01 (7.660E-02)	4.940E-01 (6.213E-02)
11.6 -- 11.7	3.994E-01 (5.343E-02)	5.721E-01 (7.053E-02)	1.082E+00 (9.277E-02)
11.7 -- 11.8	5.564E-01 (6.356E-02)	5.268E-01 (6.804E-02)	4.038E+01 (5.738E-01)
11.8 -- 11.9	7.204E-01 (7.160E-02)	8.730E-01 (8.732E-02)	1.582E+02 (1.190E+00)
11.9 -- 12.0	6.427E-01 (6.898E-02)	1.800E+01 (4.160E-01)	4.733E+01 (6.440E-01)
12.0 -- 12.1	7.552E-01 (7.374E-02)	1.892E+02 (1.354E+00)	4.533E+00 (1.872E-01)
12.1 -- 12.2	1.922E+00 (1.191E-01)	1.357E+02 (1.087E+00)	2.318E+00 (1.342E-01)
12.2 -- 12.3	6.301E+01 (7.423E-01)	8.024E+00 (2.603E-01)	1.351E+00 (1.018E-01)
12.3 -- 12.4	2.812E+02 (1.615E+00)	1.527E+00 (1.149E-01)	9.356E-01 (8.625E-02)
12.4 -- 12.5	8.465E+01 (7.700E-01)	8.306E-01 (8.626E-02)	7.314E-01 (7.615E-02)
12.5 -- 12.6	4.903E+00 (1.853E-01)	5.567E-01 (7.050E-02)	5.490E-01 (6.527E-02)
12.6 -- 12.7	1.827E+00 (1.150E-01)	3.663E-01 (5.797E-02)	4.079E-01 (5.697E-02)
12.7 -- 12.8	1.054E+00 (8.715E-02)	2.685E-01 (4.847E-02)	2.138E-01 (4.019E-02)
12.8 -- 12.9	6.788E-01 (6.966E-02)	3.069E-01 (5.141E-02)	3.348E-01 (5.111E-02)
12.9 -- 13.0	5.875E-01 (6.443E-02)	2.215E-01 (4.361E-02)	2.326E-01 (4.325E-02)

<< 160(p,p'x) Ep = 14 MeV >> *** DDX (error) in [mb/MeV*sr] ***

Ep' (MeV)	90 deg.	100 deg.	110 deg.
13.0 -- 13.1	4.896E-01(5.937E-02)	1.274E-01(3.343E-02)	1.881E-01(3.864E-02)
13.1 -- 13.2	2.889E-01(4.631E-02)	1.482E-01(3.785E-02)	1.521E-01(3.406E-02)
13.2 -- 13.3	2.198E-01(4.004E-02)	1.009E-01(3.044E-02)	1.652E-01(3.497E-02)
13.3 -- 13.4	2.064E-01(3.866E-02)	7.736E-02(2.609E-02)	1.360E-01(3.241E-02)
13.4 -- 13.5	1.427E-01(3.170E-02)	5.766E-02(2.150E-02)	6.627E-02(2.272E-02)
13.5 -- 13.6	1.536E-01(3.324E-02)	3.613E-02(1.857E-02)	6.954E-02(2.269E-02)
13.6 -- 13.7	9.962E-02(2.706E-02)	3.520E-02(1.695E-02)	7.284E-02(2.450E-02)
13.7 -- 13.8	1.165E-01(2.899E-02)	2.946E-02(1.459E-02)	6.742E-02(2.387E-02)
13.8 -- 13.9	1.141E-01(2.842E-02)	3.773E-02(1.791E-02)	4.635E-02(1.838E-02)
13.9 -- 14.0	1.055E-01(2.833E-02)	1.600E-02(1.025E-02)	4.457E-02(1.876E-02)
14.0 -- 14.1	5.039E-02(1.862E-02)	2.178E-02(1.340E-02)	2.678E-02(1.306E-02)
14.1 -- 14.2	5.281E-02(1.943E-02)	8.350E-03(7.750E-03)	1.339E-02(9.230E-03)
14.2 -- 14.3	4.070E-02(1.814E-02)	1.562E-02(1.261E-02)	0.000E+00(0.000E+00)
14.3 -- 14.4	***** (*****)	***** (*****)	***** (*****)
14.4 -- 14.5	***** (*****)	***** (*****)	***** (*****)
14.5 -- 14.6	***** (*****)	***** (*****)	***** (*****)
14.6 -- 14.7	***** (*****)	***** (*****)	***** (*****)
14.7 -- 14.8	***** (*****)	***** (*****)	***** (*****)
14.8 -- 14.9	***** (*****)	***** (*****)	***** (*****)
14.9 -- 15.0	***** (*****)	***** (*****)	***** (*****)

<< 16O(p,p'x) Ep = 14 MeV >> *** DDX (error) in [mb/MeV*sr] ***

Ep' (MeV)	120 deg.	130 deg.	140 deg.
3.0 -- 3.1	7.912E-01(7.639E-02)	9.145E-01(7.840E-02)	7.722E-01(6.346E-02)
3.1 -- 3.2	1.038E+00(8.622E-02)	7.687E-01(7.174E-02)	6.784E-01(6.091E-02)
3.2 -- 3.3	1.077E+00(8.928E-02)	8.730E-01(7.805E-02)	6.032E+00(1.857E-01)
3.3 -- 3.4	9.721E-01(8.349E-02)	7.865E+00(2.390E-01)	2.376E+01(3.589E-01)
3.4 -- 3.5	5.673E+00(2.100E-01)	2.995E+01(4.531E-01)	8.191E+00(2.056E-01)
3.5 -- 3.6	3.117E+01(4.809E-01)	9.895E+00(2.520E-01)	1.128E+00(7.692E-02)
3.6 -- 3.7	1.361E+01(3.086E-01)	1.124E+00(8.487E-02)	6.614E-01(6.016E-02)
3.7 -- 3.8	1.679E+00(1.082E-01)	6.738E-01(6.762E-02)	4.568E-01(4.874E-02)
3.8 -- 3.9	8.735E-01(7.959E-02)	5.026E-01(5.749E-02)	3.845E-01(4.504E-02)
3.9 -- 4.0	6.408E-01(6.642E-02)	3.719E-01(4.870E-02)	3.438E-01(4.270E-02)
4.0 -- 4.1	5.504E-01(6.362E-02)	4.101E-01(5.171E-02)	3.838E-01(4.514E-02)
4.1 -- 4.2	5.467E-01(6.326E-02)	3.104E-01(4.434E-02)	3.589E-01(4.412E-02)
4.2 -- 4.3	5.199E-01(6.291E-02)	3.671E-01(4.927E-02)	2.374E-01(3.545E-02)
4.3 -- 4.4	3.970E-01(5.238E-02)	3.371E-01(4.616E-02)	3.002E-01(3.999E-02)
4.4 -- 4.5	4.214E-01(5.420E-02)	3.756E-01(4.993E-02)	2.783E-01(3.871E-02)
4.5 -- 4.6	3.137E-01(4.576E-02)	2.146E-01(3.697E-02)	2.727E-01(3.850E-02)
4.6 -- 4.7	3.439E-01(4.929E-02)	2.936E-01(4.485E-02)	2.359E-01(3.602E-02)
4.7 -- 4.8	3.558E-01(4.966E-02)	1.916E-01(3.504E-02)	6.620E-01(6.172E-02)
4.8 -- 4.9	3.193E-01(4.843E-02)	4.407E-01(5.525E-02)	1.084E+01(2.568E-01)
4.9 -- 5.0	3.762E-01(5.230E-02)	9.543E+00(2.695E-01)	1.705E+01(3.101E-01)
5.0 -- 5.1	3.989E+00(1.797E-01)	2.050E+01(3.859E-01)	7.797E+00(2.017E-01)
5.1 -- 5.2	2.245E+01(4.267E-01)	7.382E+00(2.208E-01)	6.541E+00(1.820E-01)
5.2 -- 5.3	1.041E+01(2.780E-01)	6.172E+00(1.960E-01)	9.619E-01(6.923E-02)
5.3 -- 5.4	6.864E+00(2.166E-01)	1.342E+00(9.061E-02)	5.305E-01(5.390E-02)
5.4 -- 5.5	2.476E+00(1.274E-01)	4.551E-01(5.433E-02)	3.067E-01(4.027E-02)
5.5 -- 5.6	5.634E-01(6.223E-02)	3.531E-01(4.761E-02)	2.617E-01(3.717E-02)
5.6 -- 5.7	4.383E-01(5.611E-02)	3.235E-01(4.598E-02)	1.975E+00(1.042E-01)
5.7 -- 5.8	3.110E-01(4.678E-02)	8.928E-01(7.950E-02)	2.160E+01(3.382E-01)
5.8 -- 5.9	4.440E-01(5.691E-02)	1.610E+01(3.289E-01)	2.530E+01(3.643E-01)
5.9 -- 6.0	5.436E+00(2.025E-01)	2.869E+01(4.347E-01)	4.837E+00(1.594E-01)
6.0 -- 6.1	3.045E+01(4.653E-01)	6.235E+00(1.992E-01)	8.888E-01(6.790E-02)
6.1 -- 6.2	1.521E+01(3.254E-01)	1.048E+00(8.291E-02)	7.786E-01(6.375E-02)
6.2 -- 6.3	2.106E+00(1.190E-01)	5.306E-01(5.848E-02)	3.910E-01(4.583E-02)
6.3 -- 6.4	8.928E-01(7.763E-02)	3.912E-01(4.933E-02)	2.761E-01(3.862E-02)
6.4 -- 6.5	4.933E-01(5.891E-02)	3.009E-01(4.404E-02)	2.514E-01(3.749E-02)
6.5 -- 6.6	3.576E-01(5.044E-02)	2.572E-01(4.016E-02)	2.418E-01(3.585E-02)
6.6 -- 6.7	2.625E-01(4.203E-02)	2.253E-01(3.866E-02)	2.810E-01(3.884E-02)
6.7 -- 6.8	1.952E-01(3.597E-02)	2.646E-01(4.003E-02)	1.642E-01(2.950E-02)
6.8 -- 6.9	2.185E-01(3.765E-02)	1.968E-01(3.498E-02)	1.389E-01(2.673E-02)
6.9 -- 7.0	2.251E-01(4.005E-02)	1.247E-01(2.846E-02)	1.723E-01(2.950E-02)
7.0 -- 7.1	2.503E-01(4.281E-02)	1.736E-01(3.334E-02)	6.773E-02(1.899E-02)
7.1 -- 7.2	2.156E-01(3.941E-02)	1.229E-01(2.596E-02)	1.488E-01(2.935E-02)
7.2 -- 7.3	1.830E-01(3.425E-02)	1.312E-01(2.975E-02)	1.251E-01(2.570E-02)
7.3 -- 7.4	1.507E-01(3.122E-02)	5.245E-02(1.820E-02)	1.077E-01(2.341E-02)
7.4 -- 7.5	1.362E-01(2.998E-02)	6.995E-02(2.126E-02)	9.277E-02(2.250E-02)
7.5 -- 7.6	1.120E-01(2.727E-02)	1.084E-01(2.697E-02)	1.136E-01(2.434E-02)
7.6 -- 7.7	1.234E-01(2.835E-02)	1.232E-01(2.826E-02)	1.215E-01(2.521E-02)
7.7 -- 7.8	1.029E-01(2.780E-02)	9.111E-02(2.282E-02)	9.078E-02(2.255E-02)
7.8 -- 7.9	1.174E-01(2.740E-02)	5.061E-02(1.725E-02)	9.754E-02(2.323E-02)
7.9 -- 8.0	8.370E-02(2.263E-02)	5.928E-02(1.825E-02)	1.093E-01(2.492E-02)

<< 160(p,p'x) Ep = 14 MeV >> *** DDX (error) in [mb/MeV*sr] ***

Ep' (MeV)	120 deg.	130 deg.	140 deg.
8.0 -- 8.1	5.354E-02 (1.836E-02)	2.588E-02 (1.215E-02)	5.300E-02 (1.700E-02)
8.1 -- 8.2	7.277E-02 (2.159E-02)	5.614E-02 (1.717E-02)	5.435E-02 (1.677E-02)
8.2 -- 8.3	7.829E-02 (2.226E-02)	5.606E-02 (1.714E-02)	6.910E-02 (1.988E-02)
8.3 -- 8.4	8.759E-02 (2.397E-02)	8.042E-02 (2.208E-02)	6.283E-02 (1.892E-02)
8.4 -- 8.5	5.897E-02 (2.022E-02)	4.866E-02 (1.806E-02)	7.333E-02 (2.041E-02)
8.5 -- 8.6	5.909E-02 (1.892E-02)	5.907E-02 (1.833E-02)	8.291E-02 (2.094E-02)
8.6 -- 8.7	1.032E-01 (2.684E-02)	2.965E-02 (1.367E-02)	4.650E-02 (1.568E-02)
8.7 -- 8.8	1.178E-01 (2.869E-02)	5.218E-02 (1.813E-02)	6.265E-02 (1.833E-02)
8.8 -- 8.9	8.432E-02 (2.414E-02)	6.853E-02 (2.112E-02)	5.407E-02 (1.775E-02)
8.9 -- 9.0	5.667E-02 (1.881E-02)	1.026E-01 (2.490E-02)	4.457E-02 (1.518E-02)
9.0 -- 9.1	6.627E-02 (2.010E-02)	7.738E-02 (2.257E-02)	5.693E-02 (1.741E-02)
9.1 -- 9.2	6.988E-02 (2.082E-02)	5.161E-02 (1.790E-02)	8.101E-02 (2.078E-02)
9.2 -- 9.3	8.404E-02 (2.390E-02)	1.126E-01 (2.661E-02)	7.796E-02 (2.051E-02)
9.3 -- 9.4	1.048E-01 (2.652E-02)	5.205E-02 (1.663E-02)	1.327E-01 (2.740E-02)
9.4 -- 9.5	1.106E-01 (2.713E-02)	7.442E-02 (2.013E-02)	8.015E-02 (2.115E-02)
9.5 -- 9.6	5.090E-02 (1.986E-02)	1.173E-01 (2.666E-02)	5.702E-02 (1.760E-02)
9.6 -- 9.7	1.375E-01 (2.870E-02)	8.355E-02 (2.233E-02)	4.399E-02 (1.489E-02)
9.7 -- 9.8	1.391E-01 (3.001E-02)	6.182E-02 (1.981E-02)	8.906E-02 (2.223E-02)
9.8 -- 9.9	9.466E-02 (2.284E-02)	9.740E-02 (2.383E-02)	7.392E-02 (2.024E-02)
9.9 -- 10.0	8.154E-02 (2.440E-02)	4.673E-02 (1.691E-02)	4.928E-02 (1.634E-02)
10.0 -- 10.1	9.943E-02 (2.692E-02)	1.038E-01 (2.458E-02)	6.524E-02 (1.912E-02)
10.1 -- 10.2	1.090E-01 (2.711E-02)	5.848E-02 (1.797E-02)	1.021E-01 (2.376E-02)
10.2 -- 10.3	1.136E-01 (2.624E-02)	6.810E-02 (2.075E-02)	7.482E-02 (2.072E-02)
10.3 -- 10.4	1.265E-01 (2.969E-02)	7.784E-02 (2.158E-02)	1.243E-01 (2.557E-02)
10.4 -- 10.5	3.909E-02 (1.433E-02)	7.658E-02 (2.091E-02)	2.095E-01 (3.329E-02)
10.5 -- 10.6	8.022E-02 (2.240E-02)	1.512E-01 (3.076E-02)	1.517E-01 (2.823E-02)
10.6 -- 10.7	1.569E-01 (3.210E-02)	2.202E-01 (3.791E-02)	1.721E-01 (2.988E-02)
10.7 -- 10.8	2.056E-01 (3.603E-02)	1.764E-01 (3.206E-02)	2.052E-01 (3.376E-02)
10.8 -- 10.9	2.533E-01 (4.084E-02)	2.912E-01 (4.369E-02)	2.325E-01 (3.581E-02)
10.9 -- 11.0	3.230E-01 (4.577E-02)	1.429E-01 (2.972E-02)	1.825E-01 (3.183E-02)
11.0 -- 11.1	3.286E-01 (4.652E-02)	2.889E-01 (4.201E-02)	1.605E+00 (9.685E-02)
11.1 -- 11.2	3.230E-01 (4.446E-02)	3.139E-01 (4.386E-02)	4.331E+01 (5.115E-01)
11.2 -- 11.3	2.413E-01 (4.008E-02)	5.476E+00 (1.907E-01)	9.369E+01 (7.134E-01)
11.3 -- 11.4	3.575E-01 (4.854E-02)	7.018E+01 (7.176E-01)	1.625E+01 (2.915E-01)
11.4 -- 11.5	3.575E+00 (1.580E-01)	7.035E+01 (8.071E-01)	2.783E+00 (1.221E-01)
11.5 -- 11.6	6.937E+01 (7.537E-01)	7.752E+00 (2.198E-01)	1.479E+00 (8.831E-02)
11.6 -- 11.7	9.638E+01 (1.056E+00)	2.000E+00 (1.104E-01)	9.263E-01 (7.101E-02)
11.7 -- 11.8	1.273E+01 (2.996E-01)	1.058E+00 (8.037E-02)	6.369E-01 (5.786E-02)
11.8 -- 11.9	2.728E+00 (1.316E-01)	7.005E-01 (6.486E-02)	5.134E-01 (5.214E-02)
11.9 -- 12.0	1.570E+00 (1.000E-01)	5.076E-01 (5.571E-02)	3.382E-01 (4.213E-02)
12.0 -- 12.1	9.022E-01 (7.570E-02)	3.501E-01 (4.518E-02)	3.001E-01 (4.090E-02)
12.1 -- 12.2	7.147E-01 (6.756E-02)	3.338E-01 (4.593E-02)	2.769E-01 (3.979E-02)
12.2 -- 12.3	5.324E-01 (5.904E-02)	2.242E-01 (3.644E-02)	1.520E-01 (2.844E-02)
12.3 -- 12.4	4.994E-01 (5.679E-02)	2.013E-01 (3.412E-02)	1.534E-01 (2.923E-02)
12.4 -- 12.5	3.929E-01 (5.001E-02)	1.571E-01 (3.047E-02)	1.215E-01 (2.503E-02)
12.5 -- 12.6	3.740E-01 (5.030E-02)	1.742E-01 (3.279E-02)	1.218E-01 (2.577E-02)
12.6 -- 12.7	2.648E-01 (4.008E-02)	1.032E-01 (2.440E-02)	7.560E-02 (1.930E-02)
12.7 -- 12.8	2.113E-01 (3.672E-02)	1.034E-01 (2.480E-02)	6.165E-02 (1.806E-02)
12.8 -- 12.9	1.329E-01 (2.963E-02)	1.112E-01 (2.615E-02)	7.366E-02 (1.958E-02)
12.9 -- 13.0	1.269E-01 (2.777E-02)	7.087E-02 (2.005E-02)	4.354E-02 (1.538E-02)

<< 16O(p,p'x) Ep = 14 MeV >> *** DDX (error) in [mb/MeV*sr] ***

Ep' (MeV)	120 deg.	130 deg.	140 deg.
13.0 -- 13.1	1.590E-01(3.192E-02)	3.352E-02(1.471E-02)	3.811E-02(1.363E-02)
13.1 -- 13.2	8.717E-02(2.313E-02)	8.577E-02(2.245E-02)	3.430E-02(1.369E-02)
13.2 -- 13.3	7.905E-02(2.255E-02)	3.476E-02(1.401E-02)	2.470E-02(1.194E-02)
13.3 -- 13.4	5.038E-02(1.843E-02)	2.234E-02(1.036E-02)	1.061E-02(8.010E-03)
13.4 -- 13.5	5.272E-02(1.825E-02)	9.050E-02(2.347E-02)	1.898E-02(1.014E-02)
13.5 -- 13.6	3.994E-02(1.708E-02)	3.827E-02(1.540E-02)	1.287E-02(8.090E-03)
13.6 -- 13.7	5.590E-02(1.948E-02)	1.515E-02(8.530E-03)	2.468E-02(1.125E-02)
13.7 -- 13.8	7.170E-03(6.130E-03)	1.516E-02(8.530E-03)	1.222E-02(8.640E-03)
13.8 -- 13.9	1.837E-02(1.116E-02)	1.715E-02(1.093E-02)	1.050E-02(7.460E-03)
13.9 -- 14.0	2.568E-02(1.170E-02)	3.650E-03(5.360E-03)	6.110E-03(6.110E-03)
14.0 -- 14.1	1.721E-02(1.079E-02)	9.840E-03(7.870E-03)	0.000E+00(0.000E+00)
14.1 -- 14.2	0.000E+00(0.000E+00)	1.015E-02(7.630E-03)	6.110E-03(6.110E-03)
14.2 -- 14.3	1.104E-02(7.610E-03)	3.050E-03(3.820E-03)	0.000E+00(0.000E+00)
14.3 -- 14.4	***** (*****)	***** (*****)	***** (*****)
14.4 -- 14.5	***** (*****)	***** (*****)	***** (*****)
14.5 -- 14.6	***** (*****)	***** (*****)	***** (*****)
14.6 -- 14.7	***** (*****)	***** (*****)	***** (*****)
14.7 -- 14.8	***** (*****)	***** (*****)	***** (*****)
14.8 -- 14.9	***** (*****)	***** (*****)	***** (*****)
14.9 -- 15.0	***** (*****)	***** (*****)	***** (*****)

<< 160(p,p'x) Ep = 14 MeV >> *** DDX (error) in [mb/MeV*sr] ***

Ep' (MeV)	150 deg.
3.0 -- 3.1	8.337E-01(5.926E-02)
3.1 -- 3.2	2.955E+00(1.162E-01)
3.2 -- 3.3	1.096E+01(2.202E-01)
3.3 -- 3.4	4.523E+00(1.375E-01)
3.4 -- 3.5	8.969E-01(6.210E-02)
3.5 -- 3.6	6.617E-01(5.311E-02)
3.6 -- 3.7	5.463E-01(4.848E-02)
3.7 -- 3.8	5.647E-01(4.982E-02)
3.8 -- 3.9	4.483E-01(4.395E-02)
3.9 -- 4.0	4.494E-01(4.508E-02)
4.0 -- 4.1	4.130E-01(4.256E-02)
4.1 -- 4.2	2.861E-01(3.502E-02)
4.2 -- 4.3	3.463E-01(3.870E-02)
4.3 -- 4.4	3.205E-01(3.782E-02)
4.4 -- 4.5	3.533E-01(3.891E-02)
4.5 -- 4.6	2.638E-01(3.336E-02)
4.6 -- 4.7	8.583E-01(6.375E-02)
4.7 -- 4.8	1.179E+01(2.426E-01)
4.8 -- 4.9	1.491E+01(2.604E-01)
4.9 -- 5.0	8.407E+00(1.881E-01)
5.0 -- 5.1	6.121E+00(1.588E-01)
5.1 -- 5.2	1.117E+00(6.788E-02)
5.2 -- 5.3	6.080E-01(5.104E-02)
5.3 -- 5.4	5.153E-01(4.789E-02)
5.4 -- 5.5	4.190E-01(4.267E-02)
5.5 -- 5.6	3.151E+00(1.199E-01)
5.6 -- 5.7	2.501E+01(3.277E-01)
5.7 -- 5.8	2.166E+01(3.036E-01)
5.8 -- 5.9	3.875E+00(1.294E-01)
5.9 -- 6.0	1.256E+00(7.349E-02)
6.0 -- 6.1	7.384E-01(5.676E-02)
6.1 -- 6.2	5.371E-01(4.786E-02)
6.2 -- 6.3	3.137E-01(3.674E-02)
6.3 -- 6.4	3.727E-01(4.020E-02)
6.4 -- 6.5	3.185E-01(3.666E-02)
6.5 -- 6.6	3.124E-01(3.724E-02)
6.6 -- 6.7	2.789E-01(3.533E-02)
6.7 -- 6.8	2.132E-01(3.121E-02)
6.8 -- 6.9	2.133E-01(3.075E-02)
6.9 -- 7.0	9.957E-02(2.134E-02)
7.0 -- 7.1	1.341E-01(2.414E-02)
7.1 -- 7.2	1.370E-01(2.513E-02)
7.2 -- 7.3	1.223E-01(2.330E-02)
7.3 -- 7.4	1.054E-01(2.199E-02)
7.4 -- 7.5	1.167E-01(2.340E-02)
7.5 -- 7.6	1.236E-01(2.385E-02)
7.6 -- 7.7	1.007E-01(2.141E-02)
7.7 -- 7.8	5.126E-02(1.527E-02)
7.8 -- 7.9	7.282E-02(1.809E-02)
7.9 -- 8.0	8.750E-02(2.000E-02)

<< 16O(p,p'x) Ep = 14 MeV >> *** DDX (error) in [mb/MeV*sr] ***

Ep' (MeV)	150 deg.
8.0 -- 8.1	5.276E-02(1.613E-02)
8.1 -- 8.2	1.029E-01(2.178E-02)
8.2 -- 8.3	1.093E-01(2.245E-02)
8.3 -- 8.4	6.235E-02(1.675E-02)
8.4 -- 8.5	8.003E-02(1.925E-02)
8.5 -- 8.6	9.882E-02(2.178E-02)
8.6 -- 8.7	7.089E-02(1.820E-02)
8.7 -- 8.8	6.301E-02(1.646E-02)
8.8 -- 8.9	6.797E-02(1.781E-02)
8.9 -- 9.0	4.699E-02(1.492E-02)
9.0 -- 9.1	9.095E-02(2.103E-02)
9.1 -- 9.2	1.829E-01(2.960E-02)
9.2 -- 9.3	1.140E-01(2.327E-02)
9.3 -- 9.4	7.275E-02(1.825E-02)
9.4 -- 9.5	7.626E-02(1.904E-02)
9.5 -- 9.6	7.682E-02(1.927E-02)
9.6 -- 9.7	6.101E-02(1.690E-02)
9.7 -- 9.8	7.276E-02(1.828E-02)
9.8 -- 9.9	7.618E-02(1.919E-02)
9.9 -- 10.0	6.468E-02(1.750E-02)
10.0 -- 10.1	5.645E-02(1.651E-02)
10.1 -- 10.2	1.228E-01(2.368E-02)
10.2 -- 10.3	1.720E-01(2.801E-02)
10.3 -- 10.4	2.049E-01(3.111E-02)
10.4 -- 10.5	2.061E-01(3.154E-02)
10.5 -- 10.6	2.619E-01(3.516E-02)
10.6 -- 10.7	3.271E-01(3.991E-02)
10.7 -- 10.8	3.059E-01(3.840E-02)
10.8 -- 10.9	4.633E-01(4.723E-02)
10.9 -- 11.0	1.815E+01(3.326E-01)
11.0 -- 11.1	1.095E+02(1.065E+00)
11.1 -- 11.2	4.656E+01(5.302E-01)
11.2 -- 11.3	5.365E+00(1.606E-01)
11.3 -- 11.4	2.782E+00(1.162E-01)
11.4 -- 11.5	1.653E+00(8.806E-02)
11.5 -- 11.6	1.206E+00(7.677E-02)
11.6 -- 11.7	9.097E-01(6.611E-02)
11.7 -- 11.8	5.177E-01(4.944E-02)
11.8 -- 11.9	4.814E-01(4.790E-02)
11.9 -- 12.0	4.597E-01(4.667E-02)
12.0 -- 12.1	3.060E-01(3.784E-02)
12.1 -- 12.2	2.354E-01(3.349E-02)
12.2 -- 12.3	2.304E-01(3.266E-02)
12.3 -- 12.4	1.695E-01(2.829E-02)
12.4 -- 12.5	1.206E-01(2.336E-02)
12.5 -- 12.6	8.399E-02(2.010E-02)
12.6 -- 12.7	6.861E-02(1.796E-02)
12.7 -- 12.8	9.428E-02(2.134E-02)
12.8 -- 12.9	5.390E-02(1.593E-02)
12.9 -- 13.0	6.332E-02(1.750E-02)

<< 160(p,p'x) Ep = 14 MeV >> *** DDX (error) in [mb/MeV*sr] ***

Ep' (MeV)	150 deg.
13.0 -- 13.1	2.858E-02 (1.182E-02)
13.1 -- 13.2	4.305E-02 (1.434E-02)
13.2 -- 13.3	3.363E-02 (1.295E-02)
13.3 -- 13.4	4.334E-02 (1.428E-02)
13.4 -- 13.5	3.060E-02 (1.189E-02)
13.5 -- 13.6	8.560E-03 (6.460E-03)
13.6 -- 13.7	1.861E-02 (9.050E-03)
13.7 -- 13.8	2.189E-02 (1.009E-02)
13.8 -- 13.9	2.523E-02 (1.101E-02)
13.9 -- 14.0	7.650E-03 (6.180E-03)
14.0 -- 14.1	7.650E-03 (6.180E-03)
14.1 -- 14.2	1.193E-02 (7.710E-03)
14.2 -- 14.3	4.990E-03 (4.990E-03)
14.3 -- 14.4	***** (*****)
14.4 -- 14.5	***** (*****)
14.5 -- 14.6	***** (*****)
14.6 -- 14.7	***** (*****)
14.7 -- 14.8	***** (*****)
14.8 -- 14.9	***** (*****)
14.9 -- 15.0	***** (*****)

Appendix 2 Double differential cross sections of the $^{16}\text{O}(p,p'x)$ reaction at 16 MeV.

<< $^{16}\text{O}(p,p'x)$ $E_p = 16$ MeV >> *** DDX (error) in [mb/MeV*sr] ***

$E_{p'}$ (MeV)	30 deg.	40 deg.	50 deg.
3.0 -- 3.1	7.048E-01 (6.562E-02)	7.988E-01 (6.687E-02)	8.770E-01 (7.754E-02)
3.1 -- 3.2	1.461E+00 (9.449E-02)	9.478E-01 (7.118E-02)	1.446E+00 (9.816E-02)
3.2 -- 3.3	3.022E+00 (1.349E-01)	2.068E+00 (1.068E-01)	3.082E+00 (1.402E-01)
3.3 -- 3.4	4.221E+00 (1.604E-01)	4.705E+00 (1.606E-01)	2.296E+00 (1.209E-01)
3.4 -- 3.5	8.524E+00 (2.271E-01)	3.941E+00 (1.454E-01)	1.705E+00 (1.051E-01)
3.5 -- 3.6	6.666E+00 (1.995E-01)	2.194E+00 (1.087E-01)	1.828E+00 (1.101E-01)
3.6 -- 3.7	4.236E+00 (1.588E-01)	2.152E+00 (1.079E-01)	2.837E+00 (1.370E-01)
3.7 -- 3.8	4.208E+00 (1.592E-01)	2.539E+00 (1.180E-01)	5.428E+00 (1.919E-01)
3.8 -- 3.9	4.703E+00 (1.675E-01)	4.950E+00 (1.657E-01)	6.861E+00 (2.139E-01)
3.9 -- 4.0	7.538E+00 (2.136E-01)	8.122E+00 (2.109E-01)	3.664E+00 (1.567E-01)
4.0 -- 4.1	1.195E+01 (2.677E-01)	5.810E+00 (1.776E-01)	2.370E+00 (1.245E-01)
4.1 -- 4.2	8.561E+00 (2.258E-01)	3.508E+00 (1.382E-01)	5.616E+00 (1.990E-01)
4.2 -- 4.3	5.246E+00 (1.762E-01)	3.354E+00 (1.364E-01)	1.933E+01 (3.628E-01)
4.3 -- 4.4	5.351E+00 (1.787E-01)	1.403E+01 (2.855E-01)	1.242E+01 (2.862E-01)
4.4 -- 4.5	1.432E+01 (2.990E-01)	1.637E+01 (3.012E-01)	4.809E+00 (1.800E-01)
4.5 -- 4.6	1.857E+01 (3.356E-01)	6.647E+00 (1.941E-01)	2.123E+00 (1.184E-01)
4.6 -- 4.7	7.567E+00 (2.139E-01)	3.028E+00 (1.289E-01)	1.481E+00 (9.775E-02)
4.7 -- 4.8	4.654E+00 (1.675E-01)	2.029E+00 (1.046E-01)	1.473E+00 (9.766E-02)
4.8 -- 4.9	4.180E+00 (1.584E-01)	1.865E+00 (1.001E-01)	1.509E+00 (1.001E-01)
4.9 -- 5.0	4.183E+00 (1.586E-01)	1.963E+00 (1.032E-01)	2.742E+00 (1.354E-01)
5.0 -- 5.1	3.948E+00 (1.530E-01)	2.467E+00 (1.172E-01)	3.597E+00 (1.520E-01)
5.1 -- 5.2	4.532E+00 (1.646E-01)	4.167E+00 (1.503E-01)	1.757E+00 (1.056E-01)
5.2 -- 5.3	6.625E+00 (1.994E-01)	3.333E+00 (1.335E-01)	1.489E+00 (9.858E-02)
5.3 -- 5.4	6.153E+00 (1.914E-01)	1.889E+00 (1.006E-01)	1.472E+00 (9.840E-02)
5.4 -- 5.5	4.293E+00 (1.599E-01)	1.852E+00 (1.002E-01)	4.438E+00 (1.749E-01)
5.5 -- 5.6	3.539E+00 (1.451E-01)	2.419E+00 (1.156E-01)	1.273E+01 (2.907E-01)
5.6 -- 5.7	4.363E+00 (1.610E-01)	1.062E+01 (2.451E-01)	5.093E+00 (1.807E-01)
5.7 -- 5.8	1.165E+01 (2.684E-01)	1.194E+01 (2.553E-01)	1.820E+00 (1.079E-01)
5.8 -- 5.9	1.653E+01 (3.157E-01)	3.572E+00 (1.381E-01)	1.450E+00 (9.561E-02)
5.9 -- 6.0	6.805E+00 (2.007E-01)	2.394E+00 (1.131E-01)	1.062E+00 (8.202E-02)
6.0 -- 6.1	4.859E+00 (1.702E-01)	1.874E+00 (1.010E-01)	8.937E-01 (7.651E-02)
6.1 -- 6.2	3.901E+00 (1.513E-01)	1.452E+00 (8.772E-02)	8.745E-01 (7.421E-02)
6.2 -- 6.3	3.731E+00 (1.488E-01)	1.271E+00 (8.191E-02)	5.961E-01 (6.080E-02)
6.3 -- 6.4	3.337E+00 (1.417E-01)	1.205E+00 (8.048E-02)	7.186E-01 (6.978E-02)
6.4 -- 6.5	3.273E+00 (1.411E-01)	1.145E+00 (7.879E-02)	5.599E+00 (1.983E-01)
6.5 -- 6.6	3.094E+00 (1.357E-01)	1.690E+00 (9.744E-02)	1.530E+01 (3.187E-01)
6.6 -- 6.7	3.457E+00 (1.448E-01)	1.060E+01 (2.459E-01)	4.526E+00 (1.698E-01)
6.7 -- 6.8	9.850E+00 (2.488E-01)	1.279E+01 (2.645E-01)	1.103E+00 (8.364E-02)
6.8 -- 6.9	1.865E+01 (3.365E-01)	2.729E+00 (1.205E-01)	6.483E-01 (6.538E-02)
6.9 -- 7.0	6.465E+00 (1.962E-01)	1.155E+00 (7.978E-02)	4.815E-01 (5.590E-02)
7.0 -- 7.1	3.055E+00 (1.355E-01)	9.105E-01 (6.982E-02)	5.613E-01 (6.228E-02)
7.1 -- 7.2	2.768E+00 (1.285E-01)	9.611E-01 (7.152E-02)	3.189E-01 (4.437E-02)
7.2 -- 7.3	2.533E+00 (1.227E-01)	9.200E-01 (7.122E-02)	3.032E-01 (4.440E-02)
7.3 -- 7.4	2.597E+00 (1.251E-01)	7.868E-01 (6.434E-02)	4.065E-01 (5.153E-02)
7.4 -- 7.5	2.646E+00 (1.256E-01)	8.310E-01 (6.661E-02)	3.622E-01 (4.753E-02)
7.5 -- 7.6	2.492E+00 (1.222E-01)	8.998E-01 (6.959E-02)	3.495E-01 (4.751E-02)
7.6 -- 7.7	2.600E+00 (1.247E-01)	7.239E-01 (6.187E-02)	4.168E-01 (5.223E-02)
7.7 -- 7.8	2.580E+00 (1.236E-01)	7.639E-01 (6.353E-02)	2.602E-01 (4.023E-02)
7.8 -- 7.9	2.464E+00 (1.210E-01)	7.155E-01 (6.159E-02)	3.527E-01 (4.819E-02)
7.9 -- 8.0	2.541E+00 (1.233E-01)	6.640E-01 (5.945E-02)	3.144E-01 (4.484E-02)

<< 16O(p,p'x) Ep = 16 MeV >> *** DDX (error) in [mb/MeV*sr] ***

Ep' (MeV)	30 deg.	40 deg.	50 deg.
8.0 -- 8.1	2.435E+00(1.200E-01)	8.078E-01(6.680E-02)	3.234E-01(4.515E-02)
8.1 -- 8.2	2.461E+00(1.210E-01)	7.188E-01(6.245E-02)	9.139E-01(7.817E-02)
8.2 -- 8.3	2.432E+00(1.199E-01)	6.675E-01(5.998E-02)	1.176E+01(2.771E-01)
8.3 -- 8.4	2.272E+00(1.164E-01)	2.156E+00(1.100E-01)	1.399E+01(3.050E-01)
8.4 -- 8.5	2.644E+00(1.261E-01)	1.453E+01(2.843E-01)	9.326E+00(2.481E-01)
8.5 -- 8.6	1.096E+01(2.650E-01)	1.350E+01(2.726E-01)	8.731E+00(2.373E-01)
8.6 -- 8.7	2.103E+01(3.590E-01)	1.290E+01(2.665E-01)	1.615E+00(1.001E-01)
8.7 -- 8.8	1.318E+01(2.833E-01)	1.041E+01(2.381E-01)	9.728E-01(7.974E-02)
8.8 -- 8.9	1.993E+01(3.467E-01)	2.219E+00(1.085E-01)	5.468E-01(5.945E-02)
8.9 -- 9.0	5.979E+00(1.875E-01)	1.197E+00(8.014E-02)	5.158E-01(5.771E-02)
9.0 -- 9.1	2.804E+00(1.284E-01)	1.030E+00(7.427E-02)	5.579E-01(6.025E-02)
9.1 -- 9.2	2.362E+00(1.177E-01)	9.302E-01(7.118E-02)	7.486E+00(2.332E-01)
9.2 -- 9.3	2.234E+00(1.146E-01)	1.105E+00(7.754E-02)	6.299E+01(6.505E-01)
9.3 -- 9.4	2.460E+00(1.205E-01)	9.229E+00(2.320E-01)	4.962E+01(6.072E-01)
9.4 -- 9.5	4.212E+00(1.620E-01)	6.832E+01(6.157E-01)	8.046E+00(2.271E-01)
9.5 -- 9.6	4.048E+01(5.050E-01)	5.051E+01(5.590E-01)	2.275E+00(1.199E-01)
9.6 -- 9.7	8.493E+01(7.348E-01)	7.613E+00(2.029E-01)	1.392E+00(9.370E-02)
9.7 -- 9.8	2.080E+01(3.619E-01)	2.727E+00(1.214E-01)	1.046E+00(8.185E-02)
9.8 -- 9.9	4.067E+00(1.548E-01)	1.754E+00(9.755E-02)	6.966E-01(6.699E-02)
9.9 -- 10.0	2.454E+00(1.213E-01)	1.345E+00(8.507E-02)	6.120E-01(6.278E-02)
10.0 -- 10.1	2.318E+00(1.166E-01)	1.194E+00(7.941E-02)	5.091E-01(5.799E-02)
10.1 -- 10.2	2.285E+00(1.165E-01)	8.635E-01(6.786E-02)	4.583E-01(5.546E-02)
10.2 -- 10.3	1.892E+00(1.058E-01)	7.639E-01(6.353E-02)	3.818E-01(4.972E-02)
10.3 -- 10.4	2.045E+00(1.117E-01)	7.518E-01(6.335E-02)	3.332E-01(4.623E-02)
10.4 -- 10.5	2.002E+00(1.090E-01)	7.721E-01(6.426E-02)	2.150E-01(3.791E-02)
10.5 -- 10.6	2.011E+00(1.090E-01)	7.520E-01(6.366E-02)	2.617E-01(4.033E-02)
10.6 -- 10.7	1.938E+00(1.074E-01)	6.437E-01(5.908E-02)	2.553E-01(4.079E-02)
10.7 -- 10.8	1.856E+00(1.053E-01)	5.838E-01(5.602E-02)	2.237E-01(3.813E-02)
10.8 -- 10.9	1.783E+00(1.018E-01)	5.622E-01(5.482E-02)	2.356E-01(3.884E-02)
10.9 -- 11.0	1.701E+00(1.017E-01)	5.722E-01(5.512E-02)	2.193E-01(3.767E-02)
11.0 -- 11.1	1.782E+00(1.020E-01)	4.915E-01(5.131E-02)	1.988E-01(3.577E-02)
11.1 -- 11.2	1.749E+00(1.016E-01)	3.932E-01(4.553E-02)	1.356E-01(2.788E-02)
11.2 -- 11.3	1.825E+00(1.036E-01)	4.614E-01(4.969E-02)	1.218E-01(2.692E-02)
11.3 -- 11.4	1.722E+00(1.008E-01)	5.250E-01(5.328E-02)	1.543E-01(3.141E-02)
11.4 -- 11.5	1.597E+00(9.668E-02)	3.588E-01(4.347E-02)	1.637E-01(3.353E-02)
11.5 -- 11.6	1.482E+00(9.315E-02)	3.342E-01(4.119E-02)	1.489E-01(2.946E-02)
11.6 -- 11.7	1.679E+00(9.958E-02)	4.898E-01(5.092E-02)	9.640E-02(2.459E-02)
11.7 -- 11.8	1.434E+00(9.101E-02)	3.810E-01(4.582E-02)	1.247E-01(2.737E-02)
11.8 -- 11.9	1.566E+00(9.610E-02)	3.276E-01(4.076E-02)	6.708E-02(2.083E-02)
11.9 -- 12.0	1.578E+00(9.618E-02)	3.029E-01(3.997E-02)	6.755E-02(1.944E-02)
12.0 -- 12.1	1.709E+00(1.009E-01)	3.927E-01(4.472E-02)	1.147E-01(2.731E-02)
12.1 -- 12.2	1.479E+00(9.384E-02)	3.319E-01(4.179E-02)	1.261E-01(2.867E-02)
12.2 -- 12.3	1.237E+00(8.609E-02)	2.851E-01(3.888E-02)	1.028E-01(2.615E-02)
12.3 -- 12.4	1.223E+00(8.443E-02)	3.723E-01(4.435E-02)	8.058E-02(2.258E-02)
12.4 -- 12.5	1.362E+00(8.948E-02)	3.776E-01(4.462E-02)	1.148E-01(2.678E-02)
12.5 -- 12.6	1.252E+00(8.535E-02)	3.530E-01(4.335E-02)	7.623E-02(2.111E-02)
12.6 -- 12.7	1.174E+00(8.360E-02)	2.593E-01(3.636E-02)	5.583E-02(1.900E-02)
12.7 -- 12.8	1.071E+00(7.954E-02)	2.555E-01(3.651E-02)	7.786E-02(2.175E-02)
12.8 -- 12.9	1.093E+00(8.083E-02)	3.586E-01(4.365E-02)	7.920E-02(2.236E-02)
12.9 -- 13.0	1.079E+00(8.060E-02)	3.119E-01(4.127E-02)	8.314E-02(2.428E-02)

<< 160(p,p'x) Ep = 16 MeV >> *** DDX (error) in [mb/MeV•sr] ***

Ep' (MeV)	30 deg.	40 deg.	50 deg.
13.0 -- 13.1	1.027E+00 (7.835E-02)	2.747E-01 (3.776E-02)	4.794E-02 (1.602E-02)
13.1 -- 13.2	1.103E+00 (7.990E-02)	3.285E-01 (4.153E-02)	9.773E-02 (2.479E-02)
13.2 -- 13.3	1.133E+00 (8.289E-02)	2.636E-01 (3.728E-02)	5.727E-02 (1.929E-02)
13.3 -- 13.4	1.122E+00 (8.094E-02)	2.590E-01 (3.737E-02)	9.640E-02 (2.605E-02)
13.4 -- 13.5	1.137E+00 (8.156E-02)	3.154E-01 (4.114E-02)	1.953E-01 (3.375E-02)
13.5 -- 13.6	9.821E-01 (7.545E-02)	3.837E-01 (4.574E-02)	1.569E-01 (3.190E-02)
13.6 -- 13.7	1.182E+00 (8.353E-02)	6.828E-01 (6.004E-02)	9.240E-02 (2.474E-02)
13.7 -- 13.8	1.705E+00 (1.006E-01)	6.691E-01 (5.953E-02)	7.947E-02 (2.241E-02)
13.8 -- 13.9	2.903E+00 (1.323E-01)	4.331E-01 (4.741E-02)	1.386E-01 (2.932E-02)
13.9 -- 14.0	2.302E+00 (1.170E-01)	3.631E-01 (4.417E-02)	6.496E-02 (2.081E-02)
14.0 -- 14.1	1.352E+00 (9.000E-02)	3.131E-01 (4.041E-02)	6.409E-02 (1.951E-02)
14.1 -- 14.2	1.191E+00 (8.403E-02)	3.794E-01 (4.583E-02)	6.157E-02 (1.860E-02)
14.2 -- 14.3	1.055E+00 (7.903E-02)	3.195E-01 (4.084E-02)	6.525E-02 (2.023E-02)
14.3 -- 14.4	1.243E+00 (8.588E-02)	4.052E-01 (4.639E-02)	1.105E-01 (2.648E-02)
14.4 -- 14.5	1.291E+00 (8.759E-02)	4.418E-01 (4.754E-02)	1.227E-01 (2.912E-02)
14.5 -- 14.6	1.243E+00 (8.552E-02)	3.462E-01 (4.251E-02)	1.433E-01 (2.859E-02)
14.6 -- 14.7	1.355E+00 (8.935E-02)	4.524E-01 (4.889E-02)	1.846E-01 (3.487E-02)
14.7 -- 14.8	1.386E+00 (9.106E-02)	4.728E-01 (4.980E-02)	1.995E-01 (3.539E-02)
14.8 -- 14.9	1.596E+00 (9.739E-02)	5.077E-01 (5.183E-02)	2.794E-01 (4.132E-02)
14.9 -- 15.0	1.830E+00 (1.041E-01)	7.948E-01 (6.426E-02)	1.763E-01 (3.209E-02)
15.0 -- 15.1	2.571E+00 (1.243E-01)	1.049E+00 (7.448E-02)	4.422E-01 (5.339E-02)
15.1 -- 15.2	3.614E+00 (1.482E-01)	1.228E+00 (8.080E-02)	5.645E+00 (1.995E-01)
15.2 -- 15.3	5.148E+00 (1.749E-01)	1.222E+00 (8.045E-02)	6.149E+01 (6.409E-01)
15.3 -- 15.4	4.947E+00 (1.714E-01)	3.563E+00 (1.409E-01)	6.388E+01 (7.789E-01)
15.4 -- 15.5	5.772E+00 (1.854E-01)	1.010E+02 (7.483E-01)	9.088E+00 (2.453E-01)
15.5 -- 15.6	3.771E+01 (4.953E-01)	3.909E+02 (2.229E+00)	2.361E+00 (1.212E-01)
15.6 -- 15.7	7.611E+02 (2.212E+00)	1.424E+02 (1.484E+00)	1.348E+00 (9.193E-02)
15.7 -- 15.8	1.647E+03 (6.494E+00)	1.978E+01 (3.474E-01)	1.146E+00 (8.529E-02)
15.8 -- 15.9	3.458E+02 (2.968E+00)	9.089E+00 (2.228E-01)	6.459E-01 (6.481E-02)
15.9 -- 16.0	4.180E+01 (5.302E-01)	5.522E+00 (1.721E-01)	4.446E-01 (5.290E-02)
16.0 -- 16.1	***** (*****)	***** (*****)	***** (*****)
16.1 -- 16.2	***** (*****)	***** (*****)	***** (*****)
16.2 -- 16.3	***** (*****)	***** (*****)	***** (*****)
16.3 -- 16.4	***** (*****)	***** (*****)	***** (*****)
16.4 -- 16.5	***** (*****)	***** (*****)	***** (*****)
16.5 -- 16.6	***** (*****)	***** (*****)	***** (*****)
16.6 -- 16.7	***** (*****)	***** (*****)	***** (*****)
16.7 -- 16.8	***** (*****)	***** (*****)	***** (*****)
16.8 -- 16.9	***** (*****)	***** (*****)	***** (*****)
16.9 -- 17.0	***** (*****)	***** (*****)	***** (*****)

<< 16O(p,p'x) Ep = 16 MeV >> *** DDX (error) in [mb/MeV*sr] ***

Ep' (MeV)	60 deg.	70 deg.	80 deg.
3.0 -- 3.1	8.378E-01(7.654E-02)	8.958E-01(8.569E-02)	6.675E-01(7.311E-02)
3.1 -- 3.2	1.099E+00(8.912E-02)	1.004E+00(8.995E-02)	1.143E+00(9.715E-02)
3.2 -- 3.3	1.585E+00(1.050E-01)	1.433E+00(1.079E-01)	3.330E+00(1.677E-01)
3.3 -- 3.4	1.680E+00(1.091E-01)	2.365E+00(1.402E-01)	7.336E+00(2.470E-01)
3.4 -- 3.5	1.887E+00(1.148E-01)	4.968E+00(2.038E-01)	5.682E+00(2.155E-01)
3.5 -- 3.6	3.372E+00(1.563E-01)	6.996E+00(2.420E-01)	3.073E+00(1.576E-01)
3.6 -- 3.7	6.417E+00(2.190E-01)	3.967E+00(1.802E-01)	3.656E+00(1.755E-01)
3.7 -- 3.8	5.353E+00(1.957E-01)	2.456E+00(1.406E-01)	1.340E+01(3.373E-01)
3.8 -- 3.9	2.684E+00(1.384E-01)	5.659E+00(2.196E-01)	1.110E+01(2.990E-01)
3.9 -- 4.0	2.967E+00(1.465E-01)	1.625E+01(3.672E-01)	4.819E+00(1.972E-01)
4.0 -- 4.1	1.227E+01(3.030E-01)	1.030E+01(2.883E-01)	2.056E+00(1.287E-01)
4.1 -- 4.2	1.732E+01(3.499E-01)	4.613E+00(1.933E-01)	1.531E+00(1.117E-01)
4.2 -- 4.3	7.199E+00(2.266E-01)	2.104E+00(1.293E-01)	1.540E+00(1.113E-01)
4.3 -- 4.4	3.085E+00(1.473E-01)	1.611E+00(1.133E-01)	1.854E+00(1.229E-01)
4.4 -- 4.5	1.727E+00(1.101E-01)	1.488E+00(1.095E-01)	4.636E+00(1.968E-01)
4.5 -- 4.6	1.396E+00(9.860E-02)	1.656E+00(1.161E-01)	5.217E+00(2.047E-01)
4.6 -- 4.7	1.371E+00(9.833E-02)	4.189E+00(1.840E-01)	1.938E+00(1.247E-01)
4.7 -- 4.8	1.974E+00(1.187E-01)	4.231E+00(1.835E-01)	1.363E+00(1.053E-01)
4.8 -- 4.9	4.097E+00(1.701E-01)	1.720E+00(1.163E-01)	1.472E+00(1.093E-01)
4.9 -- 5.0	2.522E+00(1.314E-01)	1.339E+00(1.046E-01)	5.506E+00(2.119E-01)
5.0 -- 5.1	1.220E+00(9.238E-02)	1.459E+00(1.084E-01)	6.813E+00(2.313E-01)
5.1 -- 5.2	1.010E+00(8.423E-02)	7.187E+00(2.421E-01)	2.214E+00(1.313E-01)
5.2 -- 5.3	2.470E+00(1.344E-01)	7.910E+00(2.489E-01)	1.628E+00(1.134E-01)
5.3 -- 5.4	1.050E+01(2.735E-01)	2.091E+00(1.270E-01)	1.193E+00(9.643E-02)
5.4 -- 5.5	6.805E+00(2.164E-01)	1.715E+00(1.161E-01)	1.022E+00(8.956E-02)
5.5 -- 5.6	1.856E+00(1.120E-01)	1.260E+00(9.821E-02)	8.374E-01(8.168E-02)
5.6 -- 5.7	1.546E+00(1.017E-01)	1.199E+00(9.748E-02)	6.953E-01(7.389E-02)
5.7 -- 5.8	1.068E+00(8.485E-02)	9.288E-01(8.388E-02)	5.834E-01(6.706E-02)
5.8 -- 5.9	7.544E-01(7.085E-02)	7.656E-01(7.685E-02)	6.084E+00(2.346E-01)
5.9 -- 6.0	7.630E-01(7.190E-02)	6.704E-01(7.307E-02)	2.415E+01(4.616E-01)
6.0 -- 6.1	6.657E-01(6.756E-02)	4.453E+00(1.971E-01)	9.577E+00(2.779E-01)
6.1 -- 6.2	6.703E-01(6.827E-02)	2.088E+01(4.212E-01)	1.384E+00(1.051E-01)
6.2 -- 6.3	4.921E+00(1.938E-01)	9.998E+00(2.823E-01)	8.322E-01(8.135E-02)
6.3 -- 6.4	1.856E+01(3.651E-01)	1.459E+00(1.067E-01)	6.817E-01(7.461E-02)
6.4 -- 6.5	6.697E+00(2.147E-01)	1.007E+00(9.032E-02)	4.933E-01(6.322E-02)
6.5 -- 6.6	1.297E+00(9.618E-02)	5.712E-01(6.798E-02)	6.107E-01(7.015E-02)
6.6 -- 6.7	8.292E-01(7.692E-02)	7.070E-01(7.664E-02)	4.983E-01(6.337E-02)
6.7 -- 6.8	5.559E-01(6.144E-02)	5.502E-01(6.718E-02)	4.145E-01(5.842E-02)
6.8 -- 6.9	4.678E-01(5.746E-02)	5.899E-01(6.728E-02)	6.026E-01(6.953E-02)
6.9 -- 7.0	4.906E-01(5.765E-02)	6.583E-01(7.400E-02)	5.294E-01(6.568E-02)
7.0 -- 7.1	3.383E-01(4.824E-02)	4.436E-01(5.987E-02)	4.024E-01(5.698E-02)
7.1 -- 7.2	4.713E-01(5.780E-02)	5.211E-01(6.432E-02)	4.173E-01(5.762E-02)
7.2 -- 7.3	4.172E-01(5.370E-02)	5.285E-01(6.603E-02)	2.799E-01(4.726E-02)
7.3 -- 7.4	4.406E-01(5.565E-02)	4.649E-01(5.974E-02)	5.179E-01(6.479E-02)
7.4 -- 7.5	5.055E-01(5.889E-02)	4.315E-01(5.852E-02)	4.963E-01(6.243E-02)
7.5 -- 7.6	2.916E-01(4.530E-02)	4.260E-01(5.982E-02)	2.927E+00(1.547E-01)
7.6 -- 7.7	2.777E-01(4.496E-02)	4.683E-01(6.110E-02)	1.037E+01(2.860E-01)
7.7 -- 7.8	4.600E-01(5.731E-02)	1.498E+00(1.103E-01)	6.626E+00(2.290E-01)
7.8 -- 7.9	3.625E-01(4.902E-02)	1.126E+01(2.982E-01)	9.603E+00(2.780E-01)
7.9 -- 8.0	1.436E+00(1.020E-01)	1.010E+01(2.817E-01)	3.277E+00(1.597E-01)

<< 160(p,p'x) Ep = 16 MeV >> *** DDX (error) in [mb/MeV*sr] ***

Ep' (MeV)	60 deg.	70 deg.	80 deg.
8.0 -- 8.1	1.186E+01(2.872E-01)	8.764E+00(2.657E-01)	9.029E-01(8.485E-02)
8.1 -- 8.2	1.237E+01(3.014E-01)	5.947E+00(2.144E-01)	5.889E-01(6.801E-02)
8.2 -- 8.3	8.643E+00(2.466E-01)	1.279E+00(9.786E-02)	4.716E-01(6.211E-02)
8.3 -- 8.4	6.574E+00(2.126E-01)	6.790E-01(7.281E-02)	5.595E-01(6.591E-02)
8.4 -- 8.5	1.268E+00(9.200E-02)	5.464E-01(6.559E-02)	2.798E+00(1.562E-01)
8.5 -- 8.6	7.223E-01(7.068E-02)	5.801E-01(6.768E-02)	2.969E+01(5.036E-01)
8.6 -- 8.7	6.030E-01(6.451E-02)	9.101E-01(8.738E-02)	3.195E+01(5.064E-01)
8.7 -- 8.8	5.526E-01(6.247E-02)	1.605E+01(3.724E-01)	5.449E+00(2.076E-01)
8.8 -- 8.9	6.339E-01(6.717E-02)	5.243E+01(6.491E-01)	1.393E+00(1.054E-01)
8.9 -- 9.0	1.202E+01(3.014E-01)	1.932E+01(3.969E-01)	8.941E-01(8.319E-02)
9.0 -- 9.1	6.243E+01(6.628E-01)	3.128E+00(1.547E-01)	6.835E-01(7.315E-02)
9.1 -- 9.2	3.288E+01(5.144E-01)	1.462E+00(1.064E-01)	6.091E-01(6.987E-02)
9.2 -- 9.3	5.358E+00(1.918E-01)	1.106E+00(9.317E-02)	4.879E-01(6.255E-02)
9.3 -- 9.4	1.815E+00(1.113E-01)	7.366E-01(7.554E-02)	4.012E-01(5.658E-02)
9.4 -- 9.5	1.124E+00(8.773E-02)	4.832E-01(6.188E-02)	4.185E-01(5.815E-02)
9.5 -- 9.6	8.288E-01(7.594E-02)	7.305E-01(7.679E-02)	3.479E-01(5.134E-02)
9.6 -- 9.7	5.958E-01(6.406E-02)	4.504E-01(5.939E-02)	3.713E-01(5.500E-02)
9.7 -- 9.8	5.576E-01(6.211E-02)	5.437E-01(6.528E-02)	4.129E-01(5.709E-02)
9.8 -- 9.9	5.117E-01(5.977E-02)	4.865E-01(6.333E-02)	3.645E-01(5.364E-02)
9.9 -- 10.0	5.053E-01(6.001E-02)	4.770E-01(6.162E-02)	2.296E-01(4.249E-02)
10.0 -- 10.1	3.885E-01(5.218E-02)	4.341E-01(5.707E-02)	3.016E-01(4.791E-02)
10.1 -- 10.2	4.258E-01(5.451E-02)	3.258E-01(5.092E-02)	2.818E-01(4.696E-02)
10.2 -- 10.3	4.134E-01(5.334E-02)	3.360E-01(5.237E-02)	2.778E-01(4.789E-02)
10.3 -- 10.4	3.245E-01(4.707E-02)	3.513E-01(5.348E-02)	4.879E-01(4.426E-02)
10.4 -- 10.5	2.934E-01(4.514E-02)	3.059E-01(4.892E-02)	2.085E-01(4.001E-02)
10.5 -- 10.6	2.535E-01(4.131E-02)	3.435E-01(5.232E-02)	2.224E-01(4.224E-02)
10.6 -- 10.7	2.857E-01(4.487E-02)	2.626E-01(4.545E-02)	2.189E-01(4.225E-02)
10.7 -- 10.8	1.698E-01(3.340E-02)	2.379E-01(4.334E-02)	2.032E-01(4.120E-02)
10.8 -- 10.9	2.665E-01(4.377E-02)	2.234E-01(4.242E-02)	1.961E-01(3.842E-02)
10.9 -- 11.0	1.953E-01(3.727E-02)	2.255E-01(4.210E-02)	1.718E-01(3.640E-02)
11.0 -- 11.1	1.770E-01(3.604E-02)	2.346E-01(4.272E-02)	1.578E-01(3.552E-02)
11.1 -- 11.2	2.018E-01(3.749E-02)	3.073E-01(4.915E-02)	1.433E-01(3.425E-02)
11.2 -- 11.3	2.049E-01(3.624E-02)	1.835E-01(3.840E-02)	2.449E-01(4.552E-02)
11.3 -- 11.4	2.076E-01(3.720E-02)	2.612E-01(4.459E-02)	1.828E-01(3.829E-02)
11.4 -- 11.5	1.542E-01(3.234E-02)	2.319E-01(4.287E-02)	1.857E-01(3.811E-02)
11.5 -- 11.6	1.781E-01(3.685E-02)	1.563E-01(3.546E-02)	2.112E-01(4.018E-02)
11.6 -- 11.7	1.468E-01(3.298E-02)	1.256E-01(3.142E-02)	2.107E-01(4.161E-02)
11.7 -- 11.8	1.628E-01(3.270E-02)	2.338E-01(4.379E-02)	1.862E-01(3.709E-02)
11.8 -- 11.9	1.381E-01(3.050E-02)	2.140E-01(4.135E-02)	2.261E-01(4.305E-02)
11.9 -- 12.0	1.706E-01(3.470E-02)	1.789E-01(3.669E-02)	1.847E-01(3.804E-02)
12.0 -- 12.1	1.549E-01(3.286E-02)	2.297E-01(4.312E-02)	1.587E-01(3.466E-02)
12.1 -- 12.2	1.465E-01(3.228E-02)	1.707E-01(3.670E-02)	2.085E-01(4.109E-02)
12.2 -- 12.3	1.377E-01(3.092E-02)	1.764E-01(3.690E-02)	1.997E-01(3.982E-02)
12.3 -- 12.4	1.021E-01(2.647E-02)	2.343E-01(4.407E-02)	2.565E-01(4.579E-02)
12.4 -- 12.5	1.322E-01(3.069E-02)	1.721E-01(3.606E-02)	4.204E-01(5.821E-02)
12.5 -- 12.6	7.540E-02(2.270E-02)	2.213E-01(4.195E-02)	4.946E-01(6.309E-02)
12.6 -- 12.7	1.401E-01(3.147E-02)	2.266E-01(4.325E-02)	4.646E-01(6.051E-02)
12.7 -- 12.8	1.028E-01(2.767E-02)	2.988E-01(4.858E-02)	2.369E-01(4.324E-02)
12.8 -- 12.9	1.166E-01(2.857E-02)	6.001E-01(6.965E-02)	2.691E-01(4.578E-02)
12.9 -- 13.0	1.590E-01(3.269E-02)	5.007E-01(6.148E-02)	2.418E-01(4.287E-02)

<< 160(p,p'x) Ep = 16 MeV >> *** DDX (error) in [mb/MeV*sr] ***

Ep' (MeV)	60 deg.	70 deg.	80 deg.
13.0 -- 13.1	1.785E-01(3.439E-02)	2.737E-01(4.588E-02)	2.668E-01(4.508E-02)
13.1 -- 13.2	4.234E-01(5.515E-02)	2.640E-01(4.556E-02)	2.487E-01(4.497E-02)
13.2 -- 13.3	2.679E-01(4.367E-02)	2.968E-01(4.863E-02)	3.120E-01(4.982E-02)
13.3 -- 13.4	1.541E-01(3.164E-02)	2.723E-01(4.643E-02)	3.015E-01(4.970E-02)
13.4 -- 13.5	1.557E-01(3.338E-02)	2.313E-01(4.395E-02)	2.587E-01(4.538E-02)
13.5 -- 13.6	9.758E-02(2.556E-02)	2.894E-01(4.847E-02)	3.534E-01(5.370E-02)
13.6 -- 13.7	1.316E-01(3.103E-02)	1.807E-01(3.796E-02)	3.519E-01(5.414E-02)
13.7 -- 13.8	1.068E-01(2.693E-02)	3.023E-01(4.840E-02)	5.523E-01(6.651E-02)
13.8 -- 13.9	1.605E-01(3.313E-02)	2.802E-01(4.691E-02)	8.452E-01(8.336E-02)
13.9 -- 14.0	1.140E-01(2.762E-02)	4.804E-01(6.304E-02)	1.076E+00(9.419E-02)
14.0 -- 14.1	1.626E-01(3.331E-02)	4.590E-01(6.101E-02)	9.221E-01(8.598E-02)
14.1 -- 14.2	1.473E-01(3.203E-02)	6.503E-01(7.208E-02)	9.338E-01(8.600E-02)
14.2 -- 14.3	2.527E-01(4.176E-02)	1.030E+00(9.118E-02)	6.187E+00(2.325E-01)
14.3 -- 14.4	3.782E-01(5.164E-02)	9.380E-01(8.552E-02)	1.318E+02(1.097E+00)
14.4 -- 14.5	5.647E-01(6.299E-02)	8.512E-01(8.328E-02)	3.028E+02(1.682E+00)
14.5 -- 14.6	6.406E-01(6.655E-02)	3.544E+00(1.738E-01)	7.468E+01(8.901E-01)
14.6 -- 14.7	1.166E-01(6.517E-02)	9.457E+01(9.498E-01)	1.151E+01(3.013E-01)
14.7 -- 14.8	6.371E-01(6.656E-02)	3.184E+02(1.659E+00)	5.502E+00(2.073E-01)
14.8 -- 14.9	5.831E+00(2.112E-01)	1.055E+02(1.109E+00)	3.479E+00(1.659E-01)
14.9 -- 15.0	1.039E+02(9.416E-01)	1.510E+01(3.460E-01)	2.564E+00(1.428E-01)
15.0 -- 15.1	1.808E+02(1.215E+00)	6.437E+00(2.250E-01)	1.809E+00(1.207E-01)
15.1 -- 15.2	3.275E+01(5.268E-01)	4.017E+00(1.774E-01)	1.334E+00(1.024E-01)
15.2 -- 15.3	6.368E+00(2.096E-01)	2.902E+00(1.516E-01)	1.041E+00(8.953E-02)
15.3 -- 15.4	3.314E+00(1.514E-01)	2.160E+00(1.296E-01)	8.431E-01(8.117E-02)
15.4 -- 15.5	2.148E+00(1.221E-01)	1.816E+00(1.202E-01)	7.547E-01(7.747E-02)
15.5 -- 15.6	1.816E+00(1.131E-01)	1.412E+00(1.043E-01)	6.570E-01(7.196E-02)
15.6 -- 15.7	1.236E+00(9.232E-02)	9.954E-01(8.792E-02)	5.973E-01(6.886E-02)
15.7 -- 15.8	8.058E-01(7.460E-02)	7.637E-01(7.657E-02)	5.348E-01(6.521E-02)
15.8 -- 15.9	7.363E-01(7.025E-02)	8.090E-01(7.907E-02)	4.871E-01(6.206E-02)
15.9 -- 16.0	5.521E-01(6.249E-02)	6.221E-01(7.053E-02)	2.237E-01(4.213E-02)
16.0 -- 16.1	***** (*****)	***** (*****)	***** (*****)
16.1 -- 16.2	***** (*****)	***** (*****)	***** (*****)
16.2 -- 16.3	***** (*****)	***** (*****)	***** (*****)
16.3 -- 16.4	***** (*****)	***** (*****)	***** (*****)
16.4 -- 16.5	***** (*****)	***** (*****)	***** (*****)
16.5 -- 16.6	***** (*****)	***** (*****)	***** (*****)
16.6 -- 16.7	***** (*****)	***** (*****)	***** (*****)
16.7 -- 16.8	***** (*****)	***** (*****)	***** (*****)
16.8 -- 16.9	***** (*****)	***** (*****)	***** (*****)
16.9 -- 17.0	***** (*****)	***** (*****)	***** (*****)

<< 16O(p,p')x Ep = 16 MeV >> *** DDX (error) in [mb/MeV*sr] ***

Ep' (MeV)	90 deg.	100 deg.	110 deg.
3.0 -- 3.1	1.019E+00(9.296E-02)	1.066E+00(8.147E-02)	9.586E-01(7.791E-02)
3.1 -- 3.2	2.867E+00(1.585E-01)	1.336E+00(9.118E-02)	1.844E+00(1.111E-01)
3.2 -- 3.3	4.057E+00(1.843E-01)	1.875E+00(1.074E-01)	8.283E+00(2.361E-01)
3.3 -- 3.4	3.050E+00(1.594E-01)	4.975E+00(1.810E-01)	6.971E+00(2.109E-01)
3.4 -- 3.5	2.553E+00(1.485E-01)	1.103E+01(2.650E-01)	2.741E+00(1.316E-01)
3.5 -- 3.6	9.388E+00(2.891E-01)	5.465E+00(1.831E-01)	1.737E+00(1.046E-01)
3.6 -- 3.7	1.162E+01(3.145E-01)	2.307E+00(1.179E-01)	1.284E+00(9.058E-02)
3.7 -- 3.8	4.844E+00(2.008E-01)	1.535E+00(9.675E-02)	1.303E+00(9.120E-02)
3.8 -- 3.9	2.013E+00(1.282E-01)	1.338E+00(9.116E-02)	2.373E+00(1.249E-01)
3.9 -- 4.0	1.518E+00(1.152E-01)	1.337E+00(9.166E-02)	5.395E+00(1.870E-01)
4.0 -- 4.1	1.433E+00(1.095E-01)	3.433E+00(1.490E-01)	3.940E+00(1.574E-01)
4.1 -- 4.2	1.785E+00(1.236E-01)	6.344E+00(1.980E-01)	1.646E+00(1.014E-01)
4.2 -- 4.3	4.639E+00(2.012E-01)	2.575E+00(1.240E-01)	1.102E+00(8.421E-02)
4.3 -- 4.4	5.815E+00(2.209E-01)	1.322E+00(9.061E-02)	2.042E+00(1.154E-01)
4.4 -- 4.5	2.303E+00(1.369E-01)	1.111E+00(8.220E-02)	4.532E+00(1.680E-01)
4.5 -- 4.6	1.161E+00(9.817E-02)	3.030E+00(1.372E-01)	2.208E+00(1.172E-01)
4.6 -- 4.7	1.370E+00(1.070E-01)	4.644E+00(1.666E-01)	1.639E+00(1.042E-01)
4.7 -- 4.8	4.183E+00(1.870E-01)	2.026E+00(1.106E-01)	1.409E+00(9.690E-02)
4.8 -- 4.9	5.353E+00(2.075E-01)	1.413E+00(9.286E-02)	1.144E+00(8.709E-02)
4.9 -- 5.0	1.700E+00(1.154E-01)	1.189E+00(8.584E-02)	8.371E-01(7.255E-02)
5.0 -- 5.1	1.395E+00(1.068E-01)	8.661E-01(7.308E-02)	5.615E-01(6.143E-02)
5.1 -- 5.2	1.306E+00(1.042E-01)	5.622E-01(5.991E-02)	6.579E-01(6.644E-02)
5.2 -- 5.3	1.032E+00(9.172E-02)	5.189E-01(5.707E-02)	5.482E+00(1.982E-01)
5.3 -- 5.4	8.484E-01(8.362E-02)	7.039E-01(6.765E-02)	1.920E+01(3.646E-01)
5.4 -- 5.5	6.406E-01(7.273E-02)	8.446E+00(2.410E-01)	6.950E+00(2.115E-01)
5.5 -- 5.6	8.308E-01(8.485E-02)	2.168E+01(3.803E-01)	1.398E+00(9.430E-02)
5.6 -- 5.7	8.790E+00(2.890E-01)	6.030E+00(1.937E-01)	6.503E-01(6.521E-02)
5.7 -- 5.8	2.297E+01(4.579E-01)	1.212E+00(8.832E-02)	5.464E-01(5.922E-02)
5.8 -- 5.9	7.095E+00(2.443E-01)	7.638E-01(7.036E-02)	4.330E-01(5.291E-02)
5.9 -- 6.0	1.555E+00(1.167E-01)	5.663E-01(5.992E-02)	3.776E-01(4.894E-02)
6.0 -- 6.1	7.748E-01(8.036E-02)	4.324E-01(5.219E-02)	3.697E-01(4.759E-02)
6.1 -- 6.2	6.284E-01(7.291E-02)	3.817E-01(4.892E-02)	3.119E-01(4.562E-02)
6.2 -- 6.3	4.515E-01(6.314E-02)	4.428E-01(5.348E-02)	2.586E-01(4.142E-02)
6.3 -- 6.4	4.294E-01(6.116E-02)	2.902E-01(4.293E-02)	2.376E-01(4.014E-02)
6.4 -- 6.5	3.648E-01(5.557E-02)	3.341E-01(4.585E-02)	1.899E-01(3.583E-02)
6.5 -- 6.6	4.772E-01(6.344E-02)	3.126E-01(4.473E-02)	1.858E-01(3.551E-02)
6.6 -- 6.7	3.280E-01(5.245E-02)	2.145E-01(3.678E-02)	1.575E-01(3.228E-02)
6.7 -- 6.8	4.593E-01(6.227E-02)	1.824E-01(3.390E-02)	1.583E-01(3.161E-02)
6.8 -- 6.9	3.247E-01(5.122E-02)	2.254E-01(3.744E-02)	1.762E+00(1.095E-01)
6.9 -- 7.0	3.637E-01(5.395E-02)	2.115E-01(3.523E-02)	7.982E+00(2.294E-01)
7.0 -- 7.1	3.922E-01(5.586E-02)	1.041E+00(8.225E-02)	5.613E+00(1.905E-01)
7.1 -- 7.2	3.874E-01(5.657E-02)	5.704E+00(1.903E-01)	7.847E+00(2.223E-01)
7.2 -- 7.3	6.319E-01(7.401E-02)	5.586E+00(1.859E-01)	3.231E+00(1.398E-01)
7.3 -- 7.4	4.798E+00(2.025E-01)	7.855E+00(2.188E-01)	7.418E-01(6.740E-02)
7.4 -- 7.5	6.897E+00(2.369E-01)	3.988E+00(1.533E-01)	4.936E-01(5.598E-02)
7.5 -- 7.6	7.172E+00(2.459E-01)	8.771E-01(7.150E-02)	3.731E-01(4.824E-02)
7.6 -- 7.7	6.435E+00(2.279E-01)	4.642E-01(5.316E-02)	3.304E-01(4.648E-02)
7.7 -- 7.8	1.373E+00(1.041E-01)	2.932E-01(4.214E-02)	2.944E+00(1.433E-01)
7.8 -- 7.9	6.579E-01(7.272E-02)	3.223E-01(4.433E-02)	1.872E+01(3.540E-01)
7.9 -- 8.0	5.174E-01(6.545E-02)	1.564E+00(1.029E-01)	1.870E+01(3.432E-01)

<< 160(p,p'x) Ep = 16 MeV >> *** DDX (error) in [mb/MeV*sr] ***

Ep' (MeV)	90 deg.	100 deg.	110 deg.
8.0 -- 8.1	4.796E-01(6.436E-02)	1.625E+01(3.298E-01)	5.186E+00(1.772E-01)
8.1 -- 8.2	7.745E-01(8.319E-02)	2.068E+01(3.567E-01)	1.290E+00(8.949E-02)
8.2 -- 8.3	9.703E+00(2.980E-01)	6.110E+00(1.903E-01)	7.608E-01(6.888E-02)
8.3 -- 8.4	2.938E+01(5.027E-01)	1.195E+00(8.430E-02)	5.641E-01(6.096E-02)
8.4 -- 8.5	1.065E+01(2.953E-01)	7.258E-01(6.665E-02)	4.545E-01(5.324E-02)
8.5 -- 8.6	2.039E+00(1.298E-01)	5.068E-01(5.645E-02)	3.440E-01(4.613E-02)
8.6 -- 8.7	1.141E+00(9.856E-02)	3.767E-01(4.888E-02)	2.543E-01(3.997E-02)
8.7 -- 8.8	6.699E-01(7.417E-02)	4.042E-01(4.902E-02)	2.007E-01(3.477E-02)
8.8 -- 8.9	4.044E-01(5.817E-02)	2.300E-01(3.724E-02)	2.411E-01(4.033E-02)
8.9 -- 9.0	4.120E-01(5.849E-02)	2.342E-01(3.841E-02)	2.089E-01(3.554E-02)
9.0 -- 9.1	3.711E-01(5.569E-02)	2.576E-01(3.939E-02)	1.365E-01(2.943E-02)
9.1 -- 9.2	4.321E-01(6.184E-02)	2.739E-01(4.118E-02)	1.746E-01(3.343E-02)
9.2 -- 9.3	3.578E-01(5.460E-02)	2.499E-01(3.924E-02)	1.134E-01(2.623E-02)
9.3 -- 9.4	2.695E-01(4.745E-02)	1.715E-01(3.327E-02)	1.233E-01(2.857E-02)
9.4 -- 9.5	3.468E-01(5.466E-02)	1.080E-01(2.553E-02)	4.819E-02(1.744E-02)
9.5 -- 9.6	2.617E-01(4.592E-02)	1.181E-01(2.705E-02)	6.318E-02(1.987E-02)
9.6 -- 9.7	2.211E-01(4.299E-02)	1.396E-01(2.925E-02)	8.135E-02(2.205E-02)
9.7 -- 9.8	2.185E-01(4.237E-02)	1.301E-01(2.914E-02)	7.439E-02(2.079E-02)
9.8 -- 9.9	1.421E-01(3.471E-02)	9.582E-02(2.419E-02)	6.625E-02(1.958E-02)
9.9 -- 10.0	1.468E-01(3.487E-02)	7.420E-02(2.213E-02)	2.295E-02(1.149E-02)
10.0 -- 10.1	1.773E-01(3.807E-02)	9.128E-02(2.480E-02)	3.854E-02(1.555E-02)
10.1 -- 10.2	2.109E-01(4.235E-02)	9.382E-02(2.409E-02)	4.226E-02(1.523E-02)
10.2 -- 10.3	2.275E-01(4.389E-02)	8.526E-02(2.235E-02)	5.517E-02(1.923E-02)
10.3 -- 10.4	1.462E-01(3.468E-02)	7.558E-02(2.119E-02)	5.018E-02(1.824E-02)
10.4 -- 10.5	1.378E-01(3.177E-02)	5.683E-02(1.839E-02)	1.642E-02(9.990E-03)
10.5 -- 10.6	1.929E-01(4.070E-02)	4.585E-02(1.553E-02)	6.400E-04(1.770E-03)
10.6 -- 10.7	1.736E-01(3.743E-02)	9.914E-02(2.471E-02)	4.275E-02(1.455E-02)
10.7 -- 10.8	1.506E-01(3.496E-02)	6.661E-02(2.099E-02)	4.779E-02(1.597E-02)
10.8 -- 10.9	1.499E-01(3.490E-02)	6.358E-02(1.935E-02)	2.992E-02(1.360E-02)
10.9 -- 11.0	1.078E-01(2.954E-02)	6.936E-02(2.089E-02)	3.962E-02(1.465E-02)
11.0 -- 11.1	1.104E-01(2.952E-02)	7.451E-02(2.073E-02)	6.044E-02(1.932E-02)
11.1 -- 11.2	1.047E-01(2.900E-02)	4.364E-02(1.703E-02)	2.317E-02(1.098E-02)
11.2 -- 11.3	1.483E-01(3.502E-02)	7.208E-02(2.167E-02)	4.183E-02(1.611E-02)
11.3 -- 11.4	1.083E-01(3.114E-02)	9.289E-02(2.392E-02)	3.340E-02(1.495E-02)
11.4 -- 11.5	1.872E-01(4.067E-02)	9.248E-02(2.412E-02)	6.060E-02(2.060E-02)
11.5 -- 11.6	1.170E-01(2.910E-02)	1.089E-01(2.665E-02)	6.148E-02(1.945E-02)
11.6 -- 11.7	1.092E-01(3.011E-02)	9.113E-02(2.367E-02)	3.796E-02(1.388E-02)
11.7 -- 11.8	2.621E-01(4.719E-02)	9.389E-02(2.457E-02)	7.498E-02(2.190E-02)
11.8 -- 11.9	1.685E-01(3.737E-02)	1.261E-01(2.888E-02)	8.453E-02(2.350E-02)
11.9 -- 12.0	1.101E-01(3.069E-02)	1.805E-01(3.271E-02)	6.522E-02(2.113E-02)
12.0 -- 12.1	1.956E-01(4.108E-02)	1.035E-01(2.523E-02)	4.372E-02(1.655E-02)
12.1 -- 12.2	2.235E-01(4.375E-02)	1.550E-01(3.135E-02)	4.463E-02(1.712E-02)
12.2 -- 12.3	2.708E-01(4.609E-02)	7.838E-02(2.191E-02)	4.735E-02(1.536E-02)
12.3 -- 12.4	3.119E-01(5.143E-02)	1.100E-01(2.682E-02)	7.223E-02(2.204E-02)
12.4 -- 12.5	1.728E-01(3.733E-02)	9.804E-02(2.394E-02)	4.466E-02(1.824E-02)
12.5 -- 12.6	1.950E-01(3.924E-02)	7.753E-02(2.147E-02)	7.282E-02(2.000E-02)
12.6 -- 12.7	1.468E-01(3.610E-02)	9.449E-02(2.392E-02)	5.211E-02(1.723E-02)
12.7 -- 12.8	1.271E-01(3.226E-02)	7.953E-02(2.207E-02)	1.642E-01(3.186E-02)
12.8 -- 12.9	1.733E-01(3.830E-02)	1.034E-01(2.616E-02)	1.695E-01(3.286E-02)
12.9 -- 13.0	9.917E-02(2.888E-02)	1.400E-01(2.936E-02)	1.303E-01(3.006E-02)

<< 16O(p,p'x) Ep = 16 MeV >> *** DDX (error) in [mb/MeV*sr] ***

Ep' (MeV)	90 deg.	100 deg.	110 deg.
13.0 -- 13.1	1.806E-01(3.984E-02)	1.576E-01(3.164E-02)	1.573E-01(3.307E-02)
13.1 -- 13.2	1.578E-01(3.758E-02)	3.057E-01(4.320E-02)	1.682E-01(3.216E-02)
13.2 -- 13.3	2.210E-01(4.408E-02)	3.813E-01(4.953E-02)	1.499E-01(2.987E-02)
13.3 -- 13.4	3.274E-01(5.179E-02)	3.440E-01(4.693E-02)	2.453E+00(1.310E-01)
13.4 -- 13.5	4.607E-01(6.245E-02)	4.748E-01(5.497E-02)	2.698E+01(4.193E-01)
13.5 -- 13.6	6.475E-01(7.409E-02)	5.342E-01(5.707E-02)	3.010E+01(4.384E-01)
13.6 -- 13.7	7.238E-01(7.724E-02)	8.876E+00(2.476E-01)	5.772E+00(1.881E-01)
13.7 -- 13.8	6.102E-01(7.102E-02)	8.491E+01(7.428E-01)	1.608E+00(9.951E-02)
13.8 -- 13.9	7.981E-01(8.213E-02)	7.407E+01(6.901E-01)	1.013E+00(8.035E-02)
13.9 -- 14.0	1.061E+01(3.116E-01)	1.114E+01(2.589E-01)	6.802E-01(6.523E-02)
14.0 -- 14.1	1.422E+02(1.129E+00)	3.545E+00(1.462E-01)	4.514E-01(5.265E-02)
14.1 -- 14.2	1.721E+02(1.296E+00)	2.241E+00(1.171E-01)	4.411E-01(5.234E-02)
14.2 -- 14.3	2.881E+01(4.997E-01)	1.347E+00(9.047E-02)	2.412E-01(3.910E-02)
14.3 -- 14.4	7.386E+00(2.453E-01)	8.920E-01(7.437E-02)	1.904E-01(3.440E-02)
14.4 -- 14.5	4.116E+00(1.828E-01)	6.457E-01(6.311E-02)	1.274E-01(2.758E-02)
14.5 -- 14.6	2.666E+00(1.476E-01)	5.073E-01(5.524E-02)	1.977E-01(3.591E-02)
14.6 -- 14.7	1.776E+00(1.208E-01)	5.100E-01(5.614E-02)	1.255E-01(2.813E-02)
14.7 -- 14.8	1.305E+00(1.030E-01)	2.788E-01(4.170E-02)	1.049E-01(2.471E-02)
14.8 -- 14.9	1.217E+00(1.015E-01)	2.725E-01(4.086E-02)	1.163E-01(2.721E-02)
14.9 -- 15.0	8.399E-01(8.184E-02)	2.209E-01(3.664E-02)	1.358E-01(3.021E-02)
15.0 -- 15.1	7.765E-01(8.027E-02)	2.969E-01(4.247E-02)	3.697E-02(1.494E-02)
15.1 -- 15.2	6.288E-01(7.245E-02)	1.703E-01(3.172E-02)	3.289E-02(1.471E-02)
15.2 -- 15.3	6.002E-01(7.114E-02)	1.265E-01(2.823E-02)	4.326E-02(1.538E-02)
15.3 -- 15.4	4.090E-01(5.727E-02)	7.667E-02(2.185E-02)	3.741E-02(1.530E-02)
15.4 -- 15.5	2.389E-01(4.381E-02)	8.661E-02(2.237E-02)	2.926E-02(1.431E-02)
15.5 -- 15.6	2.218E-01(4.370E-02)	1.167E-01(2.739E-02)	4.276E-02(1.698E-02)
15.6 -- 15.7	2.313E-01(4.397E-02)	6.329E-02(2.018E-02)	1.619E-02(9.930E-03)
15.7 -- 15.8	1.664E-01(3.784E-02)	6.448E-02(2.002E-02)	0.000E+00(0.000E+00)
15.8 -- 15.9	1.239E-01(2.992E-02)	4.985E-02(1.838E-02)	1.784E-02(1.033E-02)
15.9 -- 16.0	1.081E-01(2.857E-02)	4.628E-02(1.714E-02)	6.260E-03(6.830E-03)
16.0 -- 16.1	***** (*****)	***** (*****)	***** (*****)
16.1 -- 16.2	***** (*****)	***** (*****)	***** (*****)
16.2 -- 16.3	***** (*****)	***** (*****)	***** (*****)
16.3 -- 16.4	***** (*****)	***** (*****)	***** (*****)
16.4 -- 16.5	***** (*****)	***** (*****)	***** (*****)
16.5 -- 16.6	***** (*****)	***** (*****)	***** (*****)
16.6 -- 16.7	***** (*****)	***** (*****)	***** (*****)
16.7 -- 16.8	***** (*****)	***** (*****)	***** (*****)
16.8 -- 16.9	***** (*****)	***** (*****)	***** (*****)
16.9 -- 17.0	***** (*****)	***** (*****)	***** (*****)

<< 160(p,p')x Ep = 16 MeV >> *** DDX (error) in [mb/MeV*sr] ***

Ep' (MeV)	120 deg.	130 deg.	140 deg.
3.0 -- 3.1	1.542E+00(6.771E-02)	1.425E+00(6.135E-02)	1.658E+00(7.384E-02)
3.1 -- 3.2	2.566E+00(8.681E-02)	1.515E+00(6.291E-02)	1.878E+00(7.831E-02)
3.2 -- 3.3	2.114E+00(7.854E-02)	1.825E+00(6.899E-02)	1.982E+00(8.101E-02)
3.3 -- 3.4	1.729E+00(7.043E-02)	1.738E+00(6.733E-02)	2.026E+00(8.257E-02)
3.4 -- 3.5	1.638E+00(6.889E-02)	1.705E+00(6.669E-02)	2.779E+00(9.618E-02)
3.5 -- 3.6	1.469E+00(6.530E-02)	2.248E+00(7.732E-02)	3.386E+00(1.055E-01)
3.6 -- 3.7	1.704E+00(7.116E-02)	4.278E+00(1.053E-01)	2.384E+00(8.836E-02)
3.7 -- 3.8	3.730E+00(1.054E-01)	3.032E+00(8.819E-02)	1.822E+00(7.756E-02)
3.8 -- 3.9	4.771E+00(1.176E-01)	1.700E+00(6.669E-02)	2.419E+00(9.027E-02)
3.9 -- 4.0	2.186E+00(7.955E-02)	1.688E+00(6.688E-02)	6.840E+00(1.520E-01)
4.0 -- 4.1	1.539E+00(6.672E-02)	3.827E+00(1.013E-01)	6.065E+00(1.403E-01)
4.1 -- 4.2	1.797E+00(7.279E-02)	5.927E+00(1.235E-01)	3.294E+00(1.043E-01)
4.2 -- 4.3	4.702E+00(1.170E-01)	2.953E+00(8.694E-02)	2.811E+00(9.682E-02)
4.3 -- 4.4	3.579E+00(1.003E-01)	2.142E+00(7.522E-02)	2.226E+00(8.598E-02)
4.4 -- 4.5	2.006E+00(7.703E-02)	1.916E+00(7.104E-02)	1.632E+00(7.332E-02)
4.5 -- 4.6	1.656E+00(7.058E-02)	1.489E+00(6.336E-02)	1.117E+00(6.082E-02)
4.6 -- 4.7	1.450E+00(6.599E-02)	1.171E+00(5.569E-02)	1.184E+00(6.294E-02)
4.7 -- 4.8	1.005E+00(5.471E-02)	8.405E-01(4.716E-02)	3.904E+00(1.172E-01)
4.8 -- 4.9	8.008E-01(4.895E-02)	1.612E+00(6.687E-02)	9.395E+00(1.794E-01)
4.9 -- 5.0	6.414E-01(4.381E-02)	9.600E+00(1.651E-01)	5.255E+00(1.318E-01)
5.0 -- 5.1	3.307E+00(1.023E-01)	9.840E+00(1.620E-01)	1.757E+00(7.644E-02)
5.1 -- 5.2	1.489E+01(2.168E-01)	2.696E+00(8.390E-02)	1.209E+00(6.354E-02)
5.2 -- 5.3	8.850E+00(1.612E-01)	1.205E+00(5.651E-02)	8.993E-01(5.480E-02)
5.3 -- 5.4	1.951E+00(7.560E-02)	8.372E-01(4.679E-02)	6.601E-01(4.742E-02)
5.4 -- 5.5	9.672E-01(5.317E-02)	6.062E-01(3.988E-02)	6.008E-01(4.500E-02)
5.5 -- 5.6	6.645E-01(4.439E-02)	5.444E-01(3.815E-02)	5.223E-01(4.195E-02)
5.6 -- 5.7	5.592E-01(4.043E-02)	5.003E-01(3.634E-02)	4.857E-01(4.049E-02)
5.7 -- 5.8	4.297E-01(3.570E-02)	4.292E-01(3.369E-02)	4.303E-01(3.831E-02)
5.8 -- 5.9	3.609E-01(3.220E-02)	3.350E-01(2.959E-02)	4.175E-01(3.754E-02)
5.9 -- 6.0	2.831E-01(2.871E-02)	2.901E-01(2.749E-02)	2.995E-01(3.183E-02)
6.0 -- 6.1	2.592E-01(2.713E-02)	2.587E-01(2.637E-02)	3.297E-01(3.340E-02)
6.1 -- 6.2	2.326E-01(2.587E-02)	2.778E-01(2.728E-02)	3.278E-01(3.368E-02)
6.2 -- 6.3	2.381E-01(2.613E-02)	2.524E-01(2.562E-02)	1.469E+00(7.166E-02)
6.3 -- 6.4	2.710E-01(2.822E-02)	3.108E-01(2.917E-02)	9.915E+00(1.886E-01)
6.4 -- 6.5	1.773E-01(2.266E-02)	3.026E+00(9.302E-02)	1.265E+01(2.079E-01)
6.5 -- 6.6	1.840E-01(2.345E-02)	1.280E+01(1.887E-01)	8.812E+00(1.717E-01)
6.6 -- 6.7	2.737E+00(9.303E-02)	9.719E+00(1.598E-01)	5.795E+00(1.372E-01)
6.7 -- 6.8	1.106E+01(1.833E-01)	8.317E+00(1.470E-01)	2.351E+00(8.783E-02)
6.8 -- 6.9	7.363E+00(1.464E-01)	3.984E+00(1.007E-01)	1.473E+00(7.002E-02)
6.9 -- 7.0	7.695E+00(1.486E-01)	1.362E+00(5.909E-02)	9.421E-01(5.564E-02)
7.0 -- 7.1	3.200E+00(9.453E-02)	8.736E-01(4.784E-02)	8.429E-01(5.344E-02)
7.1 -- 7.2	9.704E-01(5.274E-02)	6.585E-01(4.128E-02)	4.346E+00(1.230E-01)
7.2 -- 7.3	6.077E-01(4.143E-02)	6.637E-01(4.204E-02)	2.135E+01(2.678E-01)
7.3 -- 7.4	4.962E-01(3.760E-02)	6.071E+00(1.295E-01)	2.048E+01(2.582E-01)
7.4 -- 7.5	4.476E-01(3.653E-02)	2.385E+01(2.493E-01)	7.734E+00(1.579E-01)
7.5 -- 7.6	4.850E+00(1.229E-01)	1.664E+01(2.072E-01)	3.119E+00(1.008E-01)
7.6 -- 7.7	2.129E+01(2.503E-01)	4.913E+00(1.108E-01)	1.996E+00(8.079E-02)
7.7 -- 7.8	1.719E+01(2.227E-01)	2.025E+00(7.164E-02)	1.447E+00(6.892E-02)
7.8 -- 7.9	4.781E+00(1.146E-01)	1.341E+00(5.816E-02)	1.018E+00(5.761E-02)
7.9 -- 8.0	1.616E+00(6.742E-02)	9.913E-01(4.998E-02)	8.488E-01(5.305E-02)

<< 160(p,p'x) Ep = 16 MeV >> *** DDX (error) in [mb/MeV*sr] ***

Ep' (MeV)	120 deg.	130 deg.	140 deg.
8.0 -- 8.1	9.386E-01 (5.136E-02)	6.947E-01 (4.212E-02)	7.895E-01 (5.108E-02)
8.1 -- 8.2	6.079E-01 (4.066E-02)	5.406E-01 (3.754E-02)	5.696E-01 (4.332E-02)
8.2 -- 8.3	5.790E-01 (4.044E-02)	4.491E-01 (3.376E-02)	5.078E-01 (4.065E-02)
8.3 -- 8.4	3.814E-01 (3.276E-02)	3.260E-01 (2.897E-02)	4.704E-01 (3.944E-02)
8.4 -- 8.5	3.479E-01 (3.155E-02)	3.180E-01 (2.802E-02)	3.499E-01 (3.294E-02)
8.5 -- 8.6	3.346E-01 (3.093E-02)	2.679E-01 (2.619E-02)	3.480E-01 (3.368E-02)
8.6 -- 8.7	2.238E-01 (2.510E-02)	2.272E-01 (2.407E-02)	2.222E-01 (2.640E-02)
8.7 -- 8.8	1.780E-01 (2.255E-02)	1.983E-01 (2.212E-02)	2.181E-01 (2.645E-02)
8.8 -- 8.9	1.681E-01 (2.181E-02)	1.552E-01 (1.987E-02)	2.076E-01 (2.605E-02)
8.9 -- 9.0	1.405E-01 (2.038E-02)	1.330E-01 (1.823E-02)	1.813E-01 (2.464E-02)
9.0 -- 9.1	1.158E-01 (1.839E-02)	1.349E-01 (1.869E-02)	1.412E-01 (2.141E-02)
9.1 -- 9.2	1.099E-01 (1.739E-02)	1.389E-01 (1.890E-02)	1.022E-01 (1.811E-02)
9.2 -- 9.3	8.128E-02 (1.512E-02)	7.995E-02 (1.417E-02)	9.597E-02 (1.807E-02)
9.3 -- 9.4	6.804E-02 (1.359E-02)	1.043E-01 (1.606E-02)	1.008E-01 (1.814E-02)
9.4 -- 9.5	9.280E-02 (1.608E-02)	8.585E-02 (1.496E-02)	9.153E-02 (1.779E-02)
9.5 -- 9.6	5.089E-02 (1.200E-02)	5.796E-02 (1.217E-02)	1.003E-01 (1.814E-02)
9.6 -- 9.7	4.989E-02 (1.206E-02)	9.654E-02 (1.602E-02)	9.397E-02 (1.717E-02)
9.7 -- 9.8	5.915E-02 (1.286E-02)	6.381E-02 (1.317E-02)	7.243E-02 (1.555E-02)
9.8 -- 9.9	5.494E-02 (1.252E-02)	4.694E-02 (1.091E-02)	8.134E-02 (1.641E-02)
9.9 -- 10.0	3.051E-02 (9.710E-03)	4.532E-02 (1.045E-02)	6.868E-02 (1.527E-02)
10.0 -- 10.1	4.570E-02 (1.146E-02)	4.929E-02 (1.112E-02)	8.333E-02 (1.694E-02)
10.1 -- 10.2	2.978E-02 (8.420E-03)	5.744E-02 (1.218E-02)	5.656E-02 (1.403E-02)
10.2 -- 10.3	5.569E-02 (1.285E-02)	3.762E-02 (9.680E-03)	6.627E-02 (1.507E-02)
10.3 -- 10.4	4.059E-02 (1.017E-02)	4.734E-02 (1.105E-02)	5.805E-02 (1.328E-02)
10.4 -- 10.5	1.509E-02 (6.080E-03)	2.908E-02 (8.700E-03)	7.830E-02 (1.633E-02)
10.5 -- 10.6	2.752E-02 (8.380E-03)	2.613E-02 (7.630E-03)	7.465E-02 (1.610E-02)
10.6 -- 10.7	3.088E-02 (9.060E-03)	3.608E-02 (9.780E-03)	3.199E-02 (1.042E-02)
10.7 -- 10.8	3.913E-02 (1.025E-02)	4.863E-02 (1.109E-02)	8.165E-02 (1.645E-02)
10.8 -- 10.9	2.004E-02 (7.200E-03)	3.917E-02 (9.720E-03)	1.244E-01 (2.039E-02)
10.9 -- 11.0	2.324E-02 (8.230E-03)	4.374E-02 (1.071E-02)	8.318E-02 (1.684E-02)
11.0 -- 11.1	3.396E-02 (9.890E-03)	5.169E-02 (1.183E-02)	6.048E-02 (1.438E-02)
11.1 -- 11.2	2.568E-02 (8.080E-03)	5.705E-02 (1.234E-02)	7.782E-02 (1.654E-02)
11.2 -- 11.3	4.175E-02 (1.076E-02)	3.197E-02 (8.930E-03)	1.190E-01 (1.952E-02)
11.3 -- 11.4	6.642E-02 (1.366E-02)	4.910E-02 (1.121E-02)	5.571E-02 (1.323E-02)
11.4 -- 11.5	1.812E-02 (7.450E-03)	7.437E-02 (1.333E-02)	6.104E-02 (1.427E-02)
11.5 -- 11.6	2.853E-02 (8.640E-03)	5.502E-02 (1.168E-02)	8.119E-02 (1.648E-02)
11.6 -- 11.7	8.071E-02 (1.571E-02)	3.782E-02 (9.720E-03)	6.730E-02 (1.541E-02)
11.7 -- 11.8	5.509E-02 (1.280E-02)	3.134E-02 (8.810E-03)	5.101E-02 (1.318E-02)
11.8 -- 11.9	3.458E-02 (9.740E-03)	4.179E-02 (1.081E-02)	1.343E-01 (2.195E-02)
11.9 -- 12.0	2.183E-02 (7.760E-03)	4.340E-02 (1.084E-02)	1.368E-01 (2.170E-02)
12.0 -- 12.1	2.496E-02 (8.250E-03)	1.049E-01 (1.638E-02)	1.735E-01 (2.415E-02)
12.1 -- 12.2	3.033E-02 (9.130E-03)	1.050E-01 (1.659E-02)	1.981E-01 (2.595E-02)
12.2 -- 12.3	5.013E-02 (1.191E-02)	7.746E-02 (1.389E-02)	2.568E-01 (2.998E-02)
12.3 -- 12.4	9.995E-02 (1.674E-02)	1.327E-01 (1.871E-02)	2.307E-01 (2.822E-02)
12.4 -- 12.5	1.227E-01 (1.853E-02)	1.580E-01 (1.998E-02)	3.136E-01 (3.308E-02)
12.5 -- 12.6	8.440E-02 (1.562E-02)	1.522E-01 (1.948E-02)	2.098E+00 (8.741E-02)
12.6 -- 12.7	7.920E-02 (1.469E-02)	1.442E-01 (1.860E-02)	2.614E+01 (3.268E-01)
12.7 -- 12.8	1.040E-01 (1.692E-02)	4.583E-01 (3.537E-02)	5.843E+01 (4.708E-01)
12.8 -- 12.9	1.372E-01 (1.974E-02)	9.401E+00 (1.612E-01)	2.470E+01 (2.867E-01)
12.9 -- 13.0	1.292E-01 (1.863E-02)	3.864E+01 (3.168E-01)	8.475E+00 (1.699E-01)

<< 160(p,p'x) Ep = 16 MeV >> *** DDX (error) in [mb/MeV*sr] ***

Ep' (MeV)	120 deg.	130 deg.	140 deg.
13.0 -- 13.1	6.824E-01(4.535E-02)	2.036E+01(2.302E-01)	4.755E+00(1.272E-01)
13.1 -- 13.2	1.010E+01(1.700E-01)	4.794E+00(1.098E-01)	3.186E+00(1.044E-01)
13.2 -- 13.3	2.152E+01(2.541E-01)	2.308E+00(7.671E-02)	2.187E+00(8.569E-02)
13.3 -- 13.4	6.107E+00(1.301E-01)	1.541E+00(6.245E-02)	1.662E+00(7.506E-02)
13.4 -- 13.5	1.566E+00(6.499E-02)	1.120E+00(5.308E-02)	1.253E+00(6.555E-02)
13.5 -- 13.6	7.549E-01(4.487E-02)	8.111E-01(4.559E-02)	1.022E+00(5.888E-02)
13.6 -- 13.7	5.189E-01(3.743E-02)	6.323E-01(4.040E-02)	8.562E-01(5.374E-02)
13.7 -- 13.8	3.239E-01(2.928E-02)	4.709E-01(3.445E-02)	6.564E-01(4.732E-02)
13.8 -- 13.9	2.745E-01(2.709E-02)	3.955E-01(3.188E-02)	5.329E-01(4.218E-02)
13.9 -- 14.0	2.333E-01(2.474E-02)	2.619E-01(2.561E-02)	5.064E-01(4.165E-02)
14.0 -- 14.1	1.817E-01(2.239E-02)	2.184E-01(2.368E-02)	3.381E-01(3.394E-02)
14.1 -- 14.2	1.712E-01(2.175E-02)	2.421E-01(2.498E-02)	3.264E-01(3.341E-02)
14.2 -- 14.3	1.069E-01(1.671E-02)	1.490E-01(1.937E-02)	2.606E-01(2.992E-02)
14.3 -- 14.4	9.984E-02(1.619E-02)	9.452E-02(1.555E-02)	2.426E-01(2.891E-02)
14.4 -- 14.5	7.960E-02(1.446E-02)	1.054E-01(1.689E-02)	1.750E-01(2.481E-02)
14.5 -- 14.6	3.799E-02(1.003E-02)	8.878E-02(1.522E-02)	1.441E-01(2.211E-02)
14.6 -- 14.7	3.981E-02(1.069E-02)	9.791E-02(1.613E-02)	1.249E-01(2.031E-02)
14.7 -- 14.8	5.381E-02(1.182E-02)	7.891E-02(1.446E-02)	1.059E-01(1.906E-02)
14.8 -- 14.9	6.661E-02(1.329E-02)	6.095E-02(1.245E-02)	1.071E-01(1.926E-02)
14.9 -- 15.0	3.823E-02(1.006E-02)	6.105E-02(1.272E-02)	8.056E-02(1.634E-02)
15.0 -- 15.1	3.167E-02(8.690E-03)	5.615E-02(1.196E-02)	5.355E-02(1.388E-02)
15.1 -- 15.2	3.804E-02(1.002E-02)	5.453E-02(1.177E-02)	3.885E-02(1.159E-02)
15.2 -- 15.3	2.499E-02(8.380E-03)	2.643E-02(8.150E-03)	3.772E-02(1.123E-02)
15.3 -- 15.4	3.609E-02(9.800E-03)	2.982E-02(8.510E-03)	4.850E-02(1.269E-02)
15.4 -- 15.5	1.704E-02(6.560E-03)	3.205E-02(9.060E-03)	4.167E-02(1.212E-02)
15.5 -- 15.6	6.590E-03(3.860E-03)	1.970E-02(7.200E-03)	3.332E-02(1.108E-02)
15.6 -- 15.7	1.850E-02(7.230E-03)	1.660E-02(6.480E-03)	3.544E-02(1.072E-02)
15.7 -- 15.8	6.730E-03(4.400E-03)	1.204E-02(5.790E-03)	1.527E-02(7.490E-03)
15.8 -- 15.9	1.486E-02(6.630E-03)	1.539E-02(6.320E-03)	2.191E-02(8.590E-03)
15.9 -- 16.0	2.890E-03(2.660E-03)	2.990E-03(2.990E-03)	1.266E-02(6.610E-03)
16.0 -- 16.1	***** (*****)	***** (*****)	***** (*****)
16.1 -- 16.2	***** (*****)	***** (*****)	***** (*****)
16.2 -- 16.3	***** (*****)	***** (*****)	***** (*****)
16.3 -- 16.4	***** (*****)	***** (*****)	***** (*****)
16.4 -- 16.5	***** (*****)	***** (*****)	***** (*****)
16.5 -- 16.6	***** (*****)	***** (*****)	***** (*****)
16.6 -- 16.7	***** (*****)	***** (*****)	***** (*****)
16.7 -- 16.8	***** (*****)	***** (*****)	***** (*****)
16.8 -- 16.9	***** (*****)	***** (*****)	***** (*****)
16.9 -- 17.0	***** (*****)	***** (*****)	***** (*****)

<< 160(p,p'x) Ep = 16 MeV >> *** DDX (error) in [mb/MeV*sr] ***

Ep' (MeV)	150 deg.
3.0 -- 3.1	2.529E+00(9.405E-02)
3.1 -- 3.2	2.863E+00(9.993E-02)
3.2 -- 3.3	2.991E+00(1.022E-01)
3.3 -- 3.4	3.360E+00(1.083E-01)
3.4 -- 3.5	3.264E+00(1.066E-01)
3.5 -- 3.6	2.574E+00(9.503E-02)
3.6 -- 3.7	2.637E+00(9.643E-02)
3.7 -- 3.8	5.270E+00(1.374E-01)
3.8 -- 3.9	7.888E+00(1.663E-01)
3.9 -- 4.0	5.430E+00(1.374E-01)
4.0 -- 4.1	4.061E+00(1.193E-01)
4.1 -- 4.2	3.073E+00(1.042E-01)
4.2 -- 4.3	2.424E+00(9.276E-02)
4.3 -- 4.4	1.919E+00(8.205E-02)
4.4 -- 4.5	1.410E+00(7.045E-02)
4.5 -- 4.6	2.304E+00(9.161E-02)
4.6 -- 4.7	5.657E+00(1.442E-01)
4.7 -- 4.8	5.687E+00(1.429E-01)
4.8 -- 4.9	2.813E+00(9.991E-02)
4.9 -- 5.0	1.848E+00(8.091E-02)
5.0 -- 5.1	1.285E+00(6.745E-02)
5.1 -- 5.2	9.890E-01(5.913E-02)
5.2 -- 5.3	7.993E-01(5.374E-02)
5.3 -- 5.4	7.153E-01(5.057E-02)
5.4 -- 5.5	5.939E-01(4.613E-02)
5.5 -- 5.6	5.782E-01(4.530E-02)
5.6 -- 5.7	5.031E-01(4.263E-02)
5.7 -- 5.8	4.678E-01(4.071E-02)
5.8 -- 5.9	4.951E-01(4.216E-02)
5.9 -- 6.0	4.045E-01(3.820E-02)
6.0 -- 6.1	1.070E+00(6.327E-02)
6.1 -- 6.2	5.780E+00(1.492E-01)
6.2 -- 6.3	1.051E+01(1.974E-01)
6.3 -- 6.4	8.444E+00(1.744E-01)
6.4 -- 6.5	6.611E+00(1.524E-01)
6.5 -- 6.6	3.603E+00(1.126E-01)
6.6 -- 6.7	2.083E+00(8.612E-02)
6.7 -- 6.8	1.486E+00(7.299E-02)
6.8 -- 6.9	1.352E+00(6.918E-02)
6.9 -- 7.0	4.074E+00(1.219E-01)
7.0 -- 7.1	1.652E+01(2.438E-01)
7.1 -- 7.2	2.130E+01(2.729E-01)
7.2 -- 7.3	1.177E+01(2.028E-01)
7.3 -- 7.4	5.632E+00(1.405E-01)
7.4 -- 7.5	3.697E+00(1.137E-01)
7.5 -- 7.6	2.522E+00(9.431E-02)
7.6 -- 7.7	1.928E+00(8.228E-02)
7.7 -- 7.8	1.487E+00(7.268E-02)
7.8 -- 7.9	1.231E+00(6.553E-02)
7.9 -- 8.0	1.012E+00(5.960E-02)

<< 160(p,p'x) Ep = 16 MeV >> *** DDX (error) in [mb/MeV*sr] ***

Ep' (MeV)	150 deg.
8.0 -- 8.1	9.086E-01(5.701E-02)
8.1 -- 8.2	6.835E-01(4.901E-02)
8.2 -- 8.3	5.841E-01(4.542E-02)
8.3 -- 8.4	4.739E-01(4.093E-02)
8.4 -- 8.5	3.986E-01(3.781E-02)
8.5 -- 8.6	3.513E-01(3.539E-02)
8.6 -- 8.7	3.174E-01(3.352E-02)
8.7 -- 8.8	3.438E-01(3.542E-02)
8.8 -- 8.9	2.604E-01(3.103E-02)
8.9 -- 9.0	2.324E-01(2.902E-02)
9.0 -- 9.1	2.603E-01(3.041E-02)
9.1 -- 9.2	1.669E-01(2.450E-02)
9.2 -- 9.3	1.558E-01(2.383E-02)
9.3 -- 9.4	1.726E-01(2.506E-02)
9.4 -- 9.5	1.278E-01(2.129E-02)
9.5 -- 9.6	1.354E-01(2.197E-02)
9.6 -- 9.7	1.170E-01(2.024E-02)
9.7 -- 9.8	1.211E-01(2.106E-02)
9.8 -- 9.9	8.808E-02(1.788E-02)
9.9 -- 10.0	8.016E-02(1.698E-02)
10.0 -- 10.1	1.044E-01(1.919E-02)
10.1 -- 10.2	7.635E-02(1.679E-02)
10.2 -- 10.3	8.146E-02(1.742E-02)
10.3 -- 10.4	8.086E-02(1.757E-02)
10.4 -- 10.5	1.056E-01(1.980E-02)
10.5 -- 10.6	7.657E-02(1.693E-02)
10.6 -- 10.7	9.818E-02(1.905E-02)
10.7 -- 10.8	1.103E-01(2.051E-02)
10.8 -- 10.9	1.204E-01(2.138E-02)
10.9 -- 11.0	1.012E-01(1.945E-02)
11.0 -- 11.1	7.346E-02(1.654E-02)
11.1 -- 11.2	8.248E-02(1.742E-02)
11.2 -- 11.3	9.581E-02(1.877E-02)
11.3 -- 11.4	8.598E-02(1.811E-02)
11.4 -- 11.5	6.986E-02(1.622E-02)
11.5 -- 11.6	1.194E-01(2.137E-02)
11.6 -- 11.7	1.264E-01(2.153E-02)
11.7 -- 11.8	1.359E-01(2.256E-02)
11.8 -- 11.9	2.006E-01(2.737E-02)
11.9 -- 12.0	2.235E-01(2.929E-02)
12.0 -- 12.1	2.608E-01(3.093E-02)
12.1 -- 12.2	2.724E-01(3.178E-02)
12.2 -- 12.3	5.511E-01(4.591E-02)
12.3 -- 12.4	5.674E+00(1.542E-01)
12.4 -- 12.5	3.699E+01(4.515E-01)
12.5 -- 12.6	5.269E+01(5.257E-01)
12.6 -- 12.7	2.607E+01(3.318E-01)
12.7 -- 12.8	1.261E+01(2.228E-01)
12.8 -- 12.9	7.505E+00(1.706E-01)
12.9 -- 13.0	4.902E+00(1.380E-01)

<< 16O(p,p'x) Ep = 16 MeV >> *** DDX (error) in [mb/MeV*sr] ***

Ep' (MeV)	150 deg.
13.0 -- 13.1	3.801E+00(1.204E-01)
13.1 -- 13.2	2.875E+00(1.046E-01)
13.2 -- 13.3	2.237E+00(9.196E-02)
13.3 -- 13.4	1.827E+00(8.298E-02)
13.4 -- 13.5	1.476E+00(7.420E-02)
13.5 -- 13.6	1.347E+00(7.119E-02)
13.6 -- 13.7	9.885E-01(6.093E-02)
13.7 -- 13.8	9.835E-01(6.063E-02)
13.8 -- 13.9	6.755E-01(5.024E-02)
13.9 -- 14.0	5.855E-01(4.714E-02)
14.0 -- 14.1	5.062E-01(4.361E-02)
14.1 -- 14.2	4.403E-01(4.039E-02)
14.2 -- 14.3	3.533E-01(3.616E-02)
14.3 -- 14.4	2.819E-01(3.257E-02)
14.4 -- 14.5	2.904E-01(3.313E-02)
14.5 -- 14.6	1.520E-01(2.378E-02)
14.6 -- 14.7	1.903E-01(2.674E-02)
14.7 -- 14.8	1.301E-01(2.196E-02)
14.8 -- 14.9	9.006E-02(1.816E-02)
14.9 -- 15.0	1.111E-01(2.008E-02)
15.0 -- 15.1	1.012E-01(1.941E-02)
15.1 -- 15.2	1.067E-01(1.991E-02)
15.2 -- 15.3	9.435E-02(1.870E-02)
15.3 -- 15.4	4.677E-02(1.359E-02)
15.4 -- 15.5	4.521E-02(1.266E-02)
15.5 -- 15.6	6.331E-02(1.507E-02)
15.6 -- 15.7	6.268E-02(1.550E-02)
15.7 -- 15.8	2.346E-02(9.280E-03)
15.8 -- 15.9	2.120E-02(8.790E-03)
15.9 -- 16.0	2.165E-02(8.940E-03)
16.0 -- 16.1	***** (*****)
16.1 -- 16.2	***** (*****)
16.2 -- 16.3	***** (*****)
16.3 -- 16.4	***** (*****)
16.4 -- 16.5	***** (*****)
16.5 -- 16.6	***** (*****)
16.6 -- 16.7	***** (*****)
16.7 -- 16.8	***** (*****)
16.8 -- 16.9	***** (*****)
16.9 -- 17.0	***** (*****)

Appendix 3 Differential cross sections and analyzing powers of the elastic and inelastic scattering in the $p + {}^{16}\text{O}$ interaction at 14 MeV.

Table A-3-1. Differential cross sections and analyzing powers of elastic proton scattering for 14MeV

angle(C.M.)	$d\sigma/d\Omega(\text{mb/sr})$	error (mb/sr)	A_y	error
26.5	4.076e+2	2.579e+1	-2.410e-2	2.70e-3
31.8	2.565e+2	1.623e+1	-1.527e-1	9.90e-3
42.3	7.183e+1	4.549e+0	-2.436e-1	1.62e-2
52.8	1.681e+1	1.073e+0	-9.422e-1	6.17e-2
63.1	2.196e+1	1.394e+0	-3.341e-1	2.29e-2
73.4	3.894e+1	2.469e+0	1.715e-1	1.25e-2
83.6	4.737e+1	3.006e+0	3.614e-1	2.38e-2
93.6	4.502e+1	2.855e+0	3.840e-1	2.51e-2
103.6	3.713e+1	2.356e+0	1.504e-1	1.20e-2
113.4	2.663e+1	1.692e+0	-3.203e-1	2.25e-2
123.1	1.974e+1	1.260e+0	-8.073e-1	5.34e-2
132.8	1.702e+1	1.086e+0	-6.486e-1	4.34e-2
142.3	1.779e+1	1.130e+0	2.070e-1	1.57e-2
151.8	2.065e+1	1.318e+0	8.735e-1	5.61e-2

Table A-3-2. Differential cross sections and analyzing powers of inelastic proton scattering to $0^+(6.049\text{MeV})+3^-(6.130\text{MeV})$ for 14MeV

angle(C.M.)	$d\sigma/d\Omega(\text{mb/sr})$	error (mb/sr)	A_y	error
32.5	1.158e+1	7.35e-1	5.830e-2	8.90e-3
43.2	1.026e+1	6.53e-1	9.570e-2	1.25e-2
53.8	9.354e+0	5.96e-1	1.224e-1	1.37e-2
64.3	8.694e+0	5.55e-1	1.219e-1	1.44e-2
74.6	7.714e+0	4.93e-1	9.530e-2	1.52e-2
84.9	6.775e+0	4.36e-1	7.060e-2	1.75e-2
94.9	6.104e+0	3.92e-1	-1.150e-2	1.68e-2
104.9	5.679e+0	3.66e-1	-1.400e-1	2.14e-2
114.6	5.509e+0	3.56e-1	-2.763e-1	2.71e-2
124.3	5.834e+0	3.76e-1	-2.646e-1	2.55e-2
133.8	5.899e+0	3.79e-1	-2.002e-1	2.24e-2
143.2	6.219e+0	3.99e-1	-8.640e-2	1.67e-2
152.5	6.221e+0	3.98e-1	1.800e-2	1.47e-2

Table A-3-3. Differential cross sections and analyzing powers of inelastic proton scattering to $2^+(6.919\text{MeV})$ for 14MeV

angle(C.M.)	$d\sigma/d\Omega(\text{mb/sr})$	error (mb/sr)	A_y	error
32.6	2.740e+0	1.79e-1	-1.244e-1	2.68e-2
43.4	2.982e+0	1.97e-1	-1.924e-1	3.20e-2
54.0	2.775e+0	1.85e-1	-2.400e-1	3.66e-2
64.5	2.107e+0	1.43e-1	-2.088e-1	4.08e-2
74.9	1.431e+0	1.03e-1	-2.420e-2	5.26e-2
85.2	1.009e+0	8.10e-2	-7.900e-3	7.35e-2
95.2	8.236e-1	6.93e-2	-1.758e-1	8.49e-2
105.2	8.260e-1	8.10e-2	-5.836e-1	1.355e-1
114.9	1.027e+0	9.20e-2	-5.189e-1	1.132e-1
124.5	1.136e+0	9.40e-2	-5.032e-1	9.72e-2
134.0	1.277e+0	1.00e-1	-4.982e-1	8.39e-2
143.4	1.546e+0	1.14e-1	-4.145e-1	6.71e-2
152.6	1.645e+0	1.17e-1	-3.904e-1	5.98e-2

Table A-3-4. Differential cross sections and analyzing powers of inelastic proton scattering to $1^-(7.1169\text{MeV})$ for 14MeV

angle(C.M.)	$d\sigma/d\Omega(\text{mb/sr})$	error (mb/sr)	A_y	error
32.7	5.786e+0	3.69e-1	3.570e-2	1.33e-2
43.4	6.800e+0	4.36e-1	-4.800e-2	1.58e-2
54.1	6.384e+0	4.09e-1	-1.068e-1	1.69e-2
64.6	5.233e+0	3.36e-1	-1.243e-1	1.95e-2
75.0	4.006e+0	2.60e-1	-1.210e-2	2.14e-2
85.3	2.937e+0	1.95e-1	2.346e-1	3.13e-2
95.3	3.147e+0	2.06e-1	5.297e-1	4.00e-2
105.3	3.412e+0	2.26e-1	5.959e-1	4.47e-2
115.0	3.765e+0	2.48e-1	5.149e-1	4.03e-2
124.6	3.967e+0	2.60e-1	4.827e-1	3.81e-2
134.1	3.844e+0	2.52e-1	4.903e-1	3.90e-2
143.4	3.547e+0	2.32e-1	5.088e-1	3.99e-2
152.7	3.380e+0	2.21e-1	4.933e-1	3.88e-2

Appendix 4 Differential cross sections and analyzing powers of the elastic and inelastic scattering in the $p + {}^{16}\text{O}$ interaction at 16 MeV.

Table A-4-1. Differential cross sections and analyzing powers of elastic proton scattering for 16MeV

angle(C.M.)	$d\sigma/d\Omega(\text{mb/sr})$	error(mb/sr)	A_y	error
26.5	4.293e+2	2.717e+1	-1.461e-1	9.90e-3
31.8	2.611e+2	1.653e+1	-2.403e-1	1.59e-2
42.3	6.103e+1	3.874e+0	-4.967e-1	3.28e-2
52.8	1.333e+1	8.500e-1	-4.603e-1	3.24e-2
63.1	3.145e+1	1.994e+0	-5.630e-2	9.10e-3
73.4	5.235e+1	3.318e+0	-1.342e-1	1.10e-2
83.6	5.248e+1	3.326e+0	-1.432e-1	1.14e-2
93.6	3.675e+1	2.332e+0	-9.700e-2	1.02e-2
103.6	1.895e+1	1.204e+0	-2.330e-2	9.70e-3
113.4	7.008e+0	4.490e-1	-1.123e-1	1.80e-2
123.1	4.294e+0	2.740e-1	-5.647e-1	3.91e-2
132.8	8.100e+0	5.150e-1	-4.880e-2	1.04e-2
142.3	1.302e+1	8.270e-1	3.756e-1	2.54e-2
151.8	1.440e+1	9.180e-1	7.127e-1	4.63e-2

Table A-4-2. Differential cross sections and analyzing powers of inelastic proton scattering to $0^+(6.049\text{MeV})+3^-(6.130\text{MeV})$ for 16MeV

angle(C.M.)	$d\sigma/d\Omega(\text{mb/sr})$	error(mb/sr)	A_y	error
32.3	1.266e+1	8.05e-1	-1.089e-1	1.34e-2
43.0	1.185e+1	7.54e-1	-1.481e-1	1.49e-2
53.6	1.153e+1	7.35e-1	-1.542e-1	1.63e-2
64.1	1.046e+1	6.67e-1	-1.629e-1	1.82e-2
74.4	8.561e+0	5.48e-1	-1.087e-1	1.83e-2
84.6	6.752e+0	4.34e-1	9.530e-2	1.96e-2
94.7	5.145e+0	3.33e-1	1.696e-1	2.39e-2
104.6	4.616e+0	2.98e-1	7.350e-2	2.05e-2
114.4	4.803e+0	3.10e-1	-3.760e-2	2.09e-2
124.1	5.137e+0	3.28e-1	-1.545e-1	1.72e-2
133.6	5.414e+0	3.45e-1	-1.522e-1	1.67e-2
143.0	5.846e+0	3.74e-1	-2.740e-2	1.52e-2
152.3	5.918e+0	3.79e-1	1.158e-1	1.80e-2

Table A-4-3. Differential cross sections and analyzing powers of inelastic proton scattering to $2^+(6.919\text{MeV})$ for 16MeV

angle(C.M.)	$d\sigma/d\Omega(\text{mb/sr})$	error (mb/sr)	A_y	error
32.5	2.603e+0	1.75e-1	-6.630e-2	3.59e-2
43.2	2.082e+0	1.39e-1	-1.392e-1	3.86e-2
53.8	1.637e+0	1.13e-1	-1.119e-1	4.85e-2
64.3	1.418e+0	1.00e-1	-1.131e-1	5.80e-2
74.6	1.429e+0	1.04e-1	-1.556e-1	6.30e-2
84.8	1.510e+0	1.07e-1	-7.400e-3	5.37e-2
94.9	1.408e+0	1.03e-1	-9.620e-2	5.90e-2
104.8	1.391e+0	9.70e-2	-2.412e-1	5.26e-2
114.6	1.433e+0	1.01e-1	-1.595e-1	5.32e-2
124.3	1.419e+0	9.80e-2	-8.360e-2	4.38e-2
133.8	1.577e+0	1.08e-1	4.060e-2	4.17e-2
143.2	1.592e+0	1.13e-1	5.710e-2	5.10e-2
152.5	1.443e+0	1.06e-1	1.609e-1	5.81e-2

Table A-4-4. Differential cross sections and analyzing powers of inelastic proton scattering to 1^- (7.1169MeV) for 16MeV

angle(C.M.)	$d\sigma/d\Omega(\text{mb/sr})$	error (mb/sr)	A_y	error
32.5	2.751e+0	1.83e-1	1.643e-1	3.35e-2
43.2	2.522e+0	1.67e-1	-1.799e-1	3.44e-2
53.8	2.423e+0	1.61e-1	-4.795e-1	4.68e-2
64.3	2.337e+0	1.56e-1	-5.557e-1	5.44e-2
74.7	2.066e+0	1.41e-1	-4.808e-1	5.58e-2
84.9	1.574e+0	1.11e-1	-4.006e-1	6.04e-2
95.0	1.188e+0	9.04e-2	-1.619e-1	7.13e-2
104.9	1.128e+0	8.30e-2	9.380e-2	6.22e-2
114.7	1.431e+0	1.01e-1	1.801e-1	5.16e-2
124.3	2.106e+0	1.38e-1	2.876e-1	3.26e-2
133.8	2.731e+0	1.77e-1	3.099e-1	2.96e-2
143.2	2.983e+0	1.95e-1	3.681e-1	3.41e-2
152.5	2.704e+0	1.78e-1	3.903e-1	3.70e-2