

**JAERI-Tech
95-008**



TOKAMAK ASSEMBLY AND TOOLING

February 1995

**Masataka NAKAHIRA, Eisuke TADA, Naokazu KANAMORI
Satoshi KAKUDATE and Kiyoshi OKA**

**日本原子力研究所
Japan Atomic Energy Research Institute**

本レポートは、日本原子力研究所が不定期に公刊している研究報告書です。
入手の問合わせは、日本原子力研究所技術情報部情報資料課(〒319-11 茨城県那珂郡東海村)あて、お申し越してください。なお、このほかに財団法人原子力弘済会資料センター(〒319-11 茨城県那珂郡東海村日本原子力研究所内)で複写による実費頒布をおこなっております。

This report is issued irregularly.

Inquiries about availability of the reports should be addressed to Information Division, Department of Technical Information, Japan Atomic Energy Research Institute, Tokai-mura, Naka-gun, Ibaraki-ken 319-11, Japan.

© Japan Atomic Energy Research Institute, 1994

編集兼発行 日本原子力研究所
印刷 (株)高野高速印刷

Tokamak Assembly and Tooling

Masataka NAKAHIRA, Eisuke TADA, Naokazu KANAMORI
Satoshi KAKULATE and Kiyoshi OKA

Department of Fusion Engineering Research
Naka Fusion Research Establishment
Japan Atomic Energy Research Institute
Naka-machi, Naka-gun, Ibaraki-ken

(Received January 26, 1995)

In fusion experimental reactors such as ITER, the reactor core will be highly activated due to D-T operation and the components inside the cryostat will have to be assembled and replaced by remote operation. Many of assembly procedures will have to be applied to remote replacement at a later time. Thus, fusion reactors should have replaceable features which accommodate machine layout and structural configuration fully compatible with remote operation.

From this point of view, this paper summarizes investigations about present outline design of ITER and the recommended overall design approach, philosophy and procedures for the assembly and replacement.

Keywords : Fusion Experimental Reactor, Remote Handling Assembly, Tool

トカマク組立及び組立治具の検討

日本原子力研究所那珂研究所核融合工学部

中平 昌隆・多田 栄介・金森 直和・角館 聡
岡 潔

(1995年1月26日受理)

核融合実験炉においては、D-T運転に伴いクライオスタット内にて炉を構成する構造物が放射化され、人の出入りが著しく制限されるため、これらの構造物は遠隔操作により分解組立や保守を行わなければならない。従って、ほとんどの組立手順は遠隔操作で行うことが可能でなければならない。炉本体は自ずと機器構成、構造共に遠隔操作を前提として設計がなされなければならない。

本書は、このような観点に立ち国際熱核融合実験炉（ITER）の現行の構造設計に対する検討結果及び組立や交換についての設計指針や手順についての改善案をとりまとめたものである。

本研究はITER工学設計活動の一環として実施したもので、本報告は1993年ITER設計タスク協定（S10TD01）に基づくものである。

那珂研究所：〒311-01 茨城県那珂郡那珂町大字向山801-1

目 次

1. 序 言	1
1.1 目 的	1
1.2 概 要	1
2. 設計指針	1
2.1 組立・保守分類	2
2.2 組立・保守方法	3
2.3 機器構成	4
2.4 組立精度及び手順	5
3. 組立計画と設計改訂案	6
3.1 真空容器	6
3.2 重力支持	8
3.3 コイル	10
3.4 炉内機器	19
3.5 ポート配置と炉内機器の取り扱い	21
4. 組立手順案	23
4.1 クライオスタット組立	23
4.2 重力支持脚設置	23
4.3 下側PFコイルの設置	23
4.4 TF/VVパラレルモジュール設置	24
4.5 VVウェッジモジュール設置	24
4.6 メカニカルストラクチャ組立	24
4.7 TFキー挿入	24
4.8 CSコイル設置	24
4.9 PFコイル設置	24
4.10 マグネット系配線	24
4.11 マグネット動作テスト	24
4.12 真空容器セクタ溶接	24
4.13 真空容器ポート溶接	25
4.14 炉内機器設置	25
5. 結 言	25
謝 辞	25

Contents

1. Introduction	1
1.1 Objectives of the Study	1
1.2 Scope of the Paper	1
2. Overall Design Approach	1
2.1 Assembly/maintenance Classification	2
2.2 Assembly/maintenance Scheme	3
2.3 Machine Layout and Configuration	4
2.4 Assembly Tolerance and Procedure	5
3. Recommended Assembly Plan and Design Improvements	6
3.1 Vacuum Vessel (VV)	6
3.2 Gravity Support	8
3.3 Magnet Assembly	10
3.4 In-vessel Structures Assembly	19
3.5 Port Arrangement and In-vessel Components Handling	21
4. Recommended Assembly Procedure	23
4.1 Construct Cryostat	23
4.2 Install Gravity Supports	23
4.3 Place Lower PF Coils	23
4.4 Install TF with VV Parallel Module	24
4.5 Install VV Wedge Module	24
4.6 Assemble Mechanical Structure	24
4.7 Fix TF Coils with Keys	24
4.8 Install CS Coil	24
4.9 Install PF Coils	24
4.10 Connect Magnet Termination and Service Lines	24
4.11 Magnet Performance Test	24
4.12 Weld VV Sectors	24
4.13 Weld VV Ports	25
4.14 Install In-vessel Components	25
5. Conclusions	25
Acknowledgement	25

1. Introduction

1.1 Objectives of the study

The objectives of the study are to provide the detail plan of concept, scenario and procedure for the ITER tokamak assembly and to define major specifications, interfaces and schematic design of handling, tooling and associated elements for the assembly.

1.2 Scope of the paper

A scoping study on an assembly procedure of the tokamak main components such as magnets and a vacuum vessel has been conducted in accordance with the outline design of ITER. Based on this, this paper summarizes the recommended overall design approach, philosophy and procedures for the assembly and replacement for the further extensive design study on " ITER tokamak assembly and tooling ".

2. Overall Design Approach

Since the reactor core of ITER will be highly activated once it starts operation, personnel access will be prohibited so that assembly and replacement of the components inside the cryostat will have to be totally conducted by remote handling technology. Many of assembly procedures will have to be applied to remote replacement at a later time. Thus, fusion reactors should have replaceable features which accommodate machine layout and structural configuration fully compatible with remote operation.

In the present outline design, a serious concern is the great interconnection of all major subsystems of the basic device such as a bucking cylinder (BC)/center solenoid (CS) subassembly, toroidal field (TF) and poloidal field (PF) magnets, a vacuum vessel (VV), a mechanical structure (MS). Any intervention on any of those subsystems requires major disconnecting operation of the machine, thereby resulting in extreme complications when performed in remote conditions.

In this regard, the following design approach taking into account the replaceability are highly required to establish the assembly plan and to develop the further engineering design.

1. Introduction

1.1 Objectives of the study

The objectives of the study are to provide the detail plan of concept, scenario and procedure for the ITER tokamak assembly and to define major specifications, interfaces and schematic design of handling, tooling and associated elements for the assembly.

1.2 Scope of the paper

A scoping study on an assembly procedure of the tokamak main components such as magnets and a vacuum vessel has been conducted in accordance with the outline design of ITER. Based on this, this paper summarizes the recommended overall design approach, philosophy and procedures for the assembly and replacement for the further extensive design study on " ITER tokamak assembly and tooling ".

2. Overall Design Approach

Since the reactor core of ITER will be highly activated once it starts operation, personnel access will be prohibited so that assembly and replacement of the components inside the cryostat will have to be totally conducted by remote handling technology. Many of assembly procedures will have to be applied to remote replacement at a later time. Thus, fusion reactors should have replaceable features which accommodate machine layout and structural configuration fully compatible with remote operation.

In the present outline design, a serious concern is the great interconnection of all major subsystems of the basic device such as a bucking cylinder (BC)/center solenoid (CS) subassembly, toroidal field (TF) and poloidal field (PF) magnets, a vacuum vessel (VV), a mechanical structure (MS). Any intervention on any of those subsystems requires major disconnecting operation of the machine, thereby resulting in extreme complications when performed in remote conditions.

In this regard, the following design approach taking into account the replaceability are highly required to establish the assembly plan and to develop the further engineering design.

2.1 Assembly/maintenance classification

The reactor core is composed of blanket, plasma facing components, vacuum vessel, superconducting magnets, cryostat and structural supports: they are operated in the different operating conditions, resulting in different risk potential in terms of reliability. Based on this consideration, the components can be classified into the following four categories.

- 1) Class-1: Scheduled maintenance
- 2) Class-2: Infrequent maintenance
- 3) Class-3: Maintenance in the event of failure
- 4) Class-4: No maintenance

Table 1 shows the recommended classification and maintainability of major components in the reactor core according to the categorization.

The plasma facing components such as divertor and limiters are categorized into the Class-1 component since they are operated in severe heat/particle conditions with big uncertainty of plasma surface interaction and in high radiation conditions caused from 14-MeV neutron.

The blanket is categorized into the Class-2 component because of big technological step from the present technology level and possible replacement from shielding blanket to breeding blanket for high neutron fluence operation.

The superconducting magnets, categorized into the Class-3 component, should be designed to have sufficient reliability during the whole operation period of ITER but unexpected failures have to be considered since the ITER magnet requires a big technological step from the present technology level. Correspondingly, the vacuum vessel is categorized into the Class-3 component as same as magnets since the vacuum vessel has to be disassembled in the case of magnet failure.

Table 1 Component classification and maintainability

Classification	Components	Maintainability
Class-1	Bumper limiter	In-vessel inspection/repair of armor Replacement of a bumper limiter
	Divertor	In-vessel inspection/repair of armor In-vessel replacement of a plate element Replacement of a divertor cassette
Class-2	Shield/Blanket	In-vessel inspection/repair Replacement of each module
Class-3	Magnet	In-situ inspection/repair Independent replacement of PF & TF
	Vacuum vessel	In-situ inspection/repair Replacement of each sector
Class-4	TBD	

Considerations on contamination barrier to avoid dispersion of activated dust during maintenance operation are fundamental requirements for establishing the basic maintenance scheme. For this, a cask is quite essential as a container for transportation of components, which are cleaned and detritiated before maintenance. Although the Class-1 and 2 components can be fully contained within this envelope during maintenance, the Class-3 components can not be contained due to its size and configuration. In this regard, the surface of the Class-3 components should be fully covered by metal so as to achieve perfect cleaning and detritiation before maintenance: electrical insulation like epoxy should not be used for the surface material due to possible absorption and permeation of tritium and activated dust.

2.2 Assembly/maintenance scheme

According to the component classification mentioned above, the following assembly/maintenance schemes are recommended.

(1) Layered maintenance for the Class-1 & 2 components

The plasma facing components such as divertor and bumper limiter are the scheduled maintenance component and require quick and reliable maintenance operation. For such components, a layered structure and corresponding maintenance scheme are recommended as listed in Table 2. In this scheme, the following advantages can be expected.

- 1) Simple and quick maintenance of high risk component such as armor independently from the heavy blanket and divertor structure
- 2) Reduction of rad waste due to light weight of high risk component
- 3) Reliable maintenance operation due to redundancy

Table 2 Layered structure and maintenance for class-1 & 2 component

First wall/blanket	
(1)Armor	(1)In-vessel maintenance
(2)Bumper limiter	(2)In-vessel maintenance
(3)Blanket structure	(3)Maintenance from top port
Divertor	
(1)Armor	(1)In-vessel maintenance
(2)Plate element	(2)In-vessel maintenance
(3)Divertor structure	(3)Cassette maintenance from pumping duct

(2) Module or sector maintenance for the Class-3 components

The superconducting magnets and vacuum vessel are categorized into the Class-3 component. For such heavy components, it is highly requested to segment into a module or sector for achieving individual maintenance in simple motion without interaction each other.

(3) Machine assembly

The initial assembly of the machine should also be performed in full remote operation as much as possible for finalization of remote handling system. Recommended assembly schemes of major components shown in Table 3 are based on the following philosophy.

- 1) Segmented and sector assembly for easy remote operation
- 2) Repeatable procedure with common tools for reliable remote operation
- 3) Simple structure for assembling without complex motion and alignment adjustment

Table 3 Recommended assembly scheme

Component	Assembly scheme
Vacuum vessel	Unit assembly of sector modules compatible with TF magnet assembly without rotation
CS/PF coils	Independent assembly without retracting TF magnets
TF magnet	Unit assembly with vacuum vessel
Blanket	Modular assembly from top port
Divertor	Modular assembly (in-vessel and/or cassette from pumping duct)

2.3 Machine layout and configuration

In order to accommodate machine layout and structural configuration fully compatible with assembly/maintenance plan in remote operation, the following issues are taken into the design consideration.

(1) Port opening

Machine layout should provide sufficient space for access of remote handling equipment and for replacement of in-vessel components.

(2) Structural segmentation

Components to be maintained should be simply replaceable and fully segmented into modules in order to achieve easy assembly and maintenance of a failed module without complex motion. In addition, it is essential to reduce the handling weight of components down to the present technology level of around 1,300 ton with indoor crane: segmentation of CS/BC and MS must be reconsidered. Even for the blanket module, structural segmentation must be reconsidered according to the risk potential assessment so as to reduce the handling weight, simplify the handling motion, and to achieve more quick maintenance

operation. For this, layered/blocked structure is an attractive concept: first wall, shield and breeding structures are separated for the independent assembly/maintenance and the breeding structure is a highly segmented structure like a block which can be inserted/supported into/with the shield structure.

(3) Structural supports

Components to be maintained should be independently supported from others so as to achieve individual assembly and maintenance without interaction. Deformation during welding on site must be taken into consideration, though its reduction are tried as such as possible. Adjustable connection geometry and robust in-vessel supports are required to accommodate such deformation in ITER.

(4) Machine interfaces

The structural interfaces of every component should be robust to allow misalignment/gaps for assembly and alignment mechanism compatible with remote handling is required.

(5) Personal access

Superconducting magnets require complex connections for current termination and insulation breaks. The location of such connections must be considered to allow personnel access for their hand on maintenance as much as possible.

2.4 Assembly tolerance and procedure

(1) Pre-assembly

Pre-assembly of subsystems at factory should be adopted as much as possible so as to improve assembly tolerance, minimize unexpected interfaces between each component, prevent complex adjustment, machining and connection on site, and save installation period. It is required to improve the present structural design of ITER since almost all of assembly is performed on site due to integrated structural supports and the assembly tolerance can be only verified in place.

(2) Installation tolerance

According to the assembly experiences on large tokamak and superconducting magnets, installation tolerances are in the level of 3 mm, which has been achieved mainly by alignment with shim/liner adjustment, and direct handling by workers. In ITER, it is essential to develop remote handling equipment and simple alignment mechanism for achieving accurate installation tolerance. In addition, installation tolerance can be assured by rigid foundation like lower mechanical supports without having any kinematics. Rigid base as a sound

foundation and benchmark during installation of components are required for ITER.

(3) Assembly clearance

Based on the experiences on handling heavy components, assembly clearance between components is in the range of 20 to 35 mm in the case of simple vertical movement of highly symmetric and rigid structure with manual assistance and observation. For assembling the ITER components, the following issues are taken into consideration:

- 1) To simplify component configuration and movement for assembly
- 2) To increase assembly clearance taking into account the deformation of their dead weight
- 3) To provide guide structure for mitigating lateral movement of components and for fine positioning

(4) Magnet performance test

During assembly, the basic performance of each component must be verified in each assembly step sequentially. In particular, performance tests of TF and PF magnets should be conducted in order to finalize the magnet system in the ITER operating conditions and to find out an initial failure which will be possibly likelihood. In this regard, the performance tests on magnet system before full welding of vacuum vessel must be planned in order to verify their total performance and to replace a magnet without extra cutting/welding of vacuum vessel if failed. The vacuum vessel sectors and ports are connected together with full penetration welding after the coil performance test.

3. Recommended Assembly Plan and Design Improvements

Efforts have been made to develop the overall assembly and maintenance plan in accordance with the present outline design report and the overall design approach mentioned above. As a result, critical issues have been found from the remote handling perspective and the following design improvements and assembly plan are recommended.

3.1 Vacuum vessel (VV)

Critical issues: The present VV segmentation for initial assembly is located at the center of TF magnet in order to reduce the number of welding line and to achieve reliable welding connection on site. However, this requires to rotate the whole vacuum vessel after full welding of the VV connections and huge assembly system including complex adjustment mechanism is required for fine positioning of large, heavy

foundation and benchmark during installation of components are required for ITER.

(3) Assembly clearance

Based on the experiences on handling heavy components, assembly clearance between components is in the range of 20 to 35 mm in the case of simple vertical movement of highly symmetric and rigid structure with manual assistance and observation. For assembling the ITER components, the following issues are taken into consideration:

- 1) To simplify component configuration and movement for assembly
- 2) To increase assembly clearance taking into account the deformation of their dead weight
- 3) To provide guide structure for mitigating lateral movement of components and for fine positioning

(4) Magnet performance test

During assembly, the basic performance of each component must be verified in each assembly step sequentially. In particular, performance tests of TF and PF magnets should be conducted in order to finalize the magnet system in the ITER operating conditions and to find out an initial failure which will be possibly likelihood. In this regard, the performance tests on magnet system before full welding of vacuum vessel must be planned in order to verify their total performance and to replace a magnet without extra cutting/welding of vacuum vessel if failed. The vacuum vessel sectors and ports are connected together with full penetration welding after the coil performance test.

3. Recommended Assembly Plan and Design Improvements

Efforts have been made to develop the overall assembly and maintenance plan in accordance with the present outline design report and the overall design approach mentioned above. As a result, critical issues have been found from the remote handling perspective and the following design improvements and assembly plan are recommended.

3.1 Vacuum vessel (VV)

Critical issues: The present VV segmentation for initial assembly is located at the center of TF magnet in order to reduce the number of welding line and to achieve reliable welding connection on site. However, this requires to rotate the whole vacuum vessel after full welding of the VV connections and huge assembly system including complex adjustment mechanism is required for fine positioning of large, heavy

and thin structure: this scheme is not compatible with the magnet performance test be conducted before the VV full welding for their initial check. Moreover, additional field joints are to be considered for the maintenance purpose since such rotation is not feasible for remote handling and a sector maintenance can not be attained.

In the present design, the field joint for maintenance is planned at the center of the port between TF magnets, which requires complex welding for the connection of port base and extension where high electromagnetic loads are applied. In this regard, it seems to be questionable to have a segmentation at the center of port. Furthermore, the radial movement for removal of the sector is highly limited due to the mechanical structure (MS) configuration and layout.

Recommendations: It is recommended to improve the present design on the VV segmentation and MS configuration so as to avoid the rotation of the whole vacuum vessel, to have a common assembly scheme for initial assembly and maintenance, and to allow the retraction of a sector in the radial direction during maintenance.

Possible options:

1) Parallel/wedge segmentation for VV

In this scheme, VV is segmented into 24 parallel modules and 24 wedge modules: this gives simple welding line, compatibility for the magnet performance test and maintenance scheme. The port base can be pre-assembled with the wedge module, so that port connection on site is much simpler and reliable. Example of this segmentation is shown in Fig. 3.1.1. This option requires improvements of MS structural design so as to allow the radial movement for retracting wedge modules (See 3.3 (7)). The number of welding line is twice compared with the present segmentation at the center of TF magnet but much reliable connection around the port can be achieved.

Preliminary studies on assembly system for the VV rotation:

1) TF/VV sub-assembly installation (Fig. 3.1.2)

TF/VV sub-assembly is hung with L-shaped jig. The jig consists of 3 pieces. One is a vertical beam that supports the inboard part of the TF coil. Others are horizontal beams that lift the TF coil through the crevices and VV through the VV stiffener. The horizontal beams are separated into two pieces and one of the horizontal beams connected to the VV can be rotated using a wheel for the rotation of VV.

VV stiffeners are set inside VV and are designed to support VV against deflection caused by the dead weight. Some of them are used for VV hanging. The hanging points are located at the hinges for blankets. The vacuum vessel internal support should be put through the center of

gravity. TF stiffeners set inside VV are attached to the TF bore surface through the upper vertical ports and don't support the whole dead weight of TF, but support the reacting force from deflection of TF. The dead weight and force is supported by the VV internal support through these stiffeners. Accordingly, the hanger beam should be wide enough against the reacting force, and the bolted joint at L-shaped jig should also be strong enough.

2) Ring structure installation (Fig. 3.1.3)

After whole sectors of VV are installed, a ring structure is set on the horizontal beam of L-shaped jig, resulting in the both-ends-supported-beam configuration. By this arrangement, VV can be supported independently from MS. Schematic model of this support concept is shown in Fig. 3.1.6.

3) Vertical beam removal (Fig. 3.1.4)

The whole vertical beams are removed and TF magnets are supported with the regular in-board gravity column.

4) Vacuum vessel internal support removal (Fig. 3.1.5)

VV sectors are welded each other. After that, one of the separated VV internal support is removed prior to rotate VV for one side.

5) Rotate VV

External actuator system is set on the MS and the VV is rotated by 7.5 degree.

3.2 Gravity support

In the present design, two gravity supports are located under the machine: one is for sustaining bucking cylinder (BC), center solenoid (CS) and toroidal field (TF) magnets, and another for vacuum vessel (VV), mechanical structure (MS) and in-vessel components.

(1) Lower PF magnet maintenance

Critical issues: The lower poloidal field coils (PF-6 and 7) are located between the gravity supports and no replacement of the poloidal field magnets is allowed. The superconducting magnet is classified into the Class-3 component because of technical reason and thus the maintainability should be kept.

Recommendations: It is recommended to rearrange the gravity support and lower PF magnets layout so as to allow the lower PF magnet maintenance.

Possible options: Two gravity supports are located the outside of the lower PF magnets which can be replaced or maintained through the tunnel located under the machine, as shown in Figs. 3.2.1 and 3.2.2.

(2) Interaction between magnets and reactor structures

Critical issues: The present gravity support is designed to bridge between the lower poloidal field magnet and VV for compensation of electromagnetic loads. This concept gives complex maintenance operation since independent maintenance of the magnet is not allowed: this also gives less reliability due to high conduction heat to magnets along the supports and due to mechanical disturbance between vacuum vessel and magnet.

Recommendations: It is recommended to install individual gravity support for magnet and vacuum vessel so as to allow independent maintenance of the lower PF magnet. A quantitative analysis on feasibility of this compensating system for electromagnetic loads during fast disruption within 20 msec is also recommended.

Possible options: A separated gravity support, as shown in Fig. 3.2.2, is a possible option to avoid the complexity in maintenance operation, thermal head loads, and mechanical disturbances between magnets and VV.

(3) Mechanical kinematics at gravity supports

Critical issues: In the present design, machine gravity supports with pivoting mechanism provide freedom for the thermal expansion. However, structural design of the machine support for sustaining heavy weight should avoid such kinematics because of its low reliability: this requires maintenance of the support itself and complex remote operation including installation of temporary supports at the time of machine failure. Moreover, since the machine gravity support is the key reference frame of the whole basic device during assembly, the support should be simple and reliable for providing the robust foundation during assembly.

Recommendations: It is recommended to adopt the simple structure without any mechanical kinematics so as to decrease risk potential and to provide a sound base for the assembly.

Possible options: A flexible multi-plate structure without any mechanical kinematics has much advantage by means of simplicity, in comparison with pivoting mechanisms or sliding surfaces. It can provide sufficient flexibility for thermal expansion/contraction in the radial

direction, high reliability due to no kinematics and absolute reference surface as a sound foundation for the machine assembly.

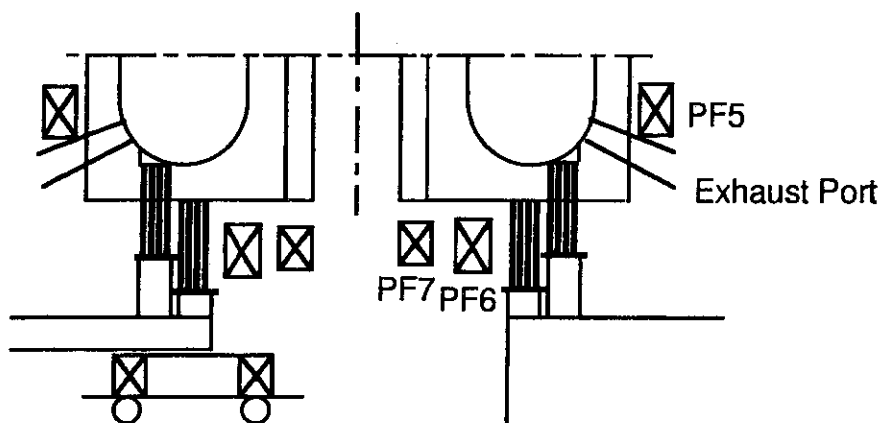

Fig. 3.2.2 Example of gravity support

3.3 Magnet assembly

(1) Assembly tolerance

Critical issues: Based on the experiences on large tokamak and magnets assembly, non-uniform contact at structural interfaces such as TF magnet and CS coil must be taken into account in spite of very precise fabrication tolerance. However, the present design requires perfectly uniform surface contact without misalignment and gaps at several interfaces between TF magnets, CS coil and BC at the same time: the electromagnetic forces of TF magnet and CS coil have to be properly transmitted and compensated through the contact surfaces. (Fig. 3.3.1) The force distribution strongly depends on stiffness of the interfaces taking into account the non-uniformity, gaps and misalignment: it has a high risk potential to cause excessive stress on the magnet winding due to the interfacing uncertainties.

Recommendations: It is recommended to improve the structural design of magnet supports so as to allow misalignment and gaps at least in the range of several mm. A sensitivity analysis to define the allowable misalignment/gaps is requested both for finalizing specifications on the assembly tolerance and for assuring the structural integrity of magnet system.

Possible options: A coil case around the TF winding pack is a possible option to provide robust supports for allowing misalignment and gaps during assembly, and to decrease the number of keys, resulting in less interfaces. In this concept, the coil case is a primary structure and keys as supplementary. A wedge type support is also promising method to

prevent mechanical interaction due to less interfaces and to provide less assembly uncertainties since pre-assembly at factory and modular assembly on site is available for achieving precise assembly tolerance without adjustment and machining on site.

(2) Gap management

Critical issues: In the present design, it is assumed that BC wedge segments and keys assembled without misalignment and gaps at room temperature become loose contact after cooldown to 4 K and are accurately restored to the original tightness due to TF centering force. However, in the reality, loosen wedges and keys are unstable and can not be expected to recover the original fixation. In addition, effect of the initial misalignment and gaps should be taken into consideration.

Recommendations: It is recommended to maintain the assembly tightness at room temperature down to 4 K.

Possible options: The assembly tightness at room temperature can be maintained by adopting stainless steel for the CS structural materials: the axial pre-compression of CS coil is applied by a combination of tight bolt at room temperature and wedge insertion at 4 K. Another option is to separate the mechanical interaction between TF magnet and CS coil such as wedge type support. In this case, the initial assembly tightness of TF magnets can be kept regardless of the CS structural materials.

(3) Modular assembly

Critical issues: In the present design, TF magnets, CS coil and bucking cylinder have to be assembled uniformly at the same time on site: this requires on-site machining for alignment adjustment of enormous number of wedges, keys and interfaces since this procedure is not tolerable with modular pre-assembly at factory and the installation alignment is only determined in the initial assembly on site.

Recommendations: It is recommended to improve the structural design of magnet supports so as to perform alignment adjustment at factory and to minimize adjustment/machining on site.

Possible options: A coil case around the TF winding pack is a possible option to reduce the adjustment and machining on site due to less interfaces. A wedge type support is also promising method to allow pre-assembly at factory and modular assembly on site so as to achieve precise assembly tolerance without adjustment and machining on site.

(4) Relative displacement at interfaces

Critical issues: The contact surfaces between key & key-ways, TF magnet & BC, and TF magnet & CS coil have to be flexible to allow relative displacement of CS coil and TF magnet: this requires perfect surface contact at the interfaces and bearing/sliding mechanism at the surfaces where high surface contact pressure over 100 MPa is applied.

Recommendations: It is recommended to decrease/prevent mutual interaction between TF magnet and CS coil.

Possible options: TF magnet with coil case around the winding pack can decrease the number of keys and surface contact pressure. A wedge type support is also promising method because of no mechanical interaction between TF magnet and CS coil.

(5) Installation of keys

Critical issues: Nose keys and lower triangular keys are installed between TF magnets for sustaining overturning forces: total number of keys is in the order of 10^4 as shown in Fig. 3.3.2, and they have to be installed uniformly without misalignment for several contact surfaces of each key at the same time. In particular, a number of lower triangular keys have to be fixed together as a integrated structure and extremely precise assembly is required: misalignment of some of contact surfaces causes less supporting capability, stress concentration or excessive deformation of TF magnet. In addition, disassembly of stick keys is impractical and access space for the lower keys is insufficient.

Recommendations: It is recommended to decrease the number of keys, to improve the key structure into simple configuration and to consider robust supports for assembly misalignment and gaps. A sensitivity analysis to define the allowable misalignment/gaps is also recommended to finalize specifications on the assembly tolerance of key installation.

Possible options: TF magnet with coil case around the winding pack can decrease the number of keys and provide robustness since the coil case is used for a stiff primary structure and keys as a supplementary structure.

Preliminary studies on key installation systems: Key installation systems for nose keys and lower keys have been investigated and the following systems are proposed as a possible option. Major problems are space requirements and assembly tolerance such as misalignment/gaps for keys installation. The assembly tolerance depends on fabrication

tolerance of keys and key-way and precision of dimension measurement and machining adjustment, and detailed evaluation including R&D is necessary. In the reality, misalignment/gaps is considerable and a FEM analysis to assure the structural integrity has to be conducted in order to clarify allowable misalignment/gaps in parallel with the design of the assembly system.

1) Option 1 : Nose keys installation

(a) Postulates and concepts

- TF coils are fixed in final position beforehand.
It is impractical to adjust/correct the position of TF magnets using keys: keys are just inserted into the key-way and TF magnets have to be placed on the final position in the radial and circumferential direction.
- Nose keys are aligned with adjustment mechanisms.
Nose keys are inserted and aligned with adjustable wedges by screwing up to uniform torque under the fixed position of TF magnets.
- Nose keys are supplied from a rack.
The whole nose keys in a sector are stored in the nose key rack after adjustment machining and supplied by a nose key insertion tool to the corresponding key-way: the nose key rack can be rotated toroidally and the key insertion tools can be moved vertically so as to adjust the position.
- The tips of nose keys are tapered for easy positioning.

(b) Tooling plan

a) Central column

A co-axial cylindrical structure is installed in the position of CS coil so as to measure/adjust/fix the position of TF magnets, as shown in Fig. 3.3.4. The inner column is to measure the position. The outer column is to adjust and fix the position using hydraulic jacks. The inner column is mechanically separated from the outer column so as to keep the reference surface correctly without interaction of mechanical loads acting on the outer column. The space for keys installation system is allocated between the cylindrical structure and the TF magnet nose surface, as shown in Fig. 3.3.3.

b) Keys installation system

The key installation system is composed of turn table, key rack and key insertion tool, as shown in Fig. 3.3.5. The turn table can be rotated toroidally and on which the key rack and insertion tools are set: the turn table can be arranged in the upward or downward as options. The nose key rack

contains a set of keys within the frames and can be moved vertically for adjusting the position to the respective key-way. The key insertion tool is composed of two nut-runners which has three degree of freedom; vertical, axial, and rolling.

(c) Nose keys installation scheme

- 1) Install the co-axial cylindrical column at the position of CS coil.
- 2) Install the TF/VV sub-assembly.
- 3) Adjust the position of TF coils. The radial position is adjusted by pulling/pushing the TF coils inward/outward with adjustable bolts or jacks set in the external cylindrical column until the nose of TF is placed in the final position: the position is measured using optical device set on the internal cylindrical column. The circumferential position is adjusted using transporter for TF with an assistance of local adjustable actuator such as jack.
- 4) Install spacers between MS and TF magnet or intercoil structure between TF magnets after the TF magnet is placed in the final position.
- 5) Insert and fix the nose keys into the key-ways in the opposite direction simultaneously using the key installation system installed in the space between the external cylindrical column and the TF magnet nose surface.
- 6) Repeat the key insertion/fixation circumferentially by turning the table and exchanging the key racks.
- 7) Remove the key installation system after the key insertion and fixation.
- 8) Remove the cylindrical column for installation of CS/BC sub-assembly.

2) Option 2 : Lower keys installation

The lower triangle keys requires to align several surfaces at the same time in order to have an integrated structure against the large electromagnetic forces. For this, adjusting wedges are to be inserted for the proper alignment between the triangular keys, and between the key-way and the triangular keys, as schematically shown in Fig. 3.3.2.

(a) Postulates and concepts

- TF magnets and VV are fixed in the final position beforehand.
- TF magnets are supported tightly in the radial/toroidal direction for preventing movements during the key installation.

(b) Lower key installation system

a) Setup

A sketch of lower key installation system is shown in Fig. 3.3.6. The whole lower keys are installed at the same time with hydraulic jacks. The jacks are set on a truck which can be operable along a rail system toroidally and has an elevation mechanism vertically.

b) Space requirements

Size of the lower key installation system composed of the tools and truck is about 6700H*8400L*350W (inside of torus) according to the preliminary study.. On the other hand, the space under the machine is limited as shown in Fig. 3.3.7, so that the lower space has to be increased twice in height.

(6) CS coil replacement

Critical issues: The present bucking concept requires to create a clearance at the interface between TF magnets and CS coil for assembly/replacement of CS/BC sub-assembly: the interface is composed of bladder with filling material based on epoxy and loading plate, and they are fixed or stick due to large electromagnetic loads generated by TF magnet and CS coil after the operation. In the present design, synchronous retracting of TF magnet for the CS coil installation is proposed but it seems to be impractical since all of TF magnets are fixed with keys and the TF retracting is not allowed: there is no space to retract the keys when the CS coil is in place. In addition, it seems questionable to warm all the magnet system over 180 °C in order to remove the epoxy-base filling material from the bladder.

Recommendations: It is recommended to assembly/replace the CS coil without the TF movement and to eliminate the interface structure such as bladder which gives assembly uncertainties and create complexity for assembly/disassembly. Sub-division of the CS/BC sub-assembly should be considered so as to reduce the weight down to the present lifting technology level (~ 1,300 ton).

Possible options:

1) Option 1 : Conical interface between CS coil and TF magnet

This concept can provide sufficient initial clearance between TF magnet and CS coil without TF retracting due to the tapered arrangement: TF magnet can be fixed in the final position before and during the CS installation. In addition, surface alignment at the interface between TF magnet and CS coil can be achieved using a liner/shim which is attached on the CS surface and replaceable for adjustment machining

according to the precise measurement of the TF nose surfaces alignment: no intermediate structure such as bladder is necessary. In case of sticking due to large electromagnetic loads, the CS/BC sub-assembly can be pushed from the bottom and thereafter the sub-assembly can be removed using overhead crane.

2) Option 2 : Wedge type support

In this concept, TF magnets are supported by wedges of TF coil cases independently from the CS supports and a clearance at the interface between them can be kept during assembly and operation. Thus, no mechanical interaction between CS coil and TF magnet, and CS coil can be replaced without TF movement.

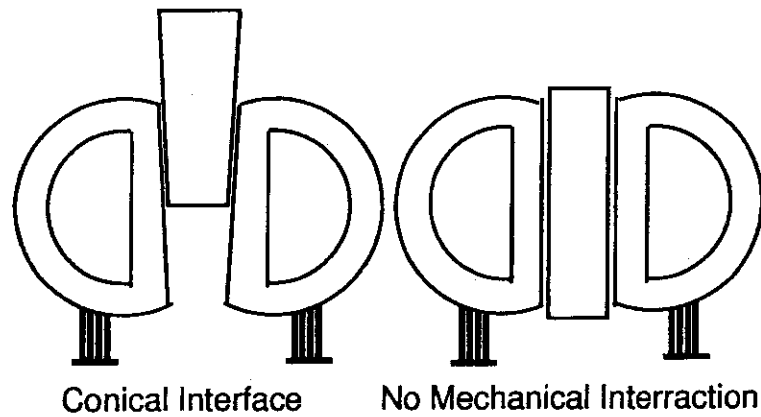

(7) Mechanical structure (MS) installation

Critical issues: In the present MS design and assembly procedure, MS is a cylindrical structure segmented into 6 sectors with a dead weight of around 1,000 ton/sector and installed in the final position before the TF magnet installation: MS covers all outer surfaces of TF magnet and prohibits the access to the tokamak core for maintenance/reassembly and the removal of vacuum vessel segments in the radial direction. In addition, a lateral clearance in the level of 30 mm at the interface between TF magnet and MS is required for the TF installation and the clearance has to be filled with stiff structure for sustaining the large out-of-plane forces after the TF installation. However, no access space for this fixation is available since MS prohibits all of the lateral access: a movable adjusting mechanism to fill the clearance is possible but low mechanical stiffness and assembly misalignment/gaps has to be taken into account.

Recommendations: It is recommended to divide MS structure into more sub-segments so as to reduce the handling weight, provide access space to the tokamak core, and eliminate the movable structure to fill the lateral clearance.

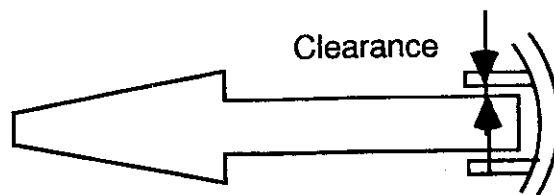

Possible options: An intercoil structure with sector configuration instead of the present MS design is a possible option. In this concept, the intercoil structure can be installed between TF magnets from the outside after the TF magnet fixed in the final position and the uniform surface contact at the interface can be achieved with machining of the intercoil structure surface. Thus, no movable mechanism to fill the lateral clearance is necessary. In addition, the intercoil structure is a sector configuration, resulting in reducing the handling weight and allowing the removal of TF magnet/vacuum vessel sector in the radial direction after intercoil structures in the sector are removed.

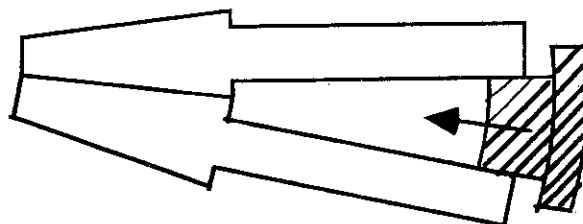

(8) Backing cylinder (BC)

Critical issues: The BC is segmented into 24 sectors and each sector is composed of 2 wedge module, 2 parallel module and a electrical insertion. This segmentation gives too many interfaces to be aligned and less mechanical stiffness for wedge type support due to different compliance between parallel and wedge modules.

Recommendations: It is recommended to reduce the number of modules and to increase the mechanical stiffness.

Possible options: Figure 3.3.8 shows a possible segmentation obtained in the preliminary design study. In this option, 6 parallel modules partially wedged and 18 wedge modules are arranged circumferentially and 2 types of supplementary wedges (Wedge-A & B) are inserted between modules for their final fixation. This option is fully compatible with the assembly scheme without interaction of the CS coil joints.

(a) Proposed segmentation

BC is basically divided into 24 main wedge pieces. These consist of 6 types of 4 main pieces and 2 types of 8 supplementary wedges..

The supplementary wedges are installed from the center of torus, and always push the BC toward TF magnet.

A main piece (P) shown in Fig. 3.3.8 is parallel module but partially wedged. This module provides the space for disassembly without circumferential movement. A wedge-A are inserted on both side of this module in order to keep the wedge effect.

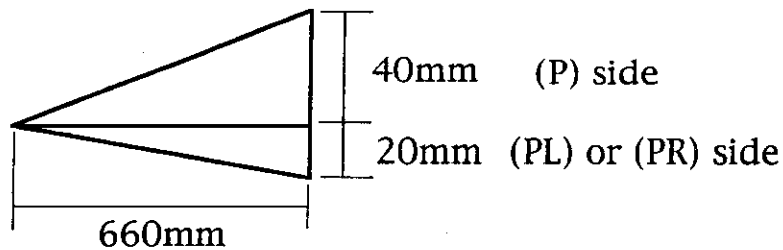

Main pieces (PL) and (PR) shown in Fig. 3.3.8 are adjoining modules to (P). (P) sides of these modules are fixed with the wedge-A mentioned above, and other sides are fixed with wedge-B for their final fixation.

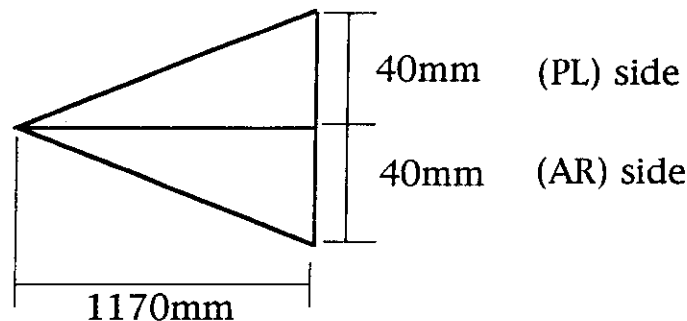

Main pieces (A), (AR) and (AL) shown in Fig. 3.3.8 are simple wedge configuration without necessity of wedges. Pieces (AL) and (AR) are adjoining modules to (A). (PL) or (PR) sides of these modules are fixed with the wedges mentioned above.

(b) Disassembly scheme

Typical disassembly scheme without interaction to the CS coil terminals/joints is as follows. Assembly of BC is the reverse order of this scheme.

- 1) Remove whole wedge-B
- 2) Remove whole wedge-A
- 3) Remove (P) to the center
- 4) Remove (PL) along with (AR) side wall to the center
- 5) Remove (PR) along with (AL) side wall to the center
- 6) Remove (AR) along with (A) side wall to the center
- 7) Remove (AL) along with (A) side wall to the center
- 8) Repeat 3) to 7) in 3 times
- 9) Remove (A)

(c) Tooling plan

A sketch of tool to insert the wedges-A & B during BC installation is schematically shown in Figs. 3.3.9.

Adjustment/fixing systems of lower/upper link of BC are also shown in Figs. 3.3.10 and 3.3.11, respectively.

(9) Lower PF coil assembly/maintenance

Critical issues: The lower PF magnets are supported with link type supports, which are composed of saddle-shaped link, L-shaped link, U-shaped link and triangle link, as shown in Figs. 3.3.12 ~ 3.3.15. The link type support is tight together with pins. Major problems are alignment requirements for pin insertion and available space for remote handling systems to install pins and handle the heavy link module.

Recommendations: It is recommended to improve the structural design of link type support so as to allow independent maintenance of the lower PF magnets, provide more working space and to allow simple remote maintenance.

Investigations: Disassembling scheme of lower links

A CAD investigation for disassembly of lower link structures for lower PF coil supports is shown in Figs. 3.3.12~3.3.16.

Fig. 3.3.16(a) shows disassembly of triangular link. Work space for pulling out the pin is absolutely narrow at PF 7 side. This space is only 473 mm wide though the pin length is 407 mm. The working space is at most 70 mm, and it is unfeasible to handling these pins remotely. The space of another side, between next link and itself, is useless because it is only 80 mm. The length of pins connecting triangular link and U link at PF 6 is about 1300 mm, and the work space is only 1280 mm. Thus the connection part of triangular link is to be divided into 2 pieces and length of the pin is reduced to be 500 mm.

3.4 In-vessel structures assembly

(1) Pin installation

Critical issues: Blanket modules are supported with link/pin joint to the vacuum vessel behind the back wall of blanket module. The link/pin joint has both to sustain the dead weight of blanket module and electromagnetic loads during disruption and to provide flexibility in the radial direction for thermal deformation. For this purpose, extremely fine alignment is required not only for pin insertion to the hole but also for angle adjustment of pin to the machine axis for allowing radial movement of blanket module. In addition, the space for pin installation and access to the joint location is insufficient as shown in Fig. 3.4.1.

Moreover, link/pin joint is not compatible with the back wall welding/cutting of blanket module since pin will be stuck due to welding deformation and can not produce the locking/positioning force for the back wall welding/cutting. Furthermore, a combination of link/pin joints limits the radial flexibility because of different rotating movement due to different link length: the vacuum vessel is connected to the 4-K structure through two link/pin joints which have different radial flexibility for thermal deformation, resulting in high thermal stress acting on one of link/pin joint.

Recommendations: It is recommended to consider alternate support concept instead of link/pin so as to allow practical alignment in remote operation, to be compatible with welding/cutting, and to provide the radial flexibility without kinematics.

Possible options: A movable cotter with metallic balloon is a possible option for the blanket supports to provide locking/positioning function for the welding/cutting, to allow welding deformation, to be compatible with remote operation, and to provide radial flexibility in sliding mechanism.(Fig. 3.4.2)

(2) Back-wall connection of blanket module

Critical issues: Severe gap control including position/posture control of blanket modules is required simultaneously to form toroidally continuous ring. Available space for access to the connection is very restricted. The present first wall (F/W) structure is too weak to support welding/cutting equipments and guide structures. Extremely small welding deformation is requested so as to assure the alignment of F/W.

Recommendations: It is recommended to increase clearance for access of the welding/cutting equipment to the connection and to improve the F/W structure be compatible with welding deformation.

Possible options: Two-side access welding from the front/back of the wall is a possible option to reduce the welding deformation: for this, the gap between the blanket back-wall and vacuum vessel should be more than 100 mm. A separated F/W is also promising concept to assure the required surface alignment of F/W and to provide the rigid guide structure for welding/cutting since it can be installed and adjusted after the welding/cutting.

(3) In-vessel assembly

Critical issues: The present design requires in-vessel transporters and manipulators for handling small canister, for repairing armor and for

viewing/inspection. The horizontal port opening for access of in-vessel transporters and manipulators is so restricted.

Recommendations: It is recommended to sub-divide the in-vessel components to be handled by the in-vessel transporter so as to reduce the handling weight down to 1 ton. To increase the port opening is also recommended.

Possible options: A rail-mounted vehicle is a possible option for a in-vessel transporter, which can be used as a common transporter system capable for wide-range in-vessel assembly/maintenance of armor, limiter, small canister, RF antenna, blanket back-wall connection, vacuum vessel field joint and in-vessel viewing/inspection: in this system, various in-vessel manipulators with end-effectors can be operable on a common rail at the same time effectively. Figure 3.4.3 shows the rail-mounted vehicle system compatible with the ITER EDA machine layout. This system is designed to have multi-degree of freedom including two types of rotating mechanism and telescopic manipulator and thus can be deployed through the narrow horizontal port into the vacuum vessel, as schematically shown in Fig. 3.4.4, but more clearance of around 20 mm in each side is requested. This system can handle at least 1-ton payload and be accessed to all surface of in-vessel components, as shown in Figs. 3.4.5~3.4.8.

3.5 Port arrangement and in-vessel components handling

The present design concept is based on 24-TF coil so as to reduce a toroidal ripple loss, resulting in limited port opening for handling the in-vessel components such as blanket and divertor.

(1) Upper port for blanket handling

Critical issues: Blanket modules have to be replaced through the upper vertical port and the available clearance between module and port wall is in the order of 20 mm which is insufficient for handling heavy and asymmetric structure with complex tilting motion balanced with counter weight, as shown in Figs. 3.5.1 and 3.5.2. In addition, the interfacing space between the port and the maintenance cask is too small for connecting/disconnecting the cask.

Recommendations: It is recommended to increase the port space so as to allow sufficient clearance over 100 mm between the blanket module and the port wall and to provide space for installing sub-manipulator for posture control of the blanket module. Furthermore, the extension of the upper port through cryostat lid is recommended to provide the

interfacing space for connecting and disconnecting the cask with double seal containment.

Possible options: Sufficient port space can be expected by reducing the number of TF magnet from 24 down to 18 according to the preliminary investigation based on the present segmentation. In addition, the port extension with trapezoidal cross-section provides adequate procedure to mount/dismount the cask with double seal door.

(2) Horizontal port for blanket test module handling

Critical issues: Blanket test modules are planned to be replaced through the horizontal port: this requires complex 3-D motion including rotation as shown in Fig. 3.5.3, and the horizontal port space allocated is insufficient according to the present segmentation of the module. In addition, the gripping location is limited to the top part of the module and thus stiff structure to sustain the reaction force has to be prepared: the present port structure is flexible due to bellows connection and the reinforcement is required.

Recommendations: It is recommended to reconsider the module segmentation so as to reduce the size and the weight and to enable the removal in simple motion through the horizontal port.

Possible options: A test module with the same size as the cross-section of the port opening is a possible option to meet the assembly and disassembly requirements. Another option is to remove the module through the upper vertical port.

(3) Pumping duct for divertor cassette handling

Critical issues: Because of the restricted space of the pumping duct, it is not feasible to move the cassette with multi-degree of freedom or to apply a large force for lifting the cassette. The cassette movements along the three-dimensional surface of the vacuum vessel is unstable, since the cassette a like a thin and tall wall configuration. There is interference of cooling pipe with the pumping duct wall in the present pipe arrangement during cassette handling: this also requires large cask for storing the cassette and long-length cooling pipe.

Recommendations: It is recommended to increase the duct opening space and to improve the cassette configuration so as to allow simple straight motions through the pumping duct. In addition, the divertor cooling pipes should be designed as a straight, circular and single configuration and the welding/cutting position located near the cassette.

Possible options: A sufficient port space can be obtained by reducing the number of TF magnet from 24 down to 18 according to the preliminary CAD investigation. A divertor cassette concept, as schematically shown in Figs. 3.5.4 and 3.5.5, is a possible option for the divertor maintenance through the pumping duct. Major features of this proposed concept are as follows:

- 1) The cassettes are fixed horizontally on the structure floor and the movement is horizontal without complex motions. The cooling pipe is cut/welded near the cassette.
- 2) The cassette of center and side modules can be moved in the radial and toroidal direction respectively using rollers installed on the bottom surface of the cassette.
- 3) After retracting the center module radially by an external driving device inserted through the duct, a truck is inserted to draw/extract the side module.
- 4) Dovetail grooves or rails on the vacuum vessel surface are to guide the rollers during the side module movement in the toroidal direction.
- 5) The cassettes can be carried with simple movement of the truck in the toroidal and radial direction without lifting.

4. Recommended Assembly Procedure

Based on the preliminary investigation on assembly/maintenance procedure taking into account the overall design approach and remote operation perspective, the following procedures are recommended for the ITER main components assembly. Many of the assembly procedures are to be the same as that of maintenance and common tools are used as much as possible.

4.1 Construct cryostat

Bottom end-plate and side wall of the cryostat are constructed in the reactor hall. The local leak tightness is tested in a masking method. The lower base is installed on the bottom end-plate of cryostat.

4.2 Install gravity supports

The gravity supports for TF magnets and vacuum vessel are installed in the final position on the base. Temporary cylindrical support for measurements and adjustment of TF magnet position is installed on the base.

4.3 Place lower PF coils

PF coils 5,6,7 are placed on the base temporarily through assembly/maintenance tunnel located under the machine.

Possible options: A sufficient port space can be obtained by reducing the number of TF magnet from 24 down to 18 according to the preliminary CAD investigation. A divertor cassette concept, as schematically shown in Figs. 3.5.4 and 3.5.5, is a possible option for the divertor maintenance through the pumping duct. Major features of this proposed concept are as follows:

- 1) The cassettes are fixed horizontally on the structure floor and the movement is horizontal without complex motions. The cooling pipe is cut/welded near the cassette.
- 2) The cassette of center and side modules can be moved in the radial and toroidal direction respectively using rollers installed on the bottom surface of the cassette.
- 3) After retracting the center module radially by an external driving device inserted through the duct, a truck is inserted to draw/extract the side module.
- 4) Dovetail grooves or rails on the vacuum vessel surface are to guide the rollers during the side module movement in the toroidal direction.
- 5) The cassettes can be carried with simple movement of the truck in the toroidal and radial direction without lifting.

4. Recommended Assembly Procedure

Based on the preliminary investigation on assembly/maintenance procedure taking into account the overall design approach and remote operation perspective, the following procedures are recommended for the ITER main components assembly. Many of the assembly procedures are to be the same as that of maintenance and common tools are used as much as possible.

4.1 Construct cryostat

Bottom end-plate and side wall of the cryostat are constructed in the reactor hall. The local leak tightness is tested in a masking method. The lower base is installed on the bottom end-plate of cryostat.

4.2 Install gravity supports

The gravity supports for TF magnets and vacuum vessel are installed in the final position on the base. Temporary cylindrical support for measurements and adjustment of TF magnet position is installed on the base.

4.3 Place lower PF coils

PF coils 5,6,7 are placed on the base temporarily through assembly/maintenance tunnel located under the machine.

4.4 Install TF with VV parallel module

A TF magnet with parallel module of vacuum vessel (VV) is installed on the TF gravity support in the final position using the temporary central cylinder. All of TF and parallel module of vacuum vessel is installed in the same procedure.

4.5 Install VV wedge module

A VV wedge module with port base is installed on the VV gravity support and temporarily welded to the VV parallel module in the final position.

4.6 Assemble mechanical structure

Intercoil structures are installed between TF magnets and fixed in the final position after alignment adjustment.

4.7 Fix TF coils with keys

Nose keys are installed from the CS coil side and fixed in the final position. Upper and lower keys are installed and fixed.

4.8 Install CS coil

After removal of the temporary central cylinder, CS coil is installed from the top and fixed in the final position with connecting structures to TF magnets.

4.9 Install PF coils

PF coils 5,6,7 are installed and fixed in the final position. PF 2, 3 and 4 coils are installed from the top and fixed in the final position.

4.10 Connect magnet termination and service lines

Current termination and cooling pipes of all of magnets are connected to the power supply, protection, data acquisition and cryogenic systems. Cryostat upper lid is installed and all of port penetrations are covered with temporary flanges. The leak tightness of the cryostat is tested.

4.11 Magnet performance test

Whole magnet system is charged up to their rated current in according to the ITER operation scenario.

4.12 Weld VV sectors

After the magnet performance test, the cryostat upper lid and temporary flanges are removed. VV parallel and wedge modules are fully welded and the leak tightness is tested.

4.13 Weld VV ports

Port extensions of upper vertical , horizontal and pumping duct are installed through the cryostat port opening and connected by welding to the VV port base and the cryostat port base. Bellows are connected by welding to the port extensions and the leak tightness is tested.

4.14 Install in-vessel components

All of in-vessel components are installed through port opening and fixed in their final position.

5. Conclusions

Preliminary design studies on assembly/maintenance plan of the ITER main components have been conducted. Critical issues obtained through the studies and the proposed design improvements and possible options are summarized in this report. Many of the critical issues are caused from the present structural design and machine layout. Therefore, in order to develop the assembly/maintenance procedure, technological assessment concerning these issues is to be made and possible improvements have to be clarified through quantitative investigations for the further engineering design. As a whole, ITER requires unprecedented remote operations in scale, complexity and environments, and thus extensive technology development including mock-ups demonstration must be performed in EDA so as to bridge the technology gap between the present level and the required one, and to develop the structural design and machine layout compatible with remote operation.

Acknowledgement

The authors would like to express their sincere appreciation to Drs. S. Shimamoto and S. Matsuda for their continuous guidance and encouragement. They also would like to acknowledge Toshiba Corp. and all of other members who supported this work.

4.13 Weld VV ports

Port extensions of upper vertical , horizontal and pumping duct are installed through the cryostat port opening and connected by welding to the VV port base and the cryostat port base. Bellows are connected by welding to the port extensions and the leak tightness is tested.

4.14 Install in-vessel components

All of in-vessel components are installed through port opening and fixed in their final position.

5. Conclusions

Preliminary design studies on assembly/maintenance plan of the ITER main components have been conducted. Critical issues obtained through the studies and the proposed design improvements and possible options are summarized in this report. Many of the critical issues are caused from the present structural design and machine layout. Therefore, in order to develop the assembly/maintenance procedure, technological assessment concerning these issues is to be made and possible improvements have to be clarified through quantitative investigations for the further engineering design. As a whole, ITER requires unprecedented remote operations in scale, complexity and environments, and thus extensive technology development including mock-ups demonstration must be performed in EDA so as to bridge the technology gap between the present level and the required one, and to develop the structural design and machine layout compatible with remote operation.

Acknowledgement

The authors would like to express their sincere appreciation to Drs. S. Shimamoto and S. Matsuda for their continuous guidance and encouragement. They also would like to acknowledge Toshiba Corp. and all of other members who supported this work.

4.13 Weld VV ports

Port extensions of upper vertical , horizontal and pumping duct are installed through the cryostat port opening and connected by welding to the VV port base and the cryostat port base. Bellows are connected by welding to the port extensions and the leak tightness is tested.

4.14 Install in-vessel components

All of in-vessel components are installed through port opening and fixed in their final position.

5. Conclusions

Preliminary design studies on assembly/maintenance plan of the ITER main components have been conducted. Critical issues obtained through the studies and the proposed design improvements and possible options are summarized in this report. Many of the critical issues are caused from the present structural design and machine layout. Therefore, in order to develop the assembly/maintenance procedure, technological assessment concerning these issues is to be made and possible improvements have to be clarified through quantitative investigations for the further engineering design. As a whole, ITER requires unprecedented remote operations in scale, complexity and environments, and thus extensive technology development including mock-ups demonstration must be performed in EDA so as to bridge the technology gap between the present level and the required one, and to develop the structural design and machine layout compatible with remote operation.

Acknowledgement

The authors would like to express their sincere appreciation to Drs. S. Shimamoto and S. Matsuda for their continuous guidance and encouragement. They also would like to acknowledge Toshiba Corp. and all of other members who supported this work.

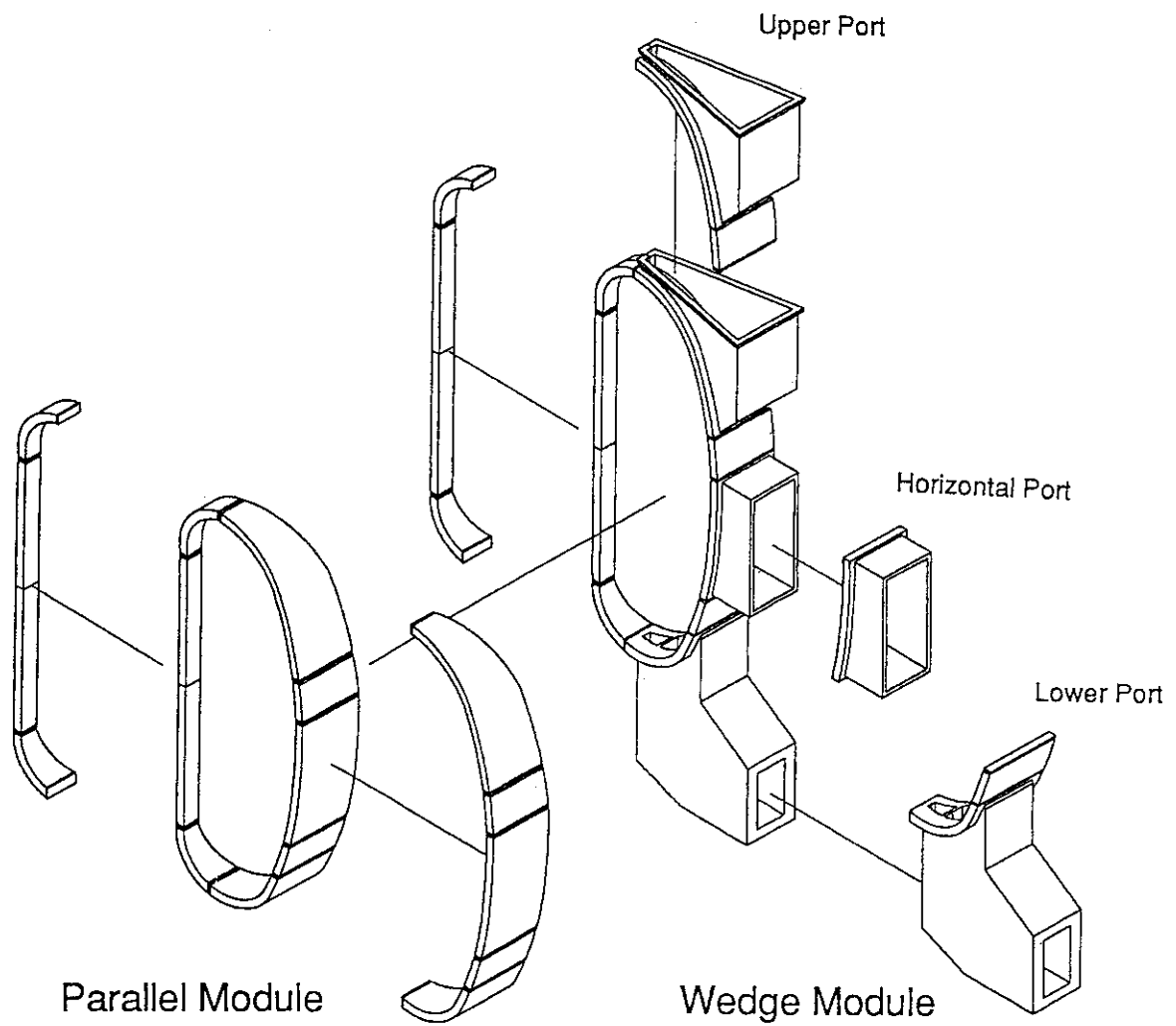

Fig. 3.1.1(a) Example of vacuum vessel segmentation

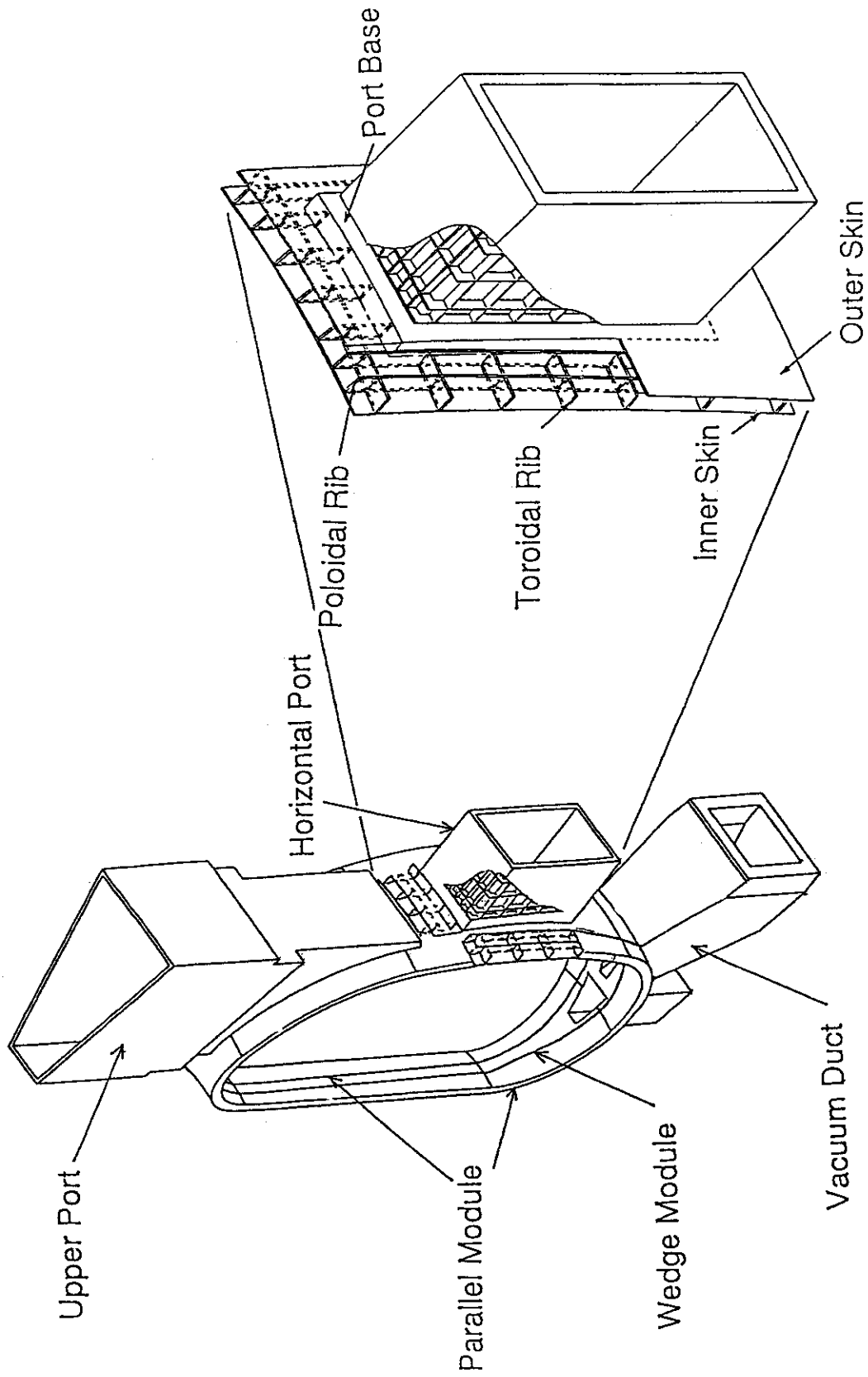
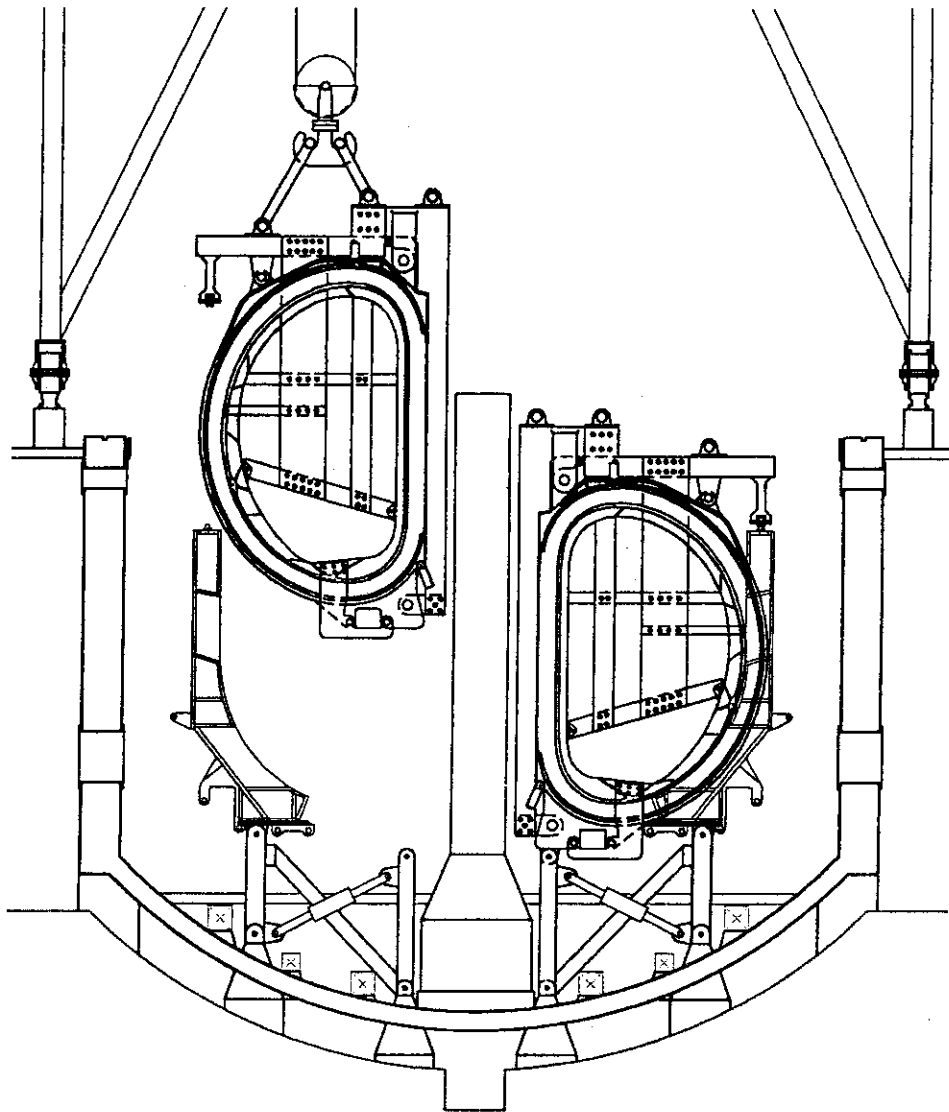

Fig. 3.1.1(b) Example of port connection with port base



NOTE:
TF Coil and Vacuum Vessel are supported independently.



Fig. 3.1.2 TF/VV SUBASSEMBLY INSTALLATION

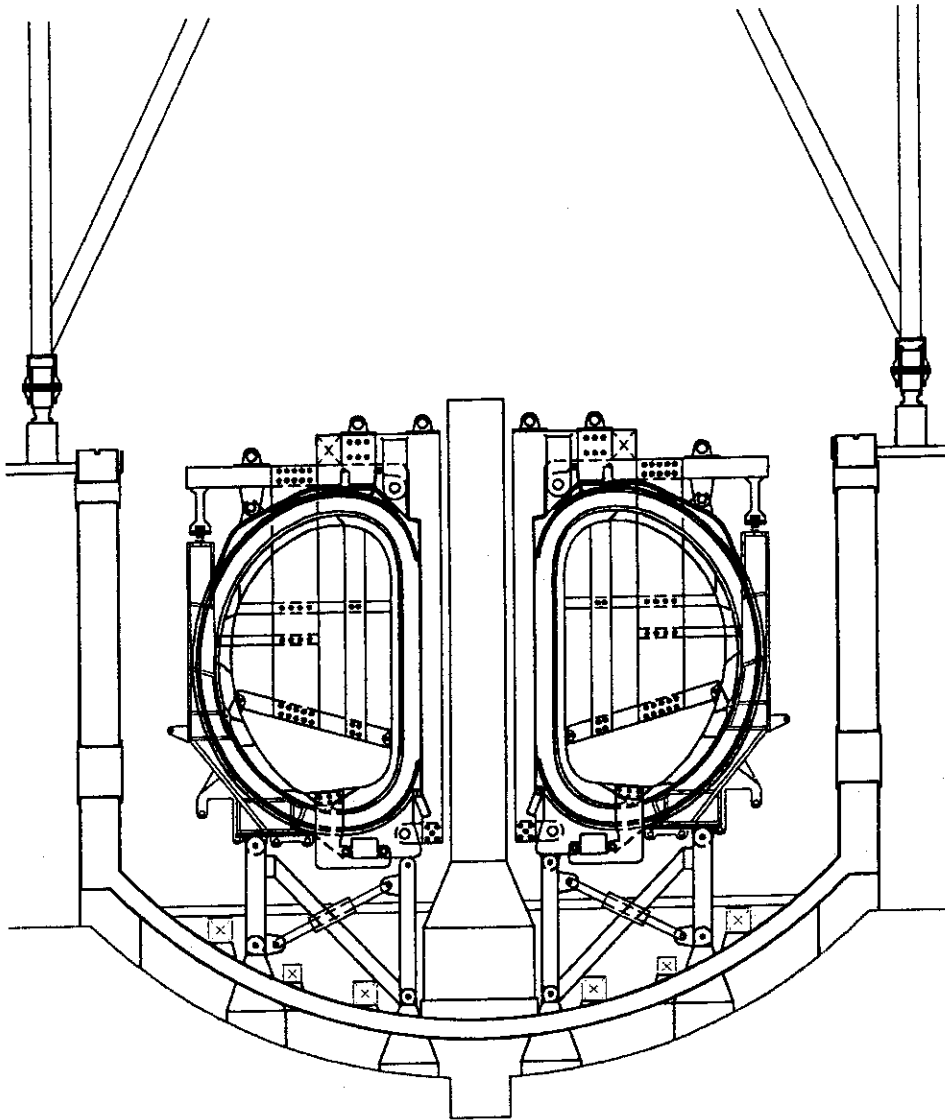

NOTE:
TF Coil and Vacuum Vessel are supported independently.

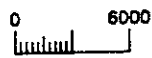
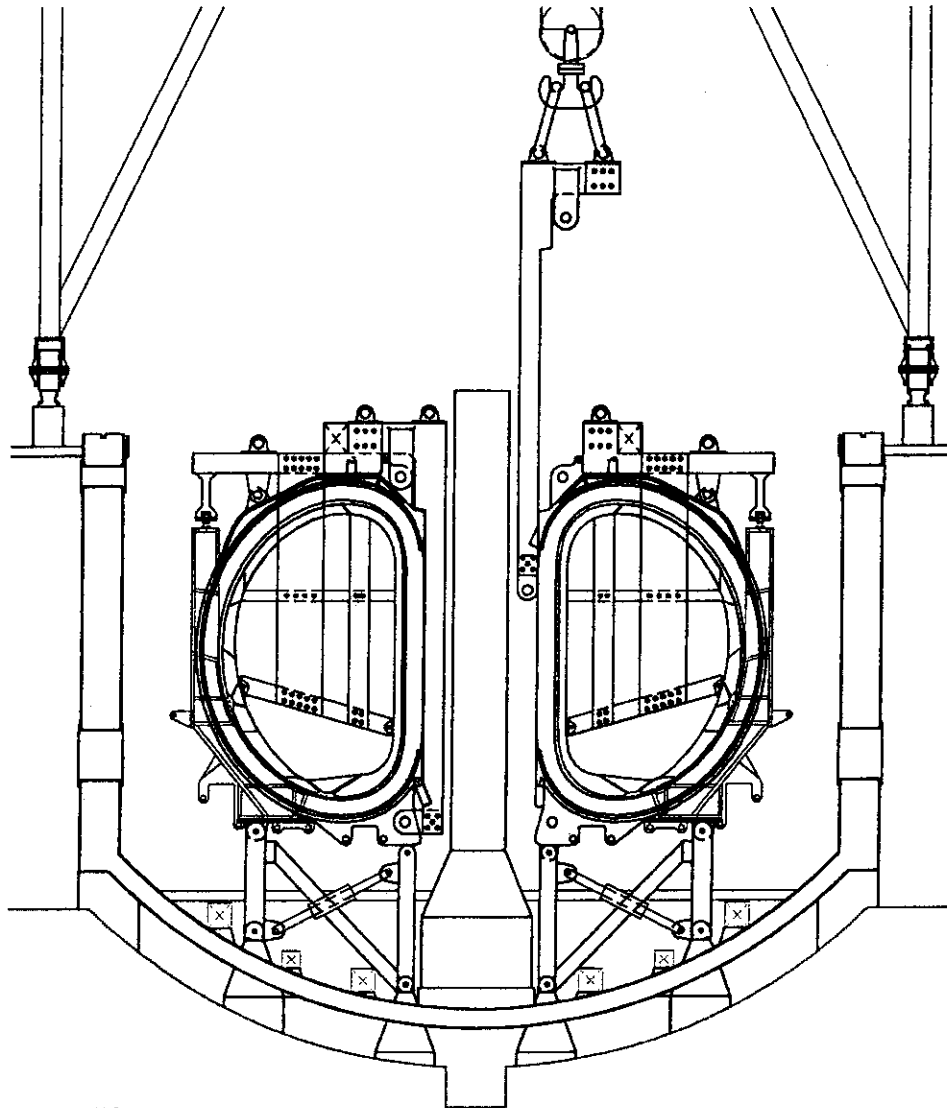

Fig. 3.1.3 RING STRUCTURE INSTALLATION



NOTE:
*TF Coil and Vacuum Vessel are supported independently.
Horizontal Beam and Lower Bracket already removed*



Fig. 3.1.4 VERTICAL BEAM REMOVAL

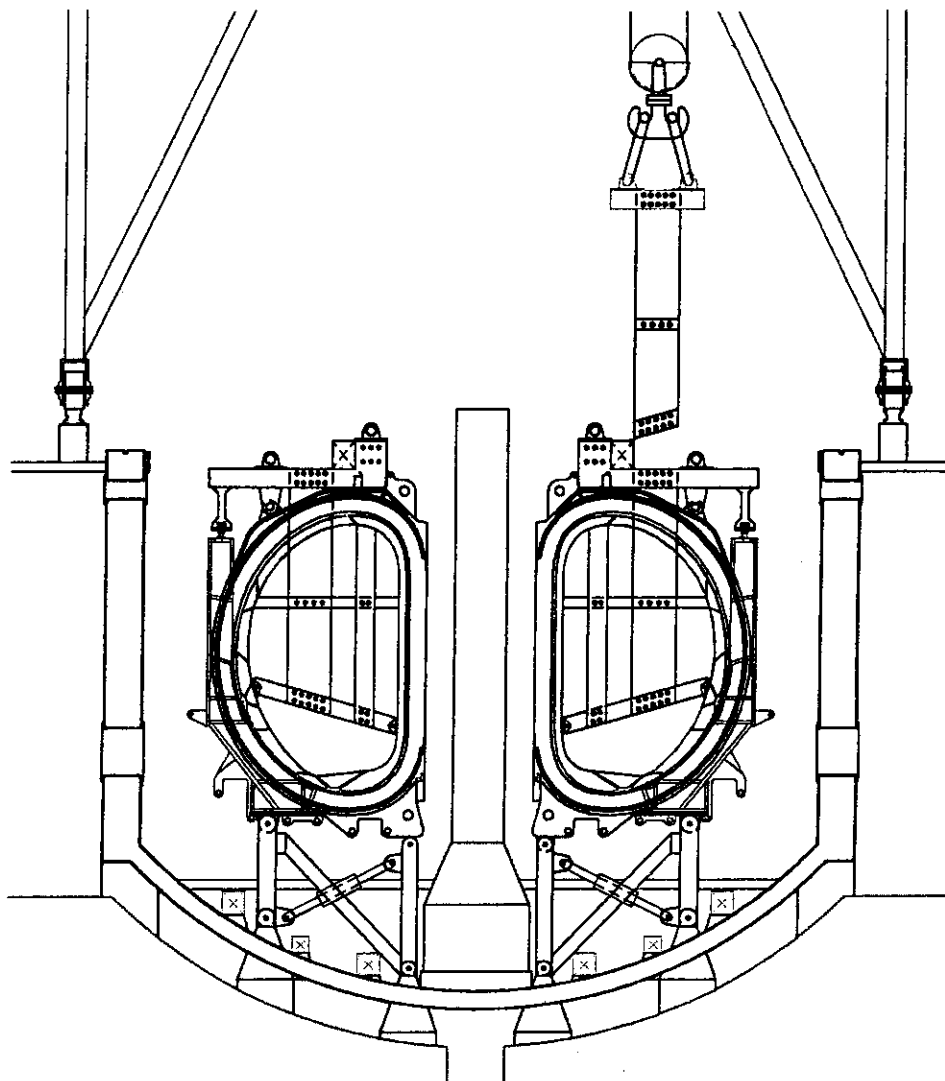

NOTE:
TF Coil and Vacuum Vessel are supported independently.

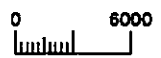

Fig. 3.1.5 VACUUM VESSEL INTERNAL SUPPORT REMOVAL

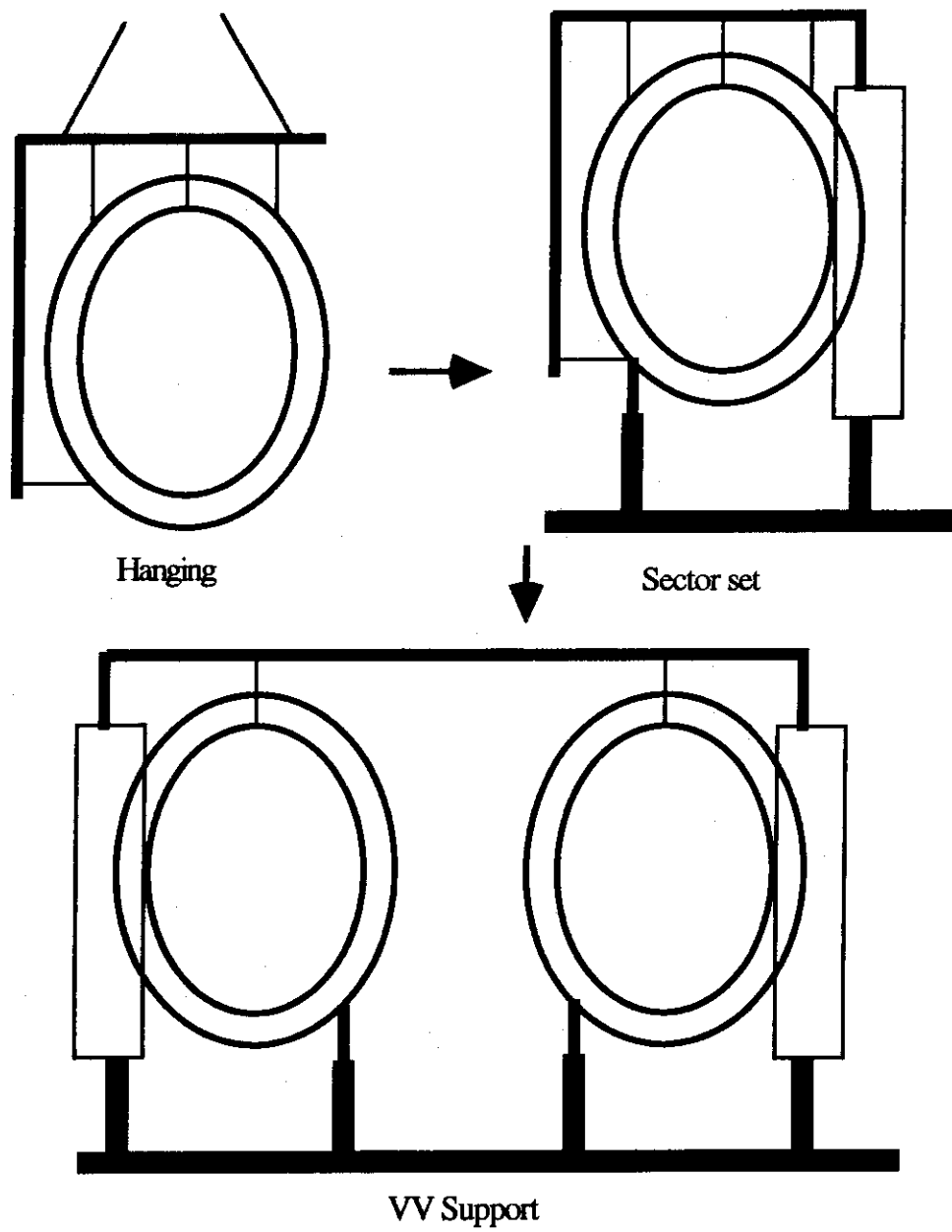

Fig. 3.1.6 Schematic Model of Support Concept

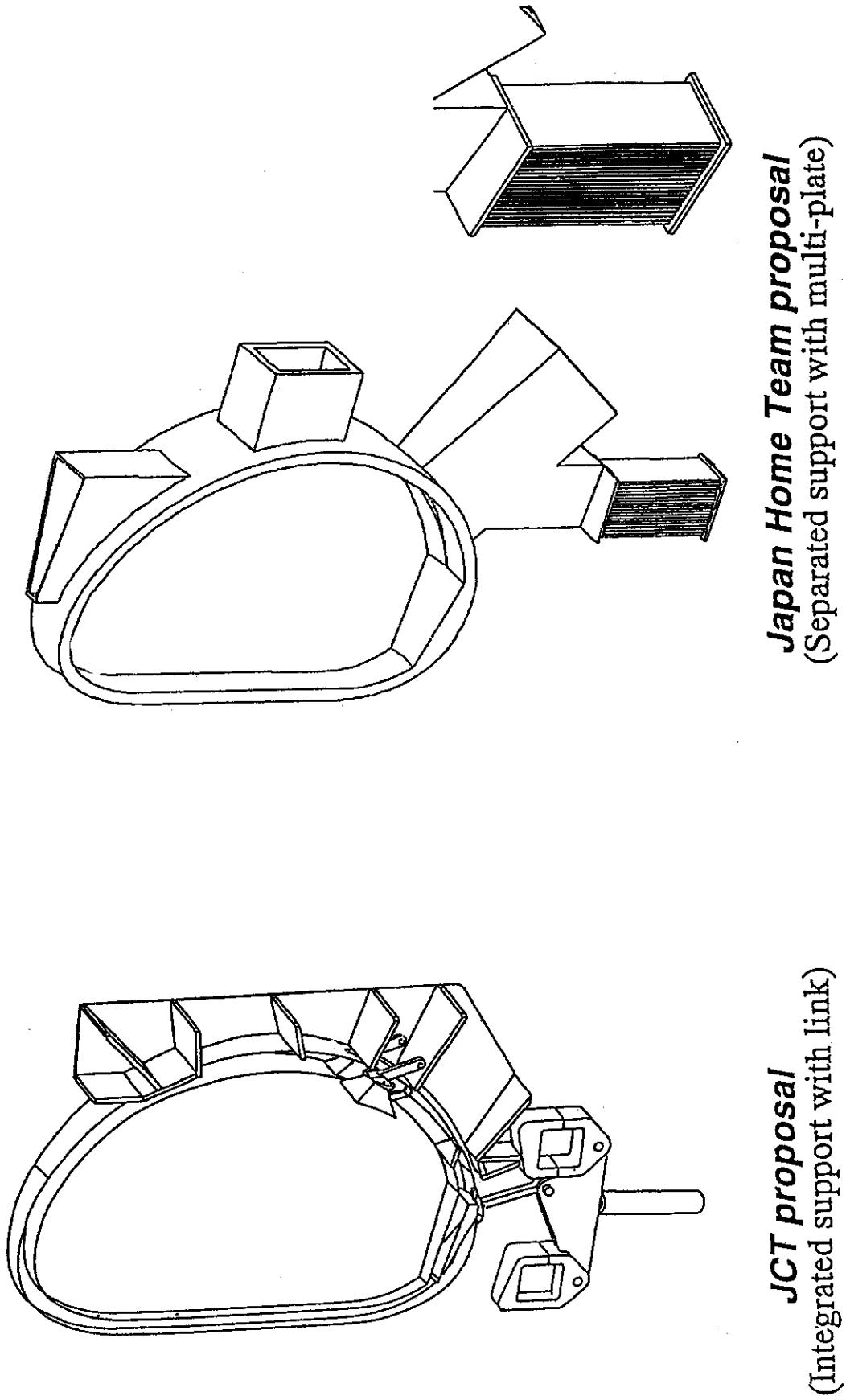

Fig. 3.2.1 Concept of vacuum vessel support

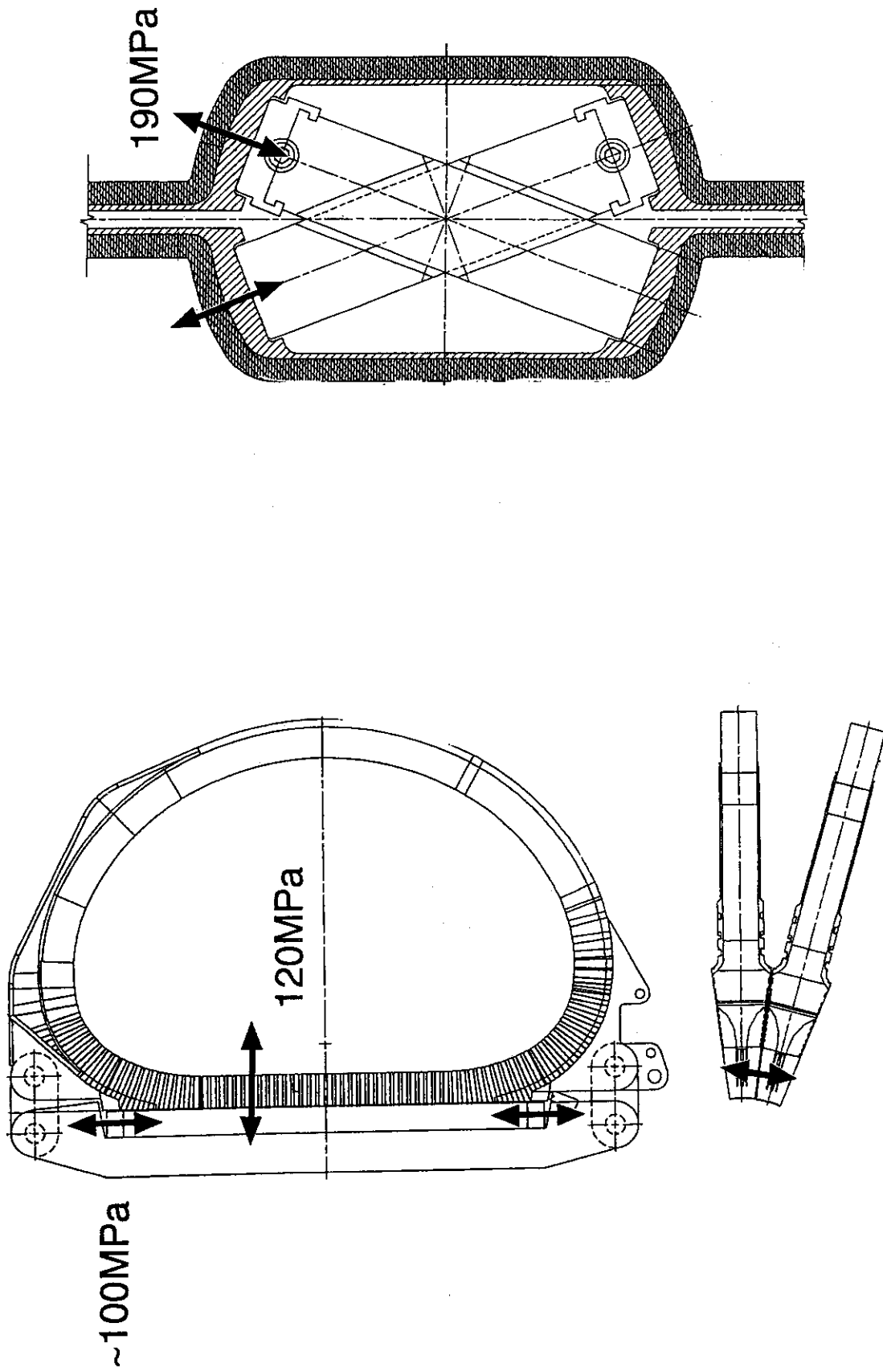
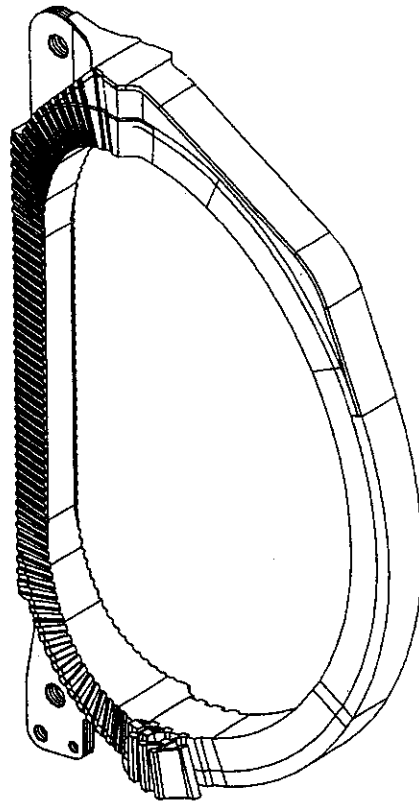
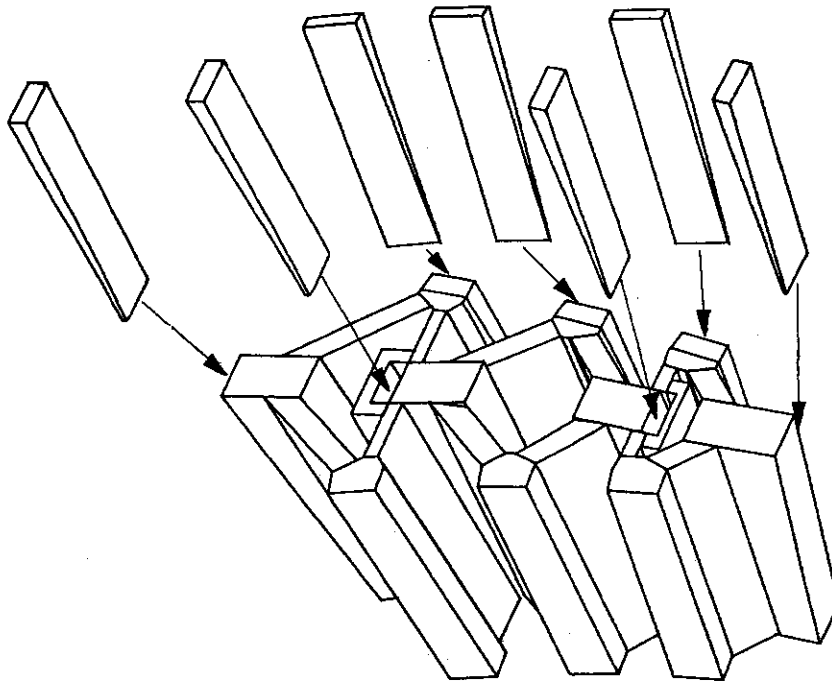

Fig. 3.3.1 Force transmission through interfaces



Nose keys and lower keys : $75 \times 24 \times 4 = 7200$



Keys for lower keys

Fig. 3.3.2 Number of keys

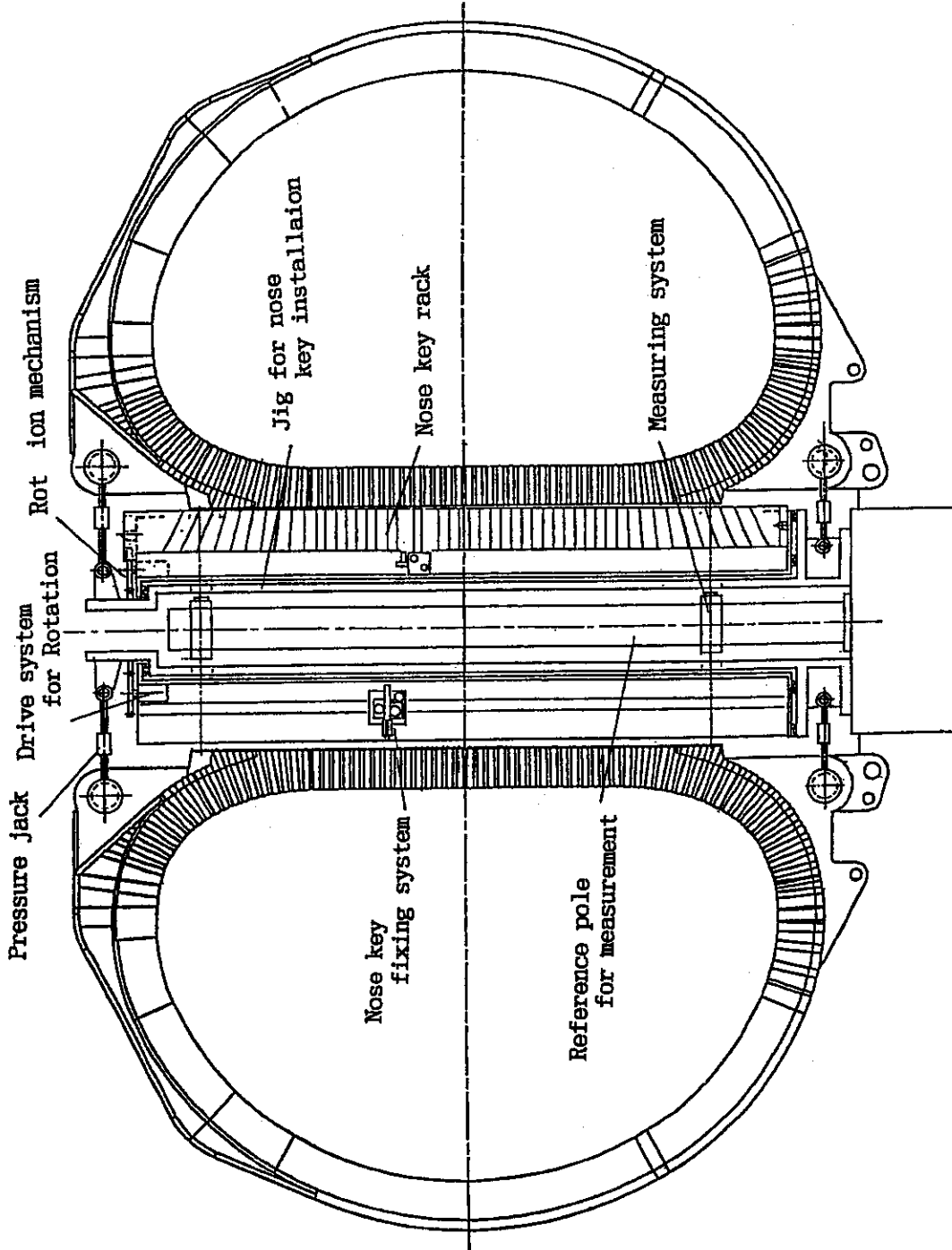

Fig. 3.3.3 Plan view of nose key installation system

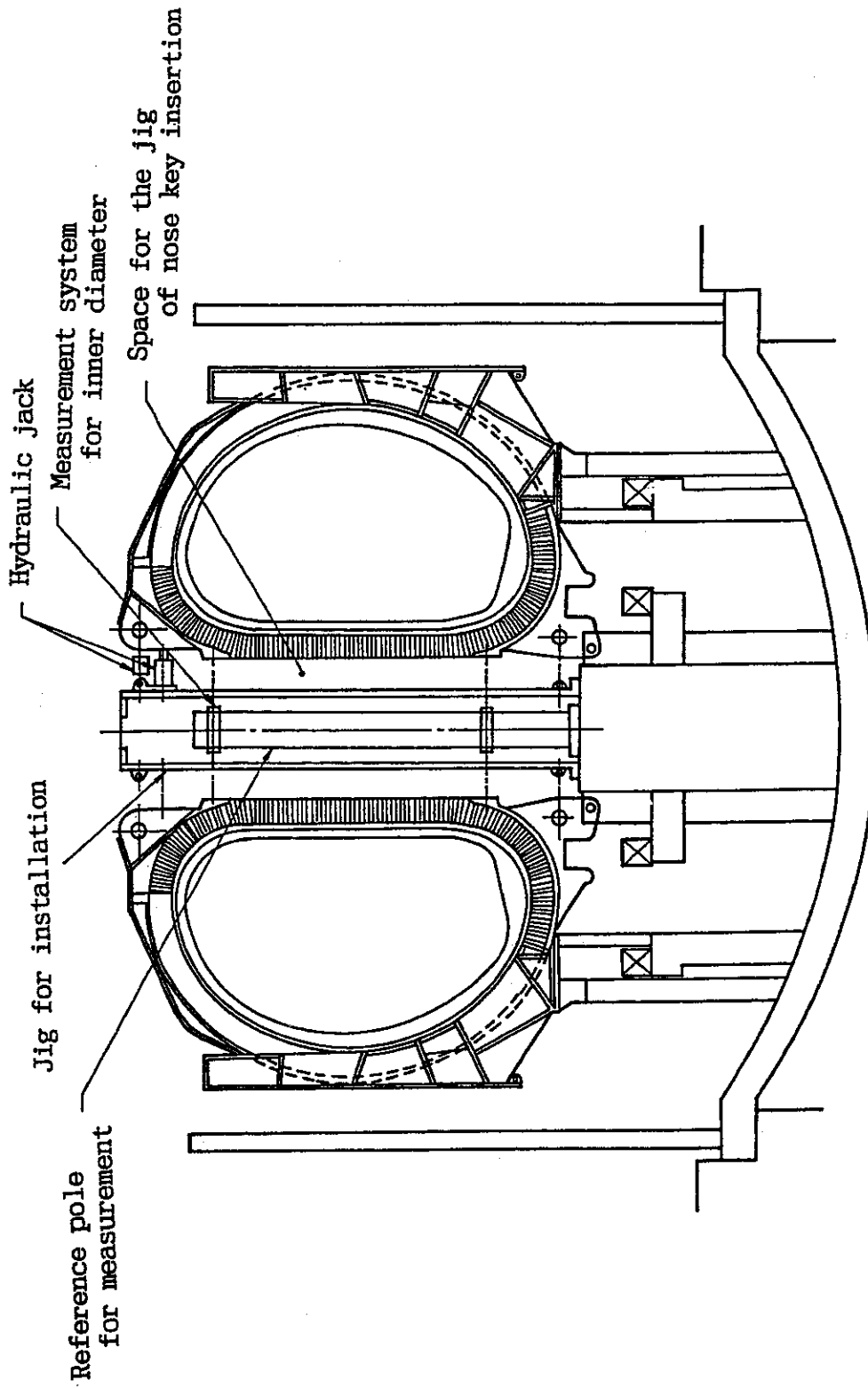

Fig. 3.3.4 Temporary central fixture for measurement/adjustment of TF magnets

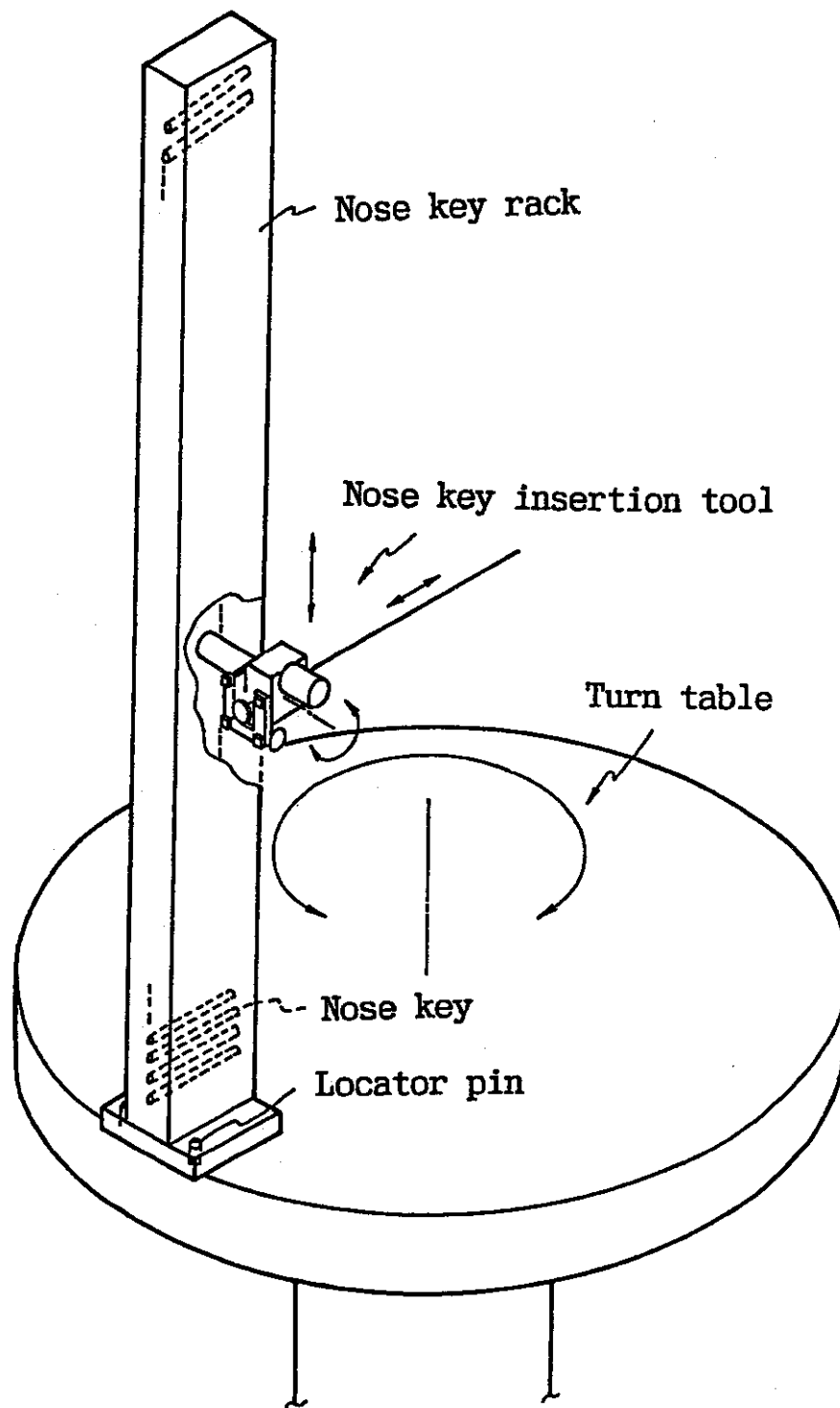

Fig. 3.3.5(a) Nose key insertion system

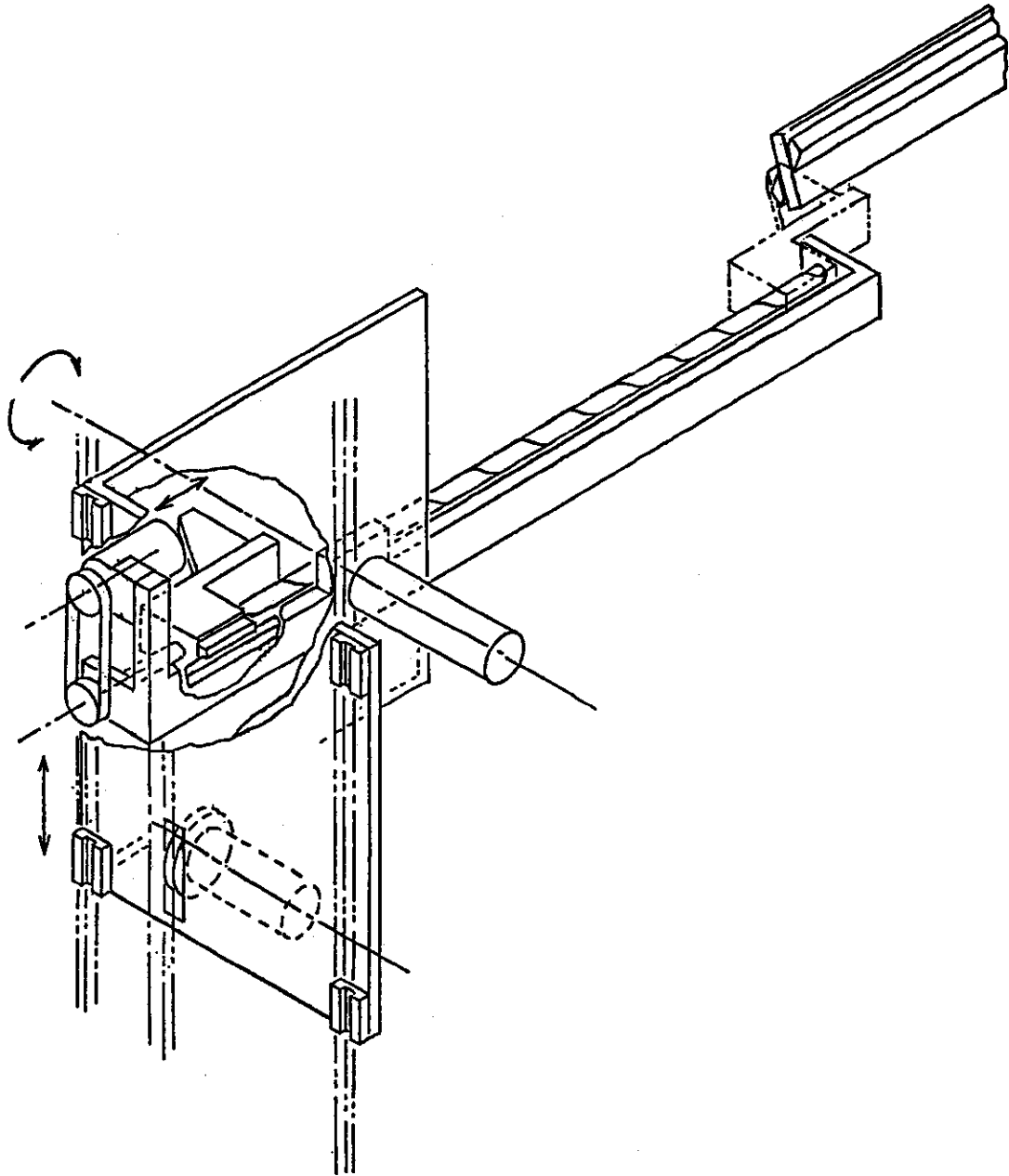

Fig. 3.3.5(b) Details of key adjustment tool

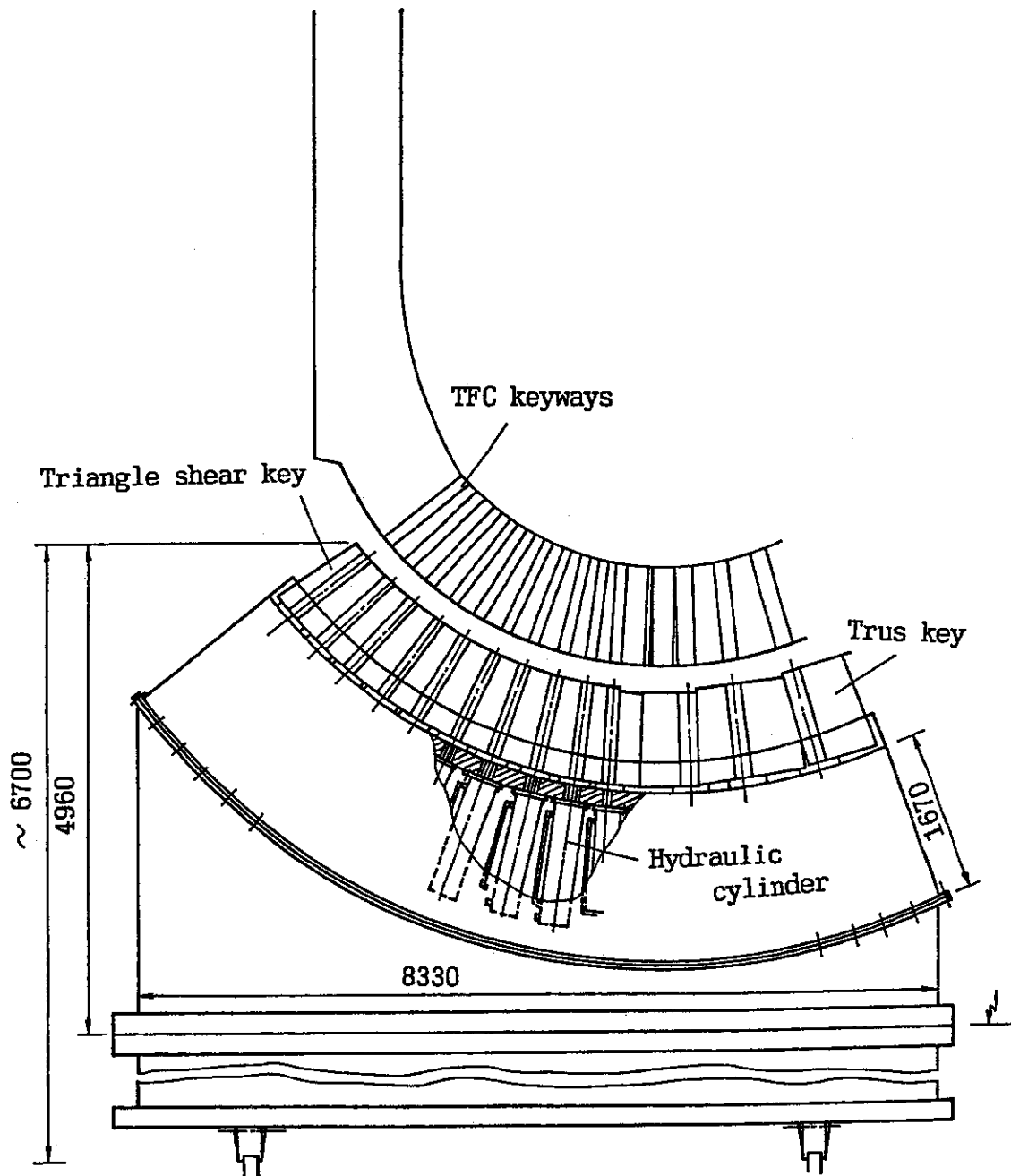

Fig. 3.3.6 Lower key installation system

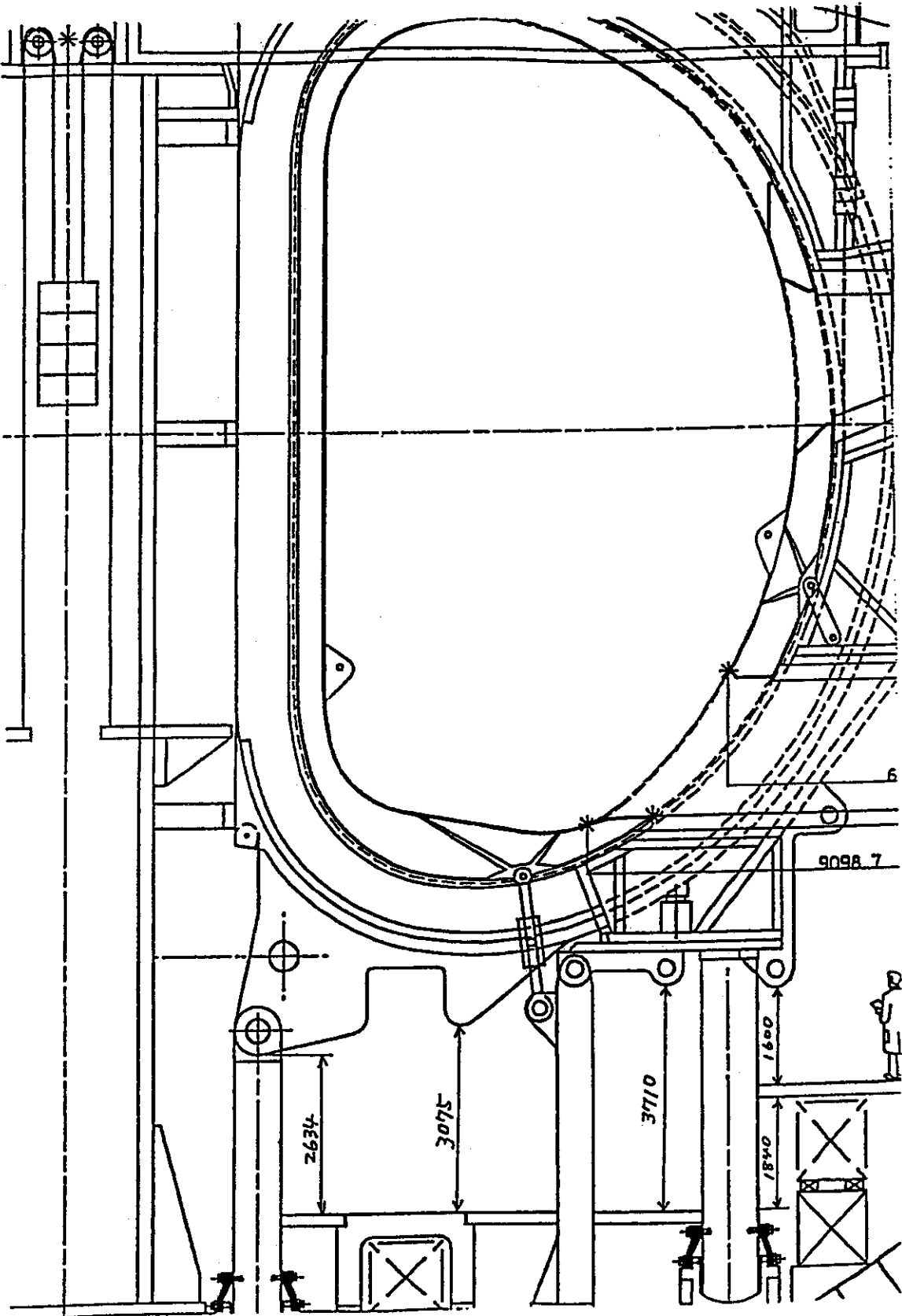

Fig. 3.3.7 Working space under the TF coil

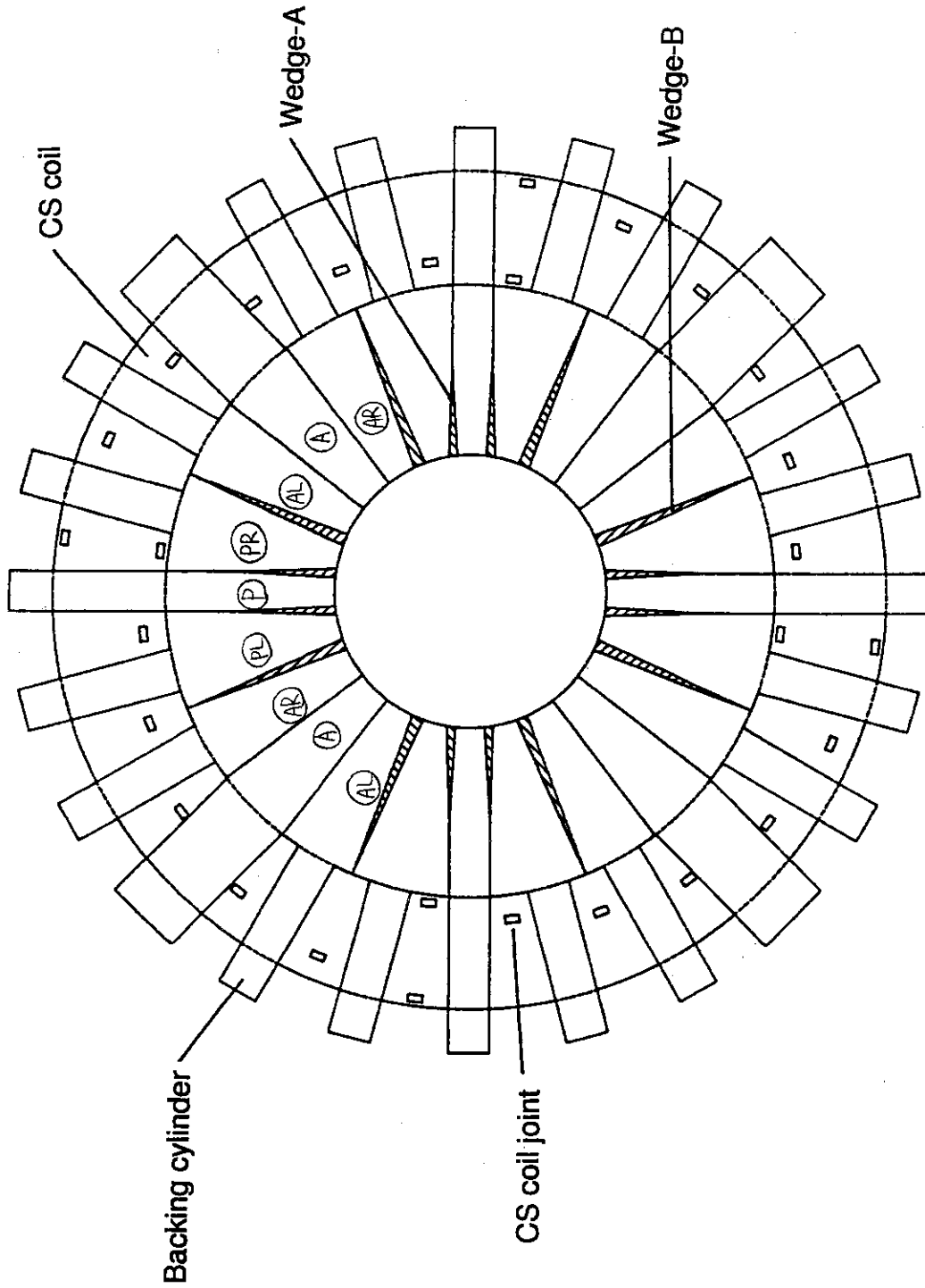

Fig. 3.3.8 Possible BC segmentation

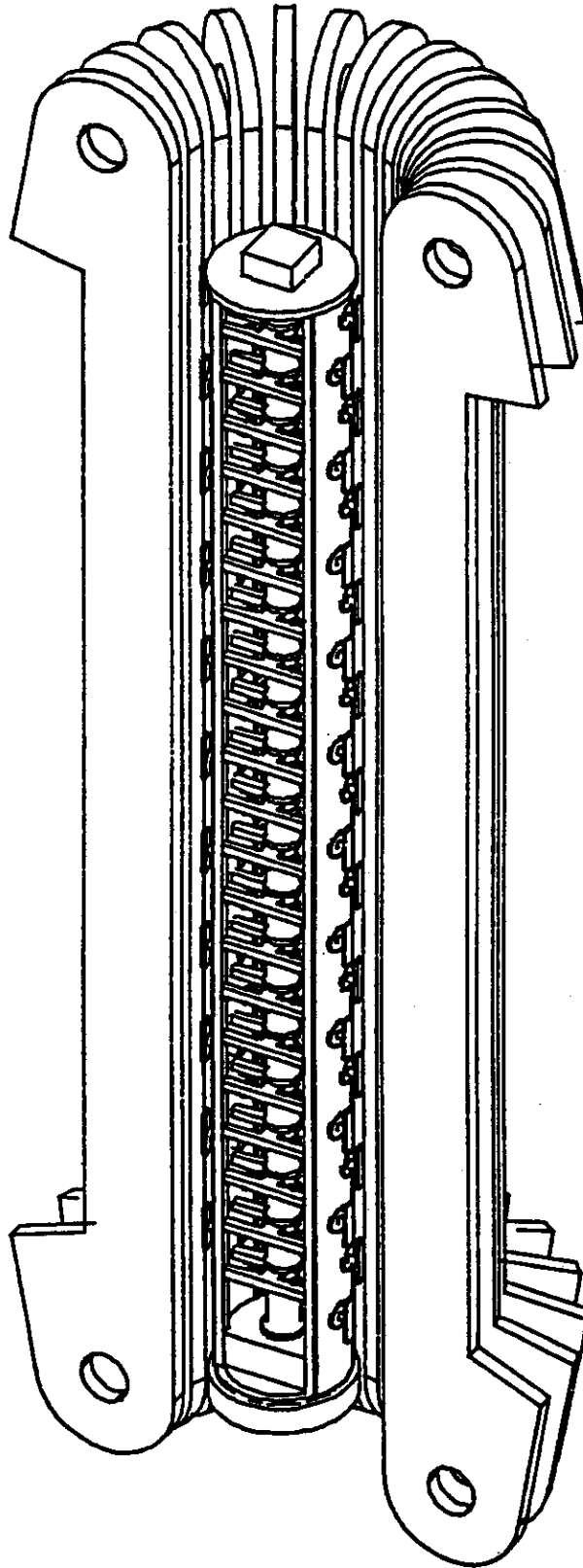

Fig. 3.3.9(a) Wedge installation system for BC assembly

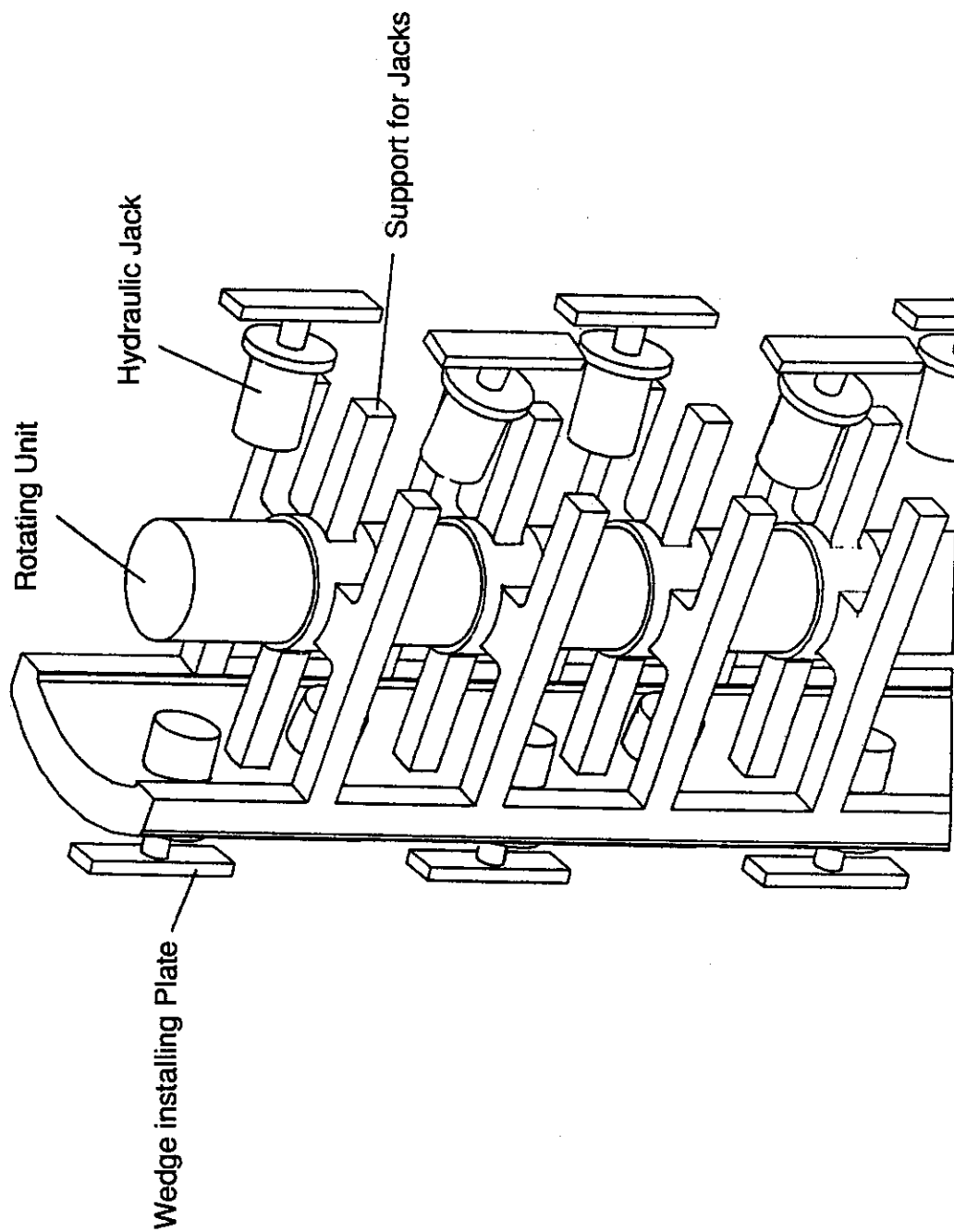

Fig. 3.3.9(b) Details of wedge installation system

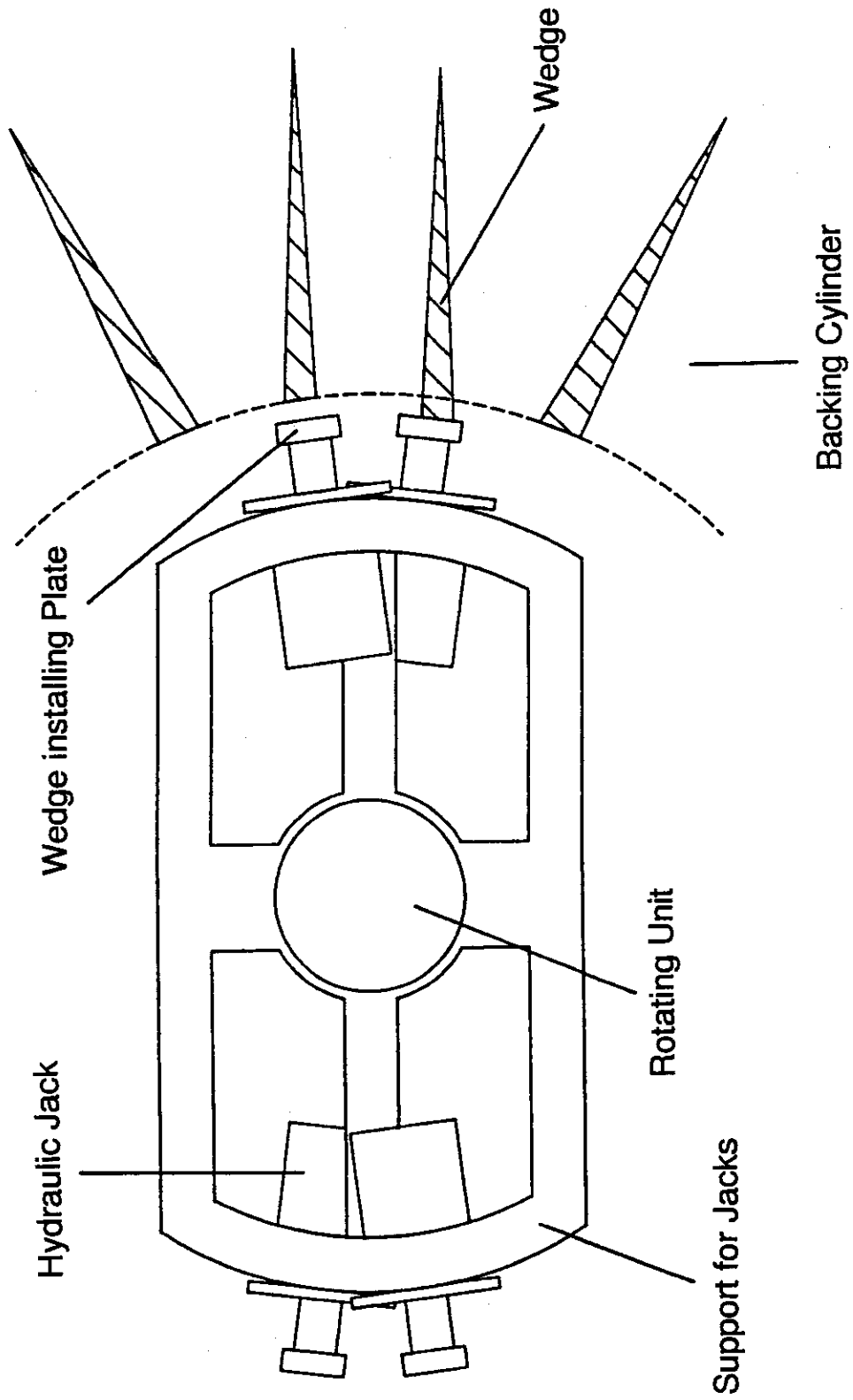

Fig. 3.3.9(c) Cross-section view of wedge installation system

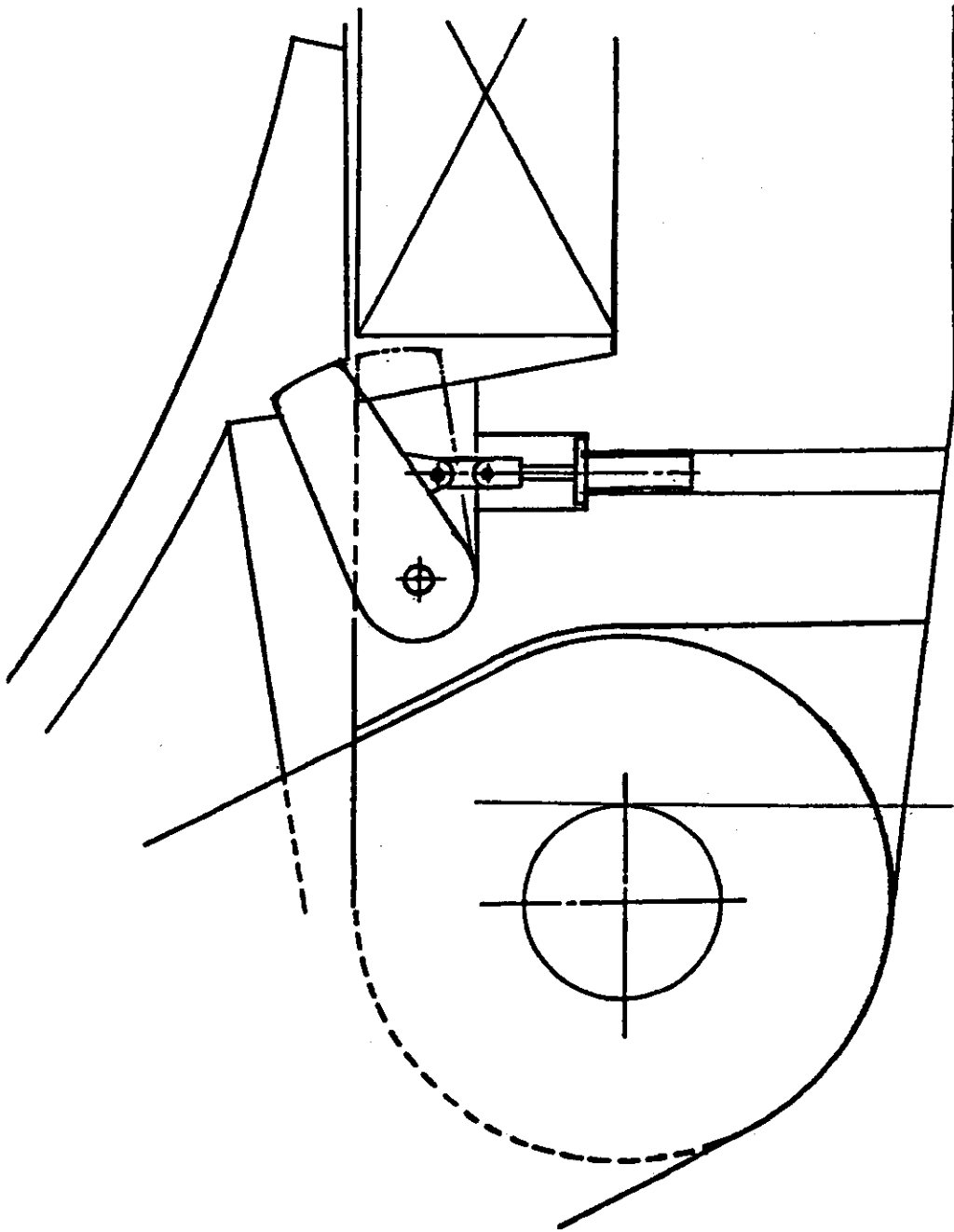

Fig. 3. 3. 10(a) Adjustment system of lower link

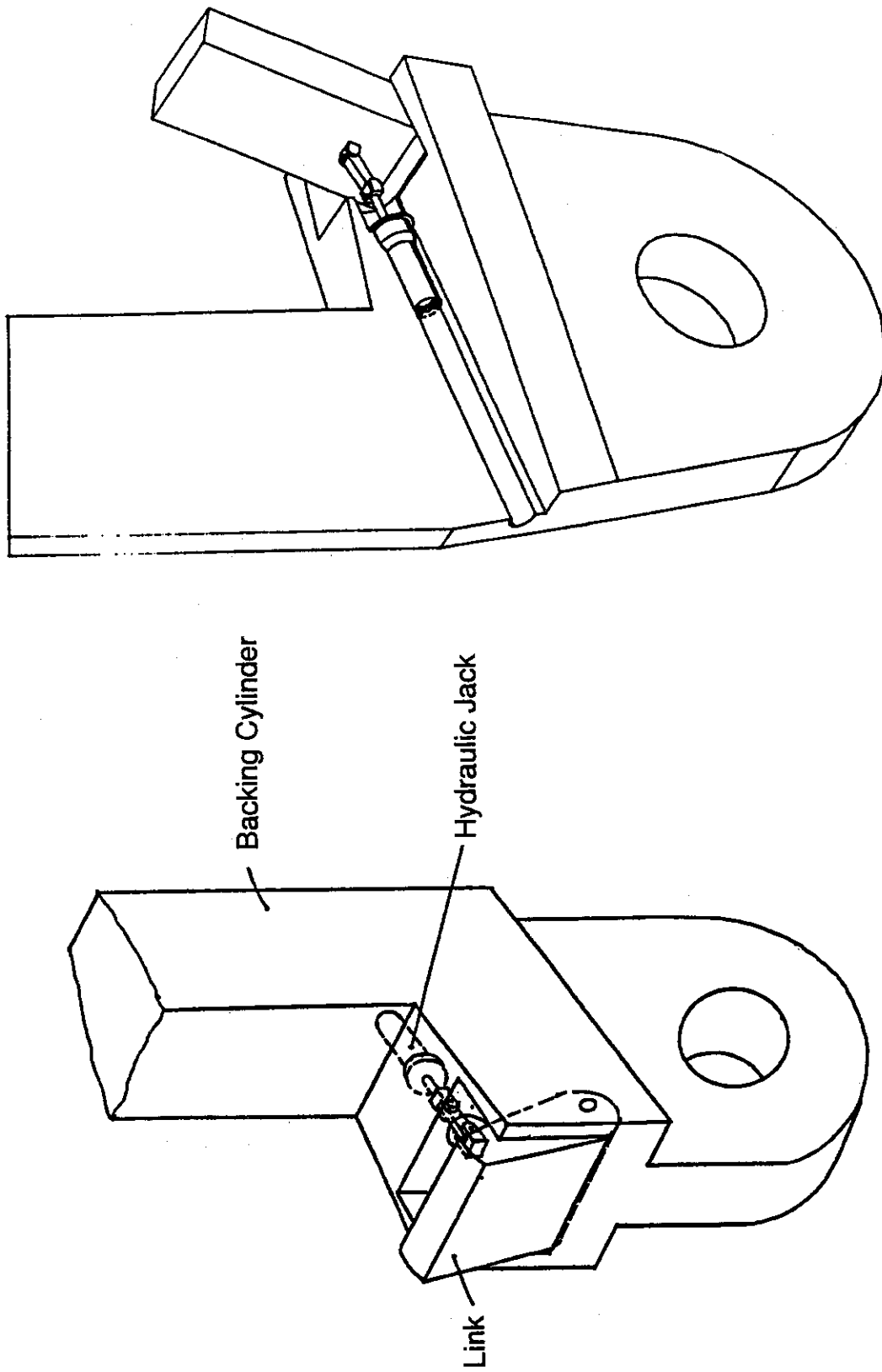

Fig. 3.3.10(b) Adjustment system of lower link

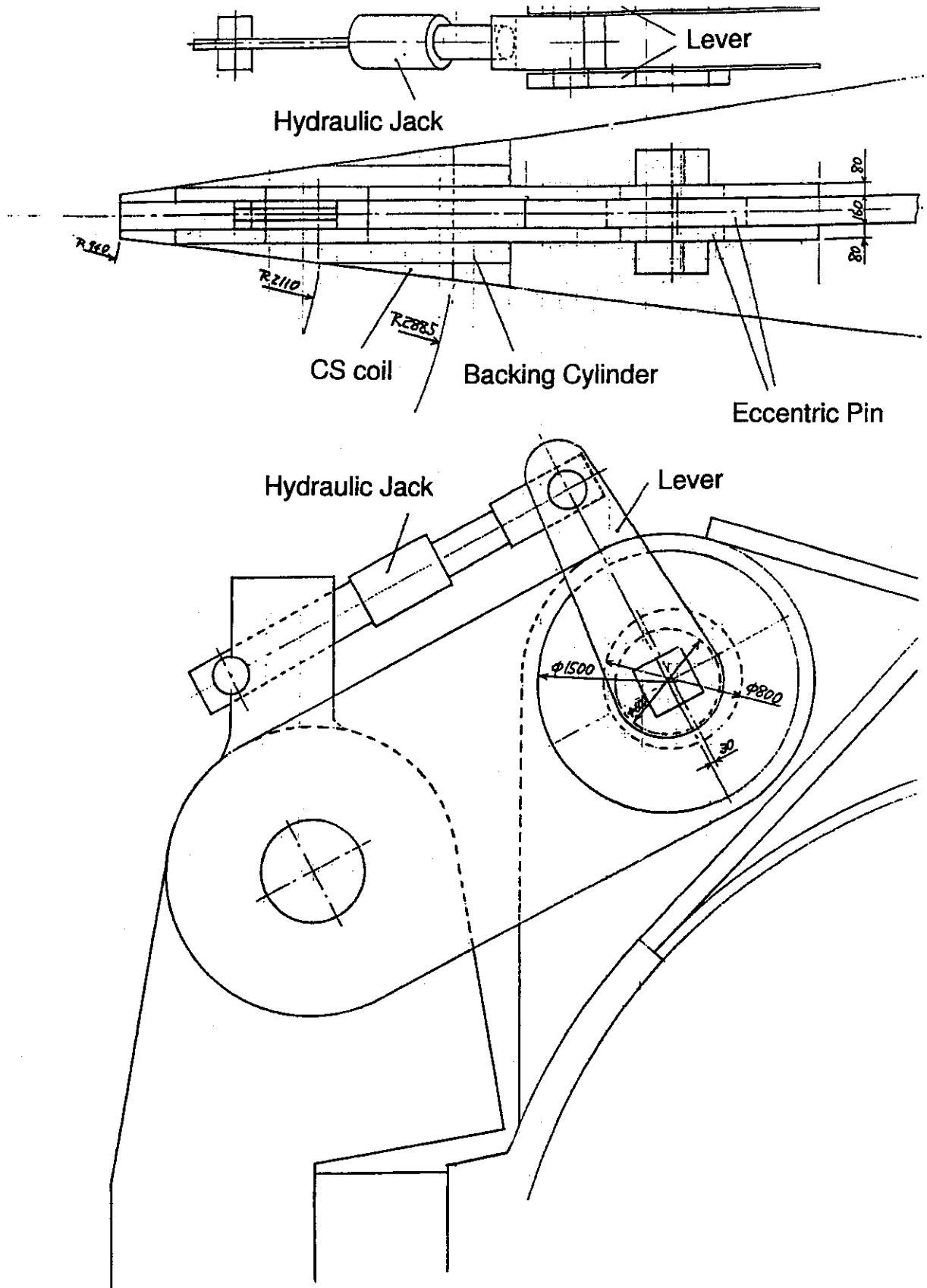

Fig. 3.3.11(a) Adjustment/fixing system of upper link

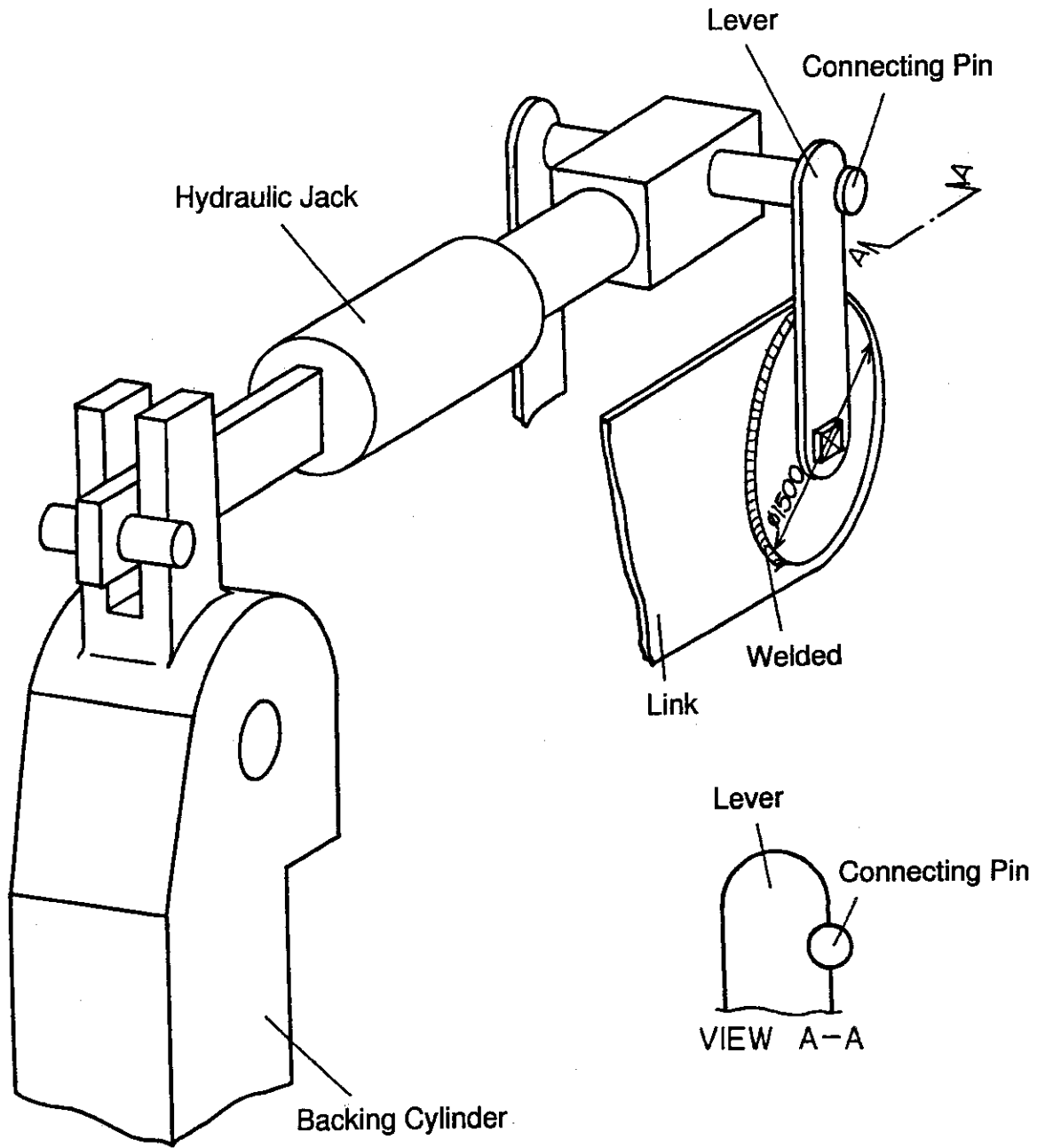

Fig. 3.3.11(b) Adjustment/fixing system of upper link

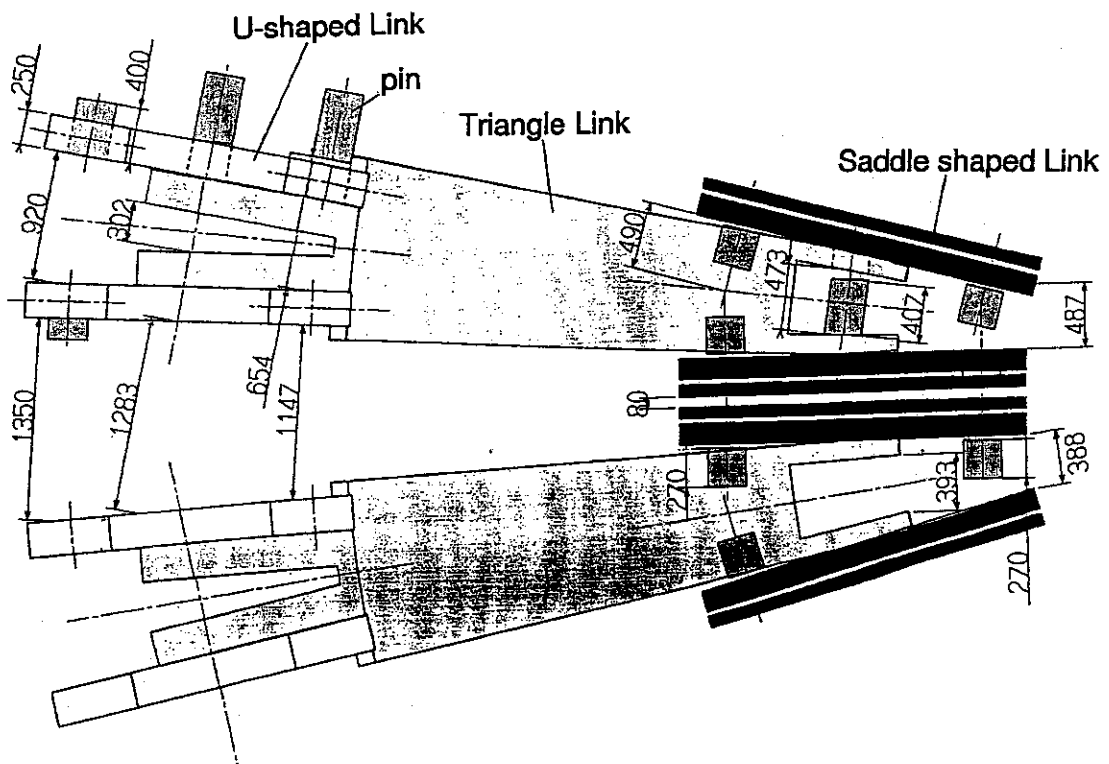
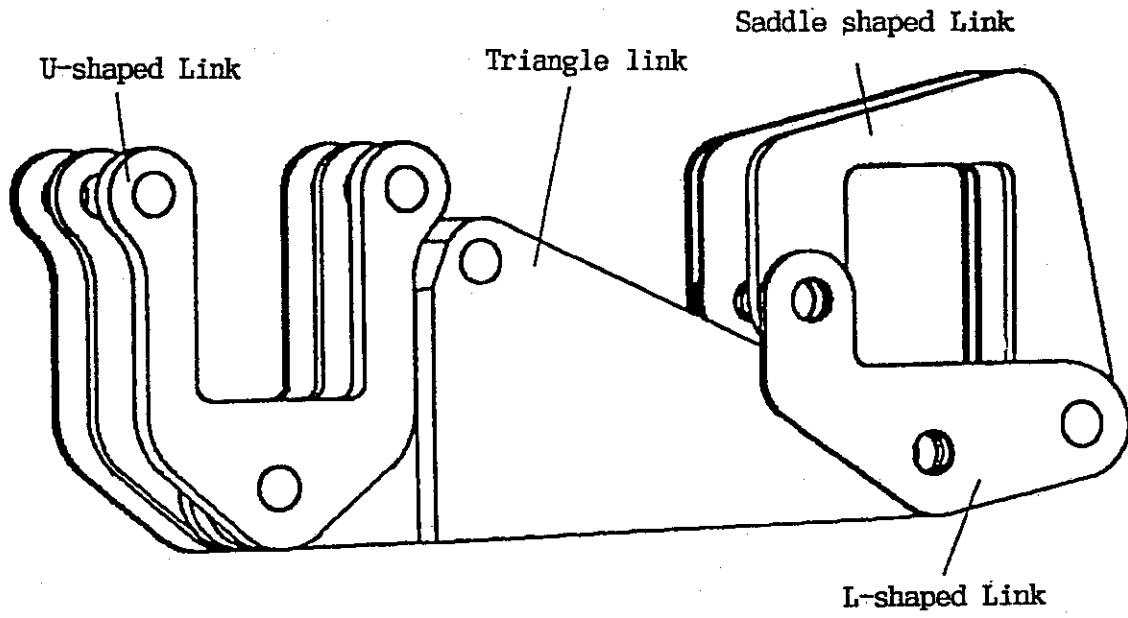
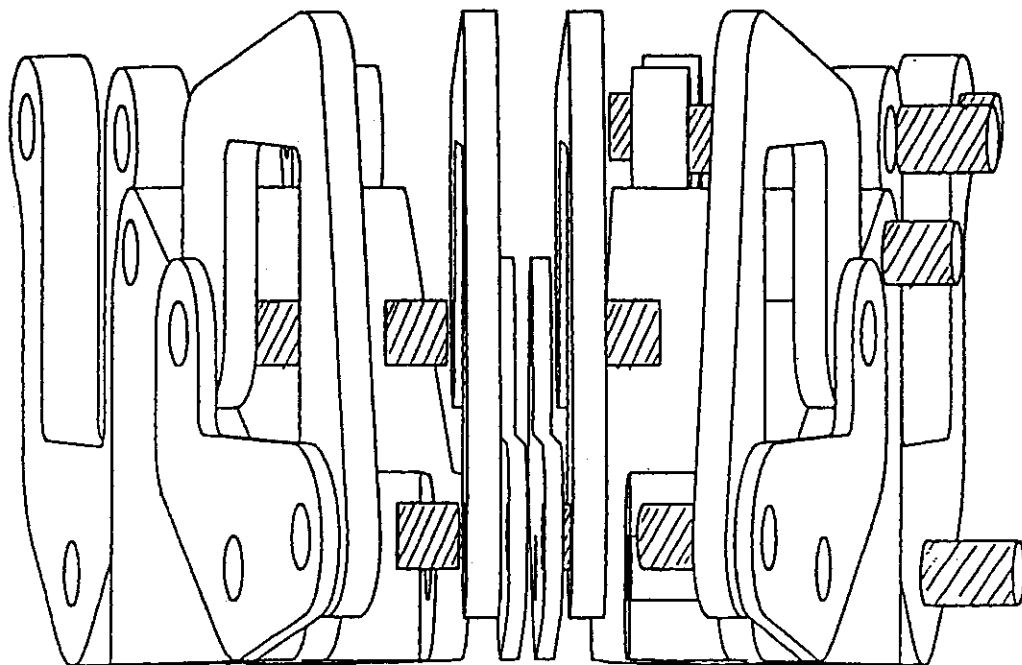
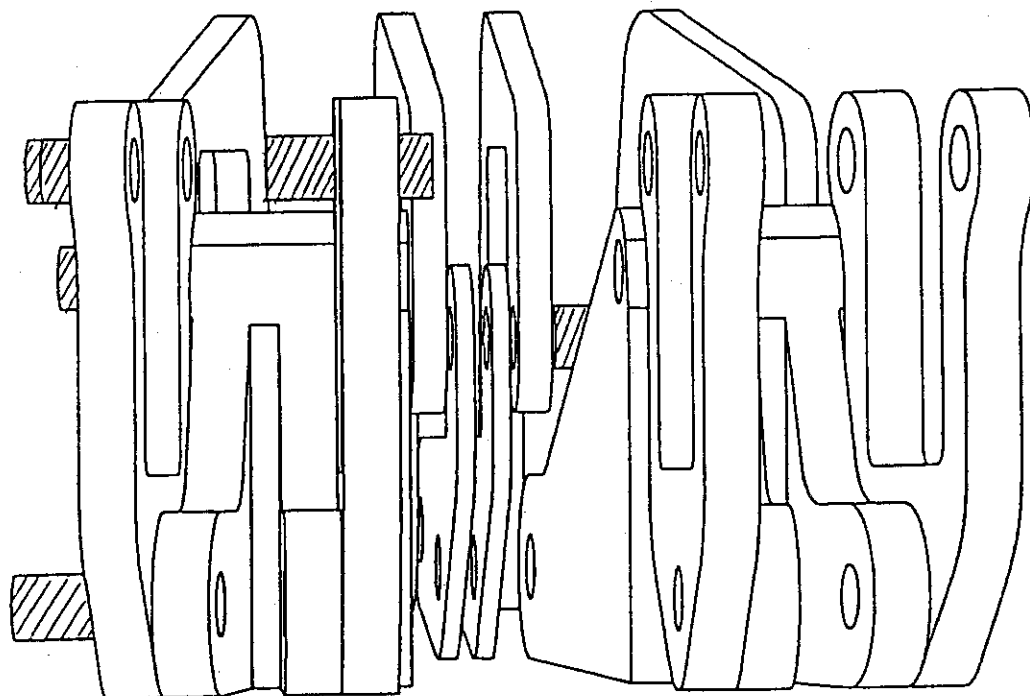

Fig. 3.3.12 Space for disassembling of link system



(A) Front view



(B) Back view

Fig. 3.3.13 Overall view of links and pins

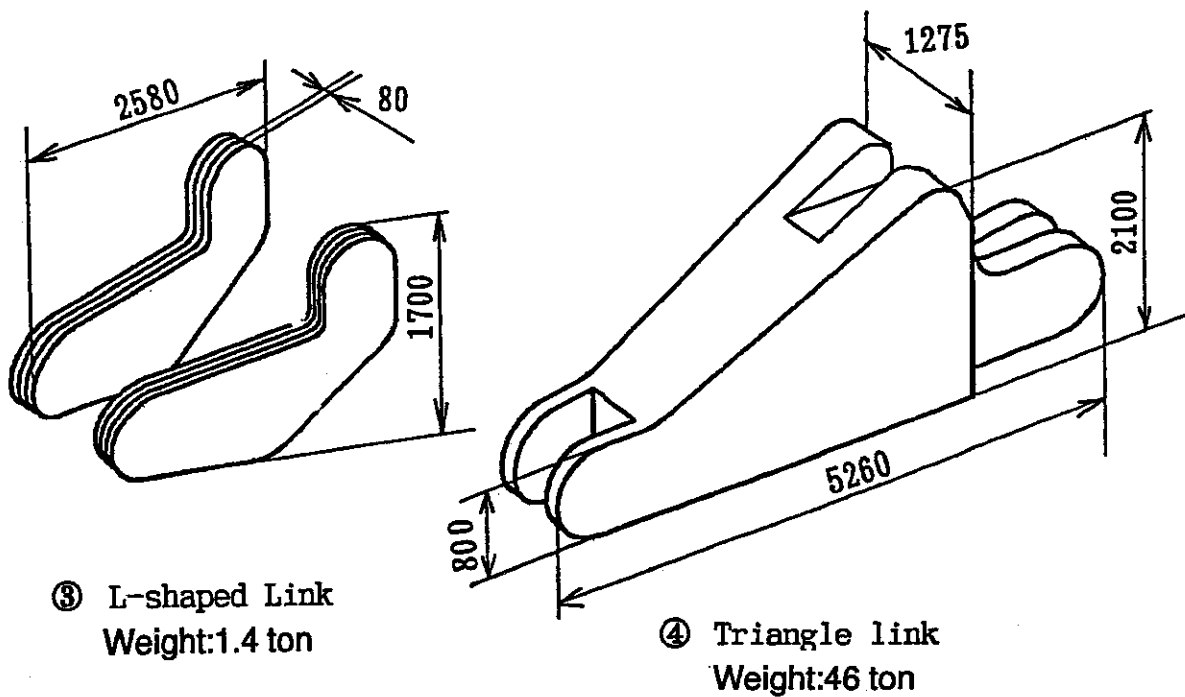
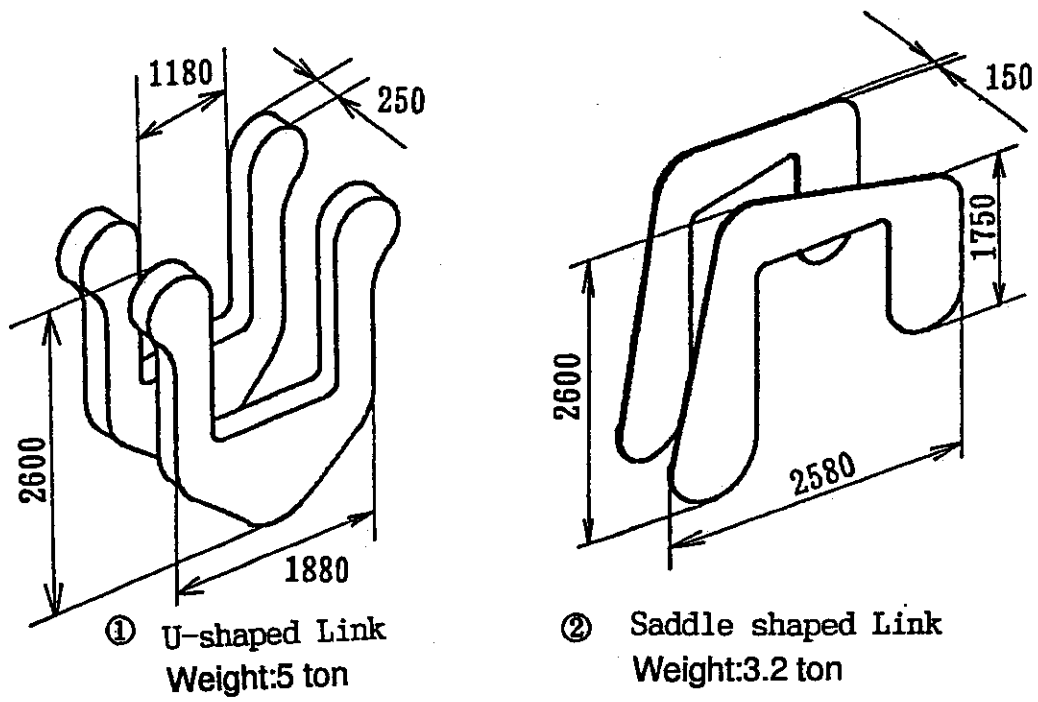

Fig. 3.3.14 Parts of link

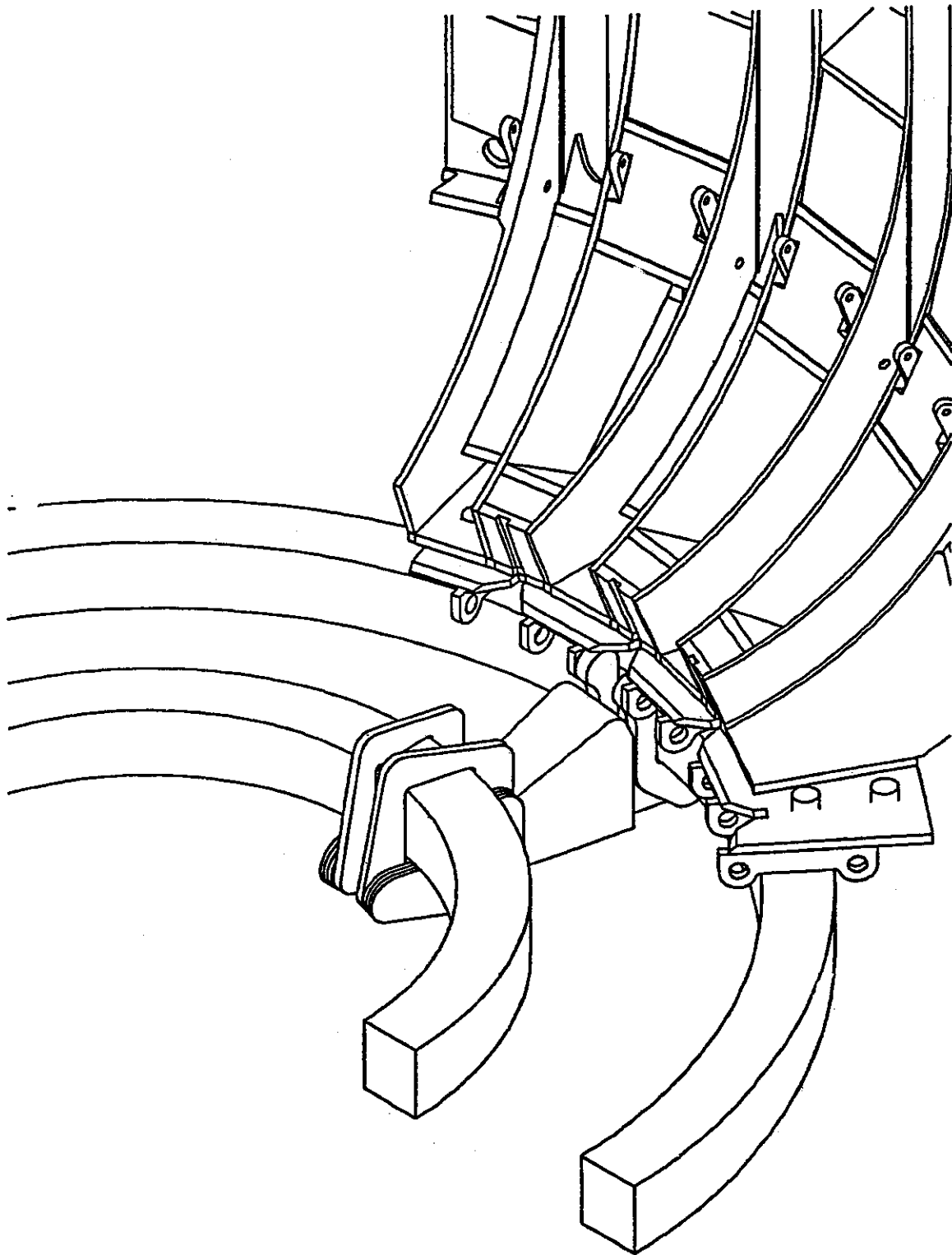

Fig. 3.3.15 Birds view of link system

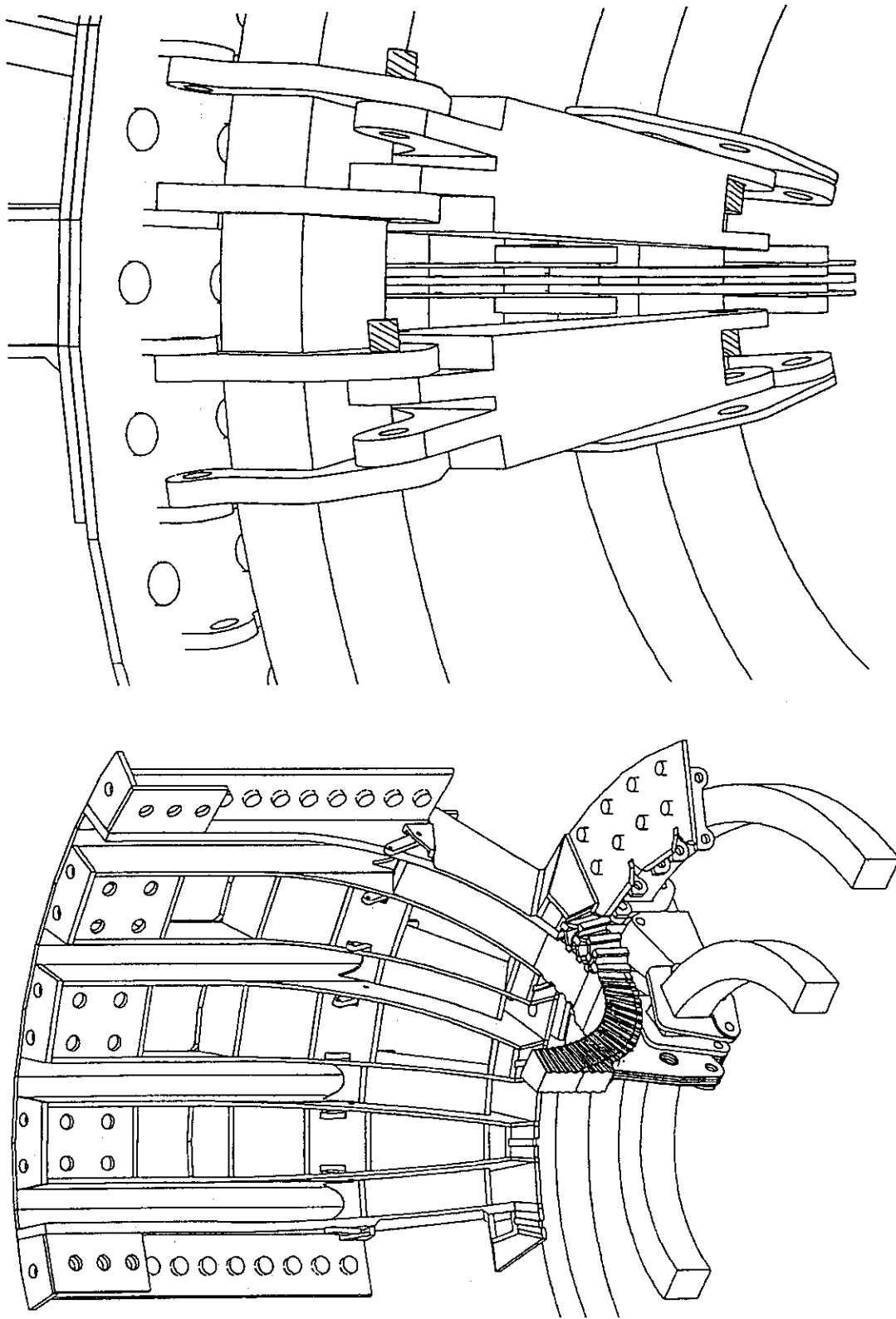

Fig. 3.3.16(a) Removal of triangle link

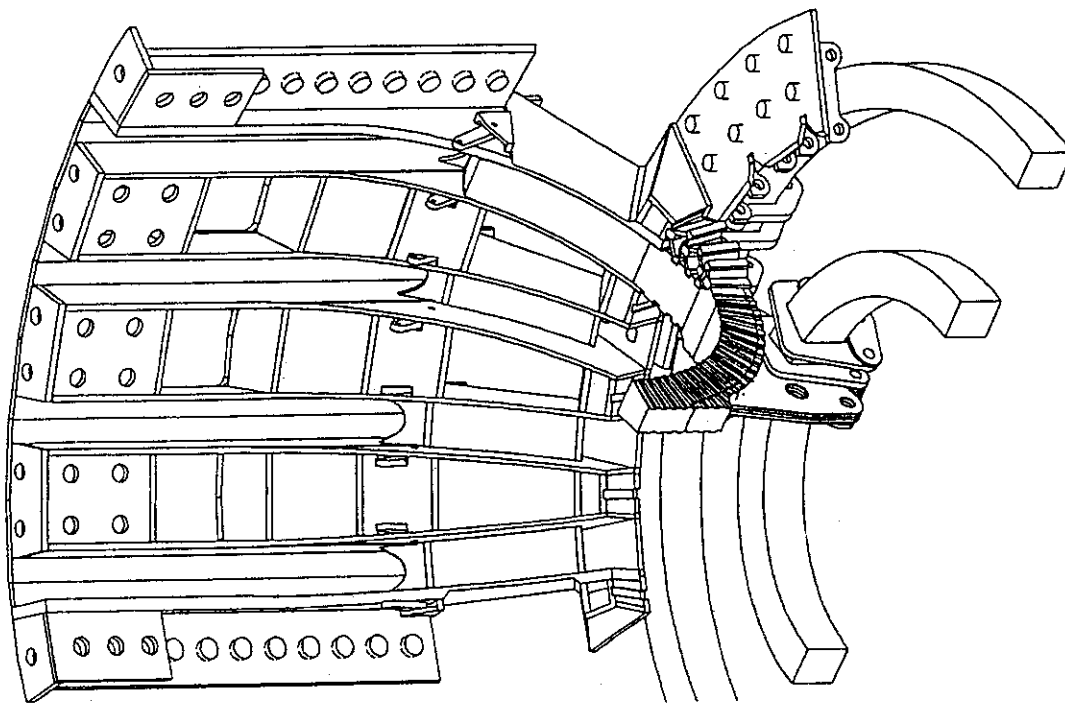
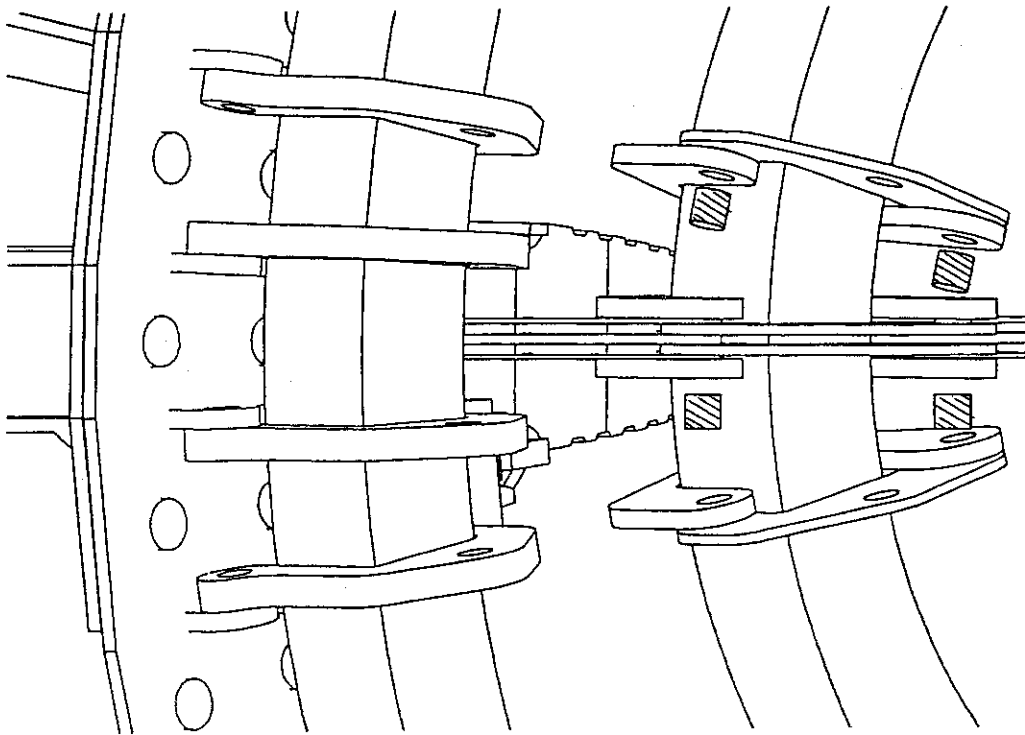

Fig. 3.3.16(b) Removal of L-shaped link

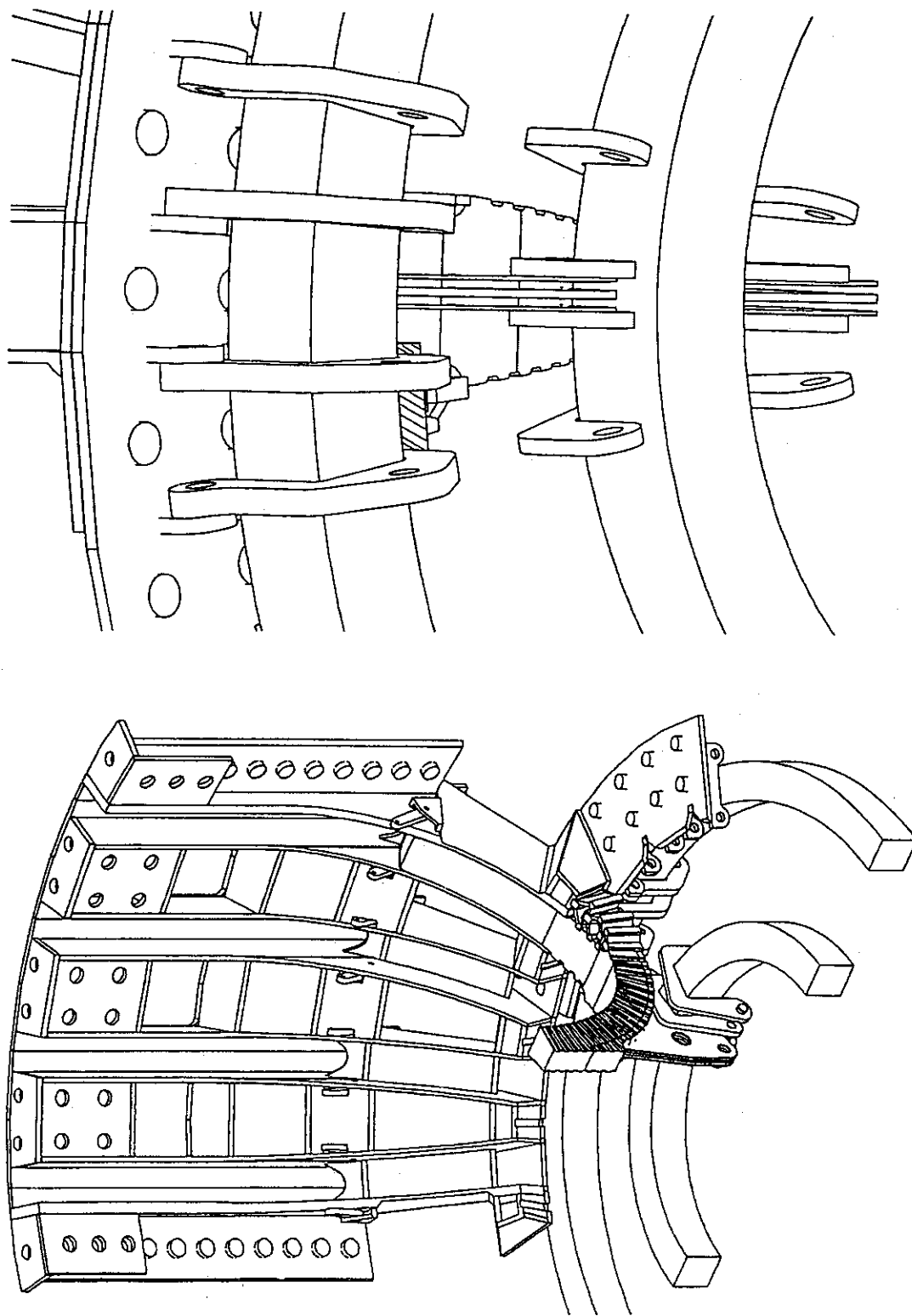

Fig. 3.3.16(c) Removal of PF-7 and saddle shaped link

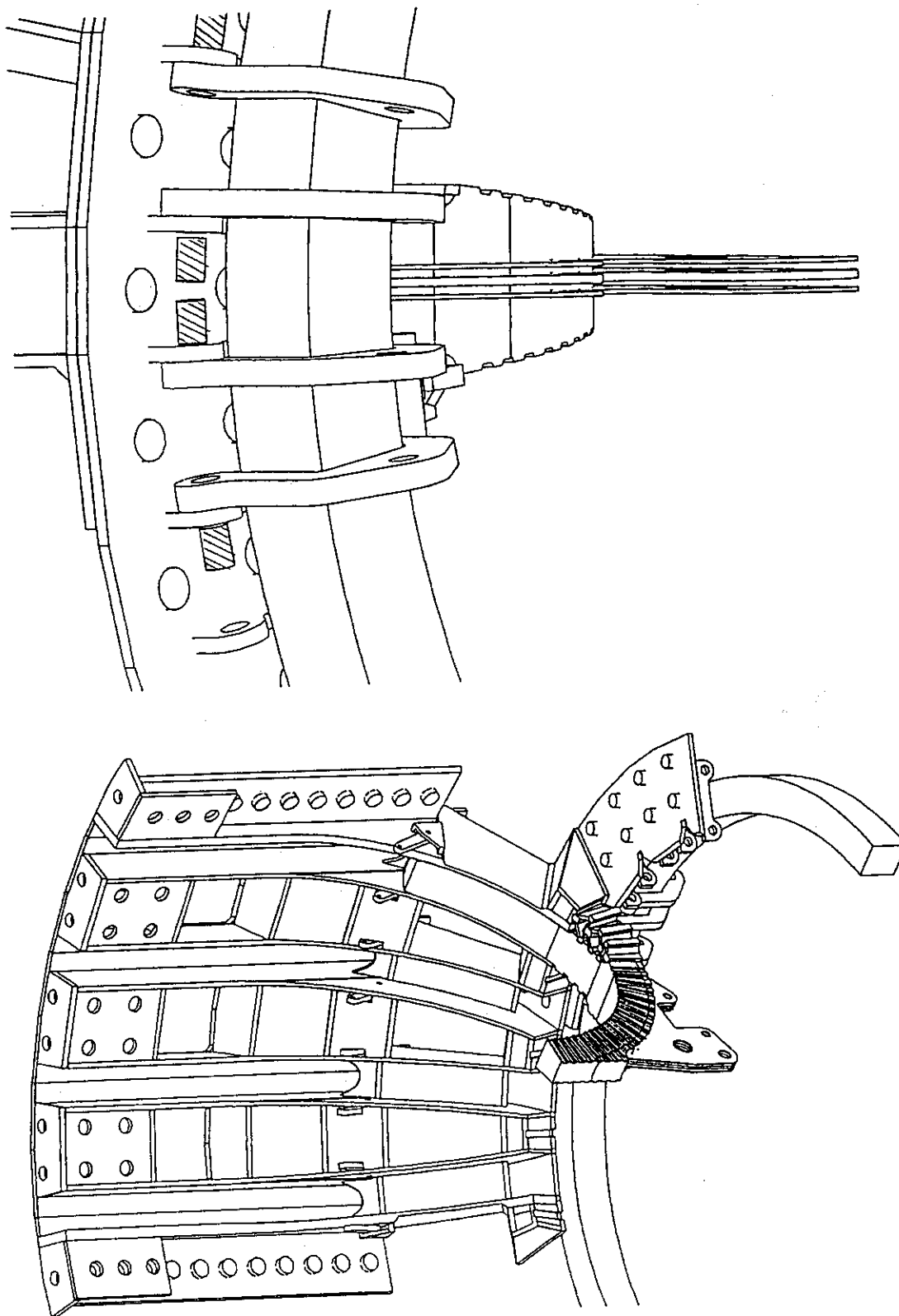

Fig. 3. 3. 16(d) Removal of U-shaped link

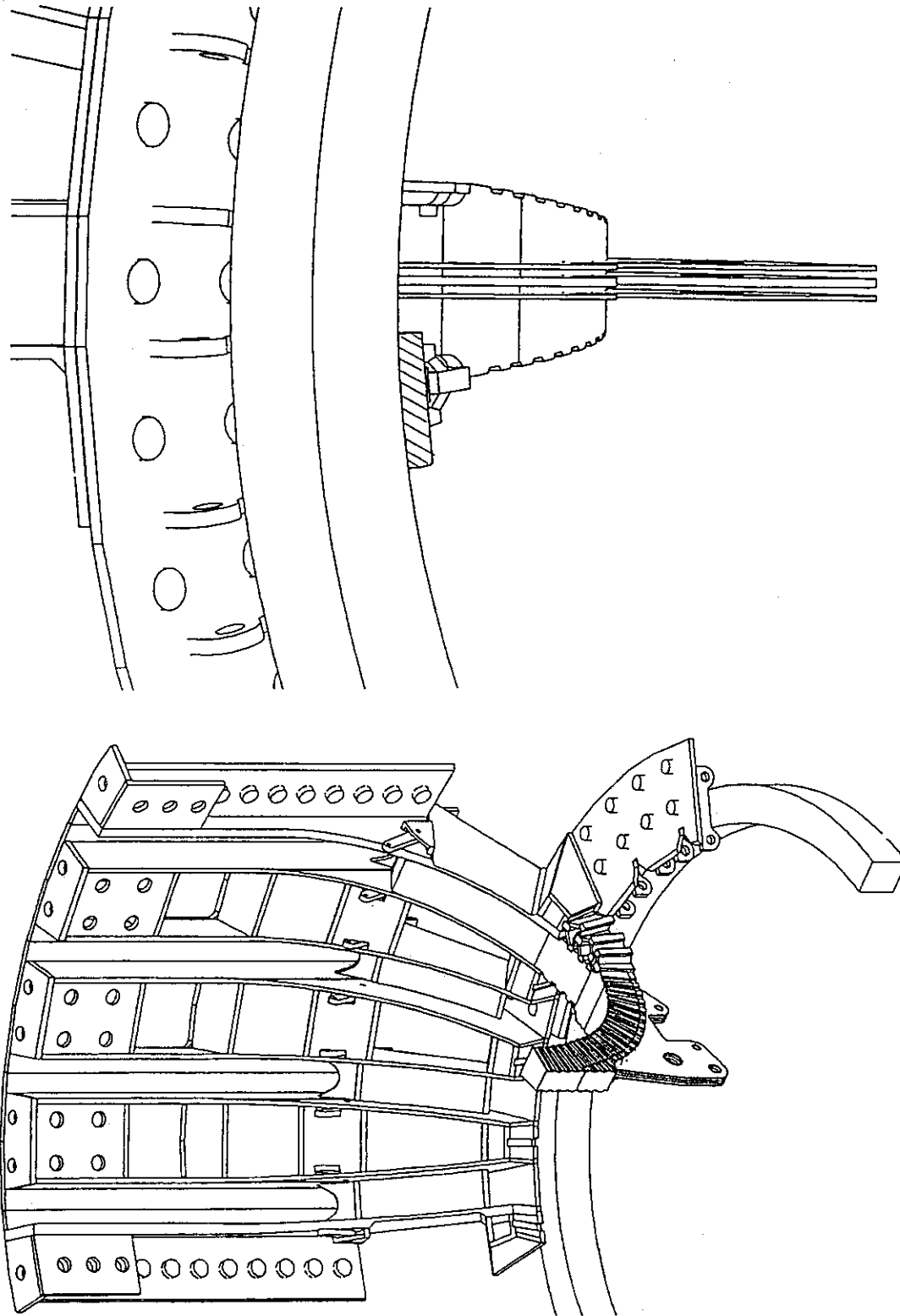

Fig. 3.3.16(e) Removal of PF-6

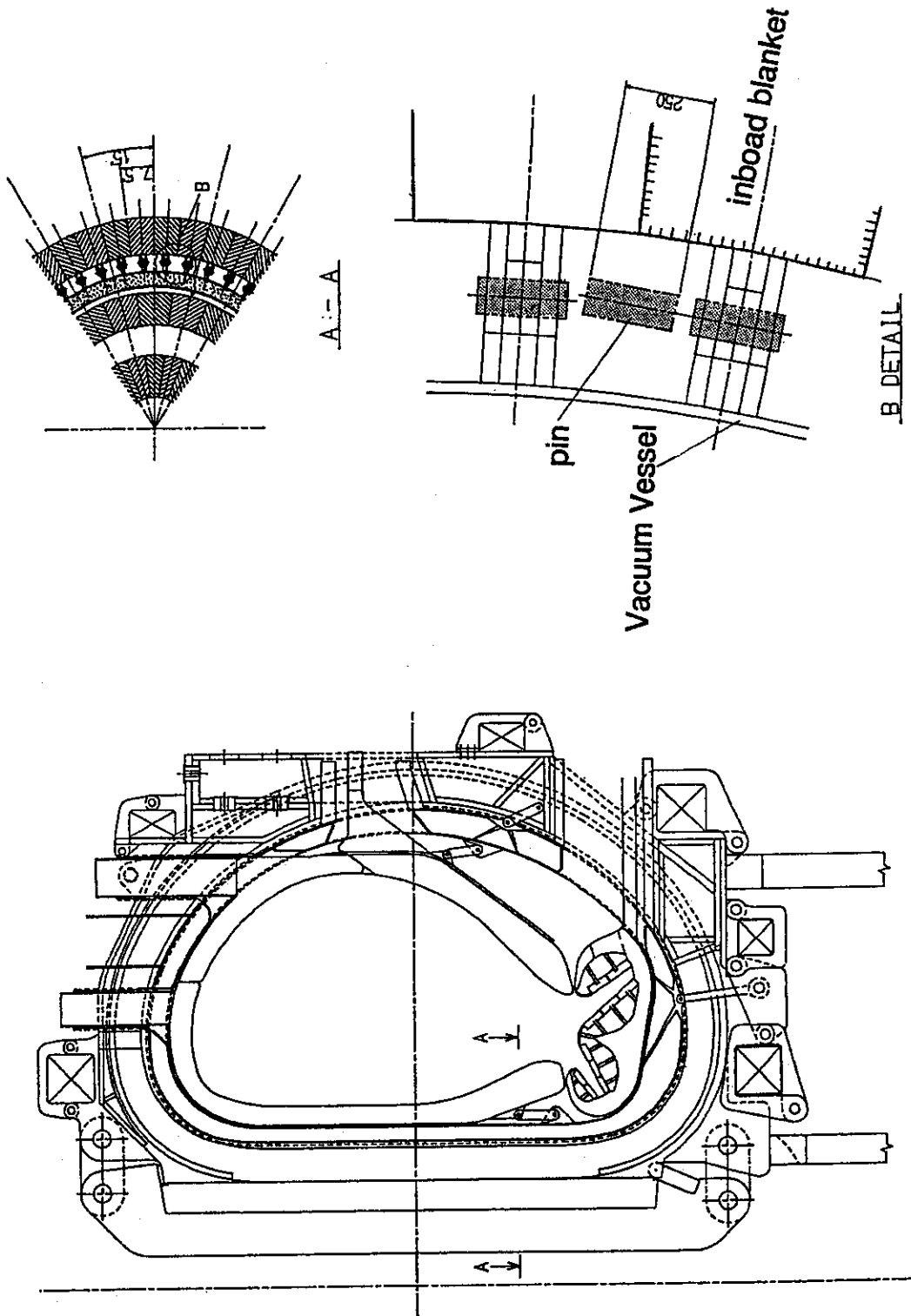

Fig. 3.4.1 Pin insertion for space

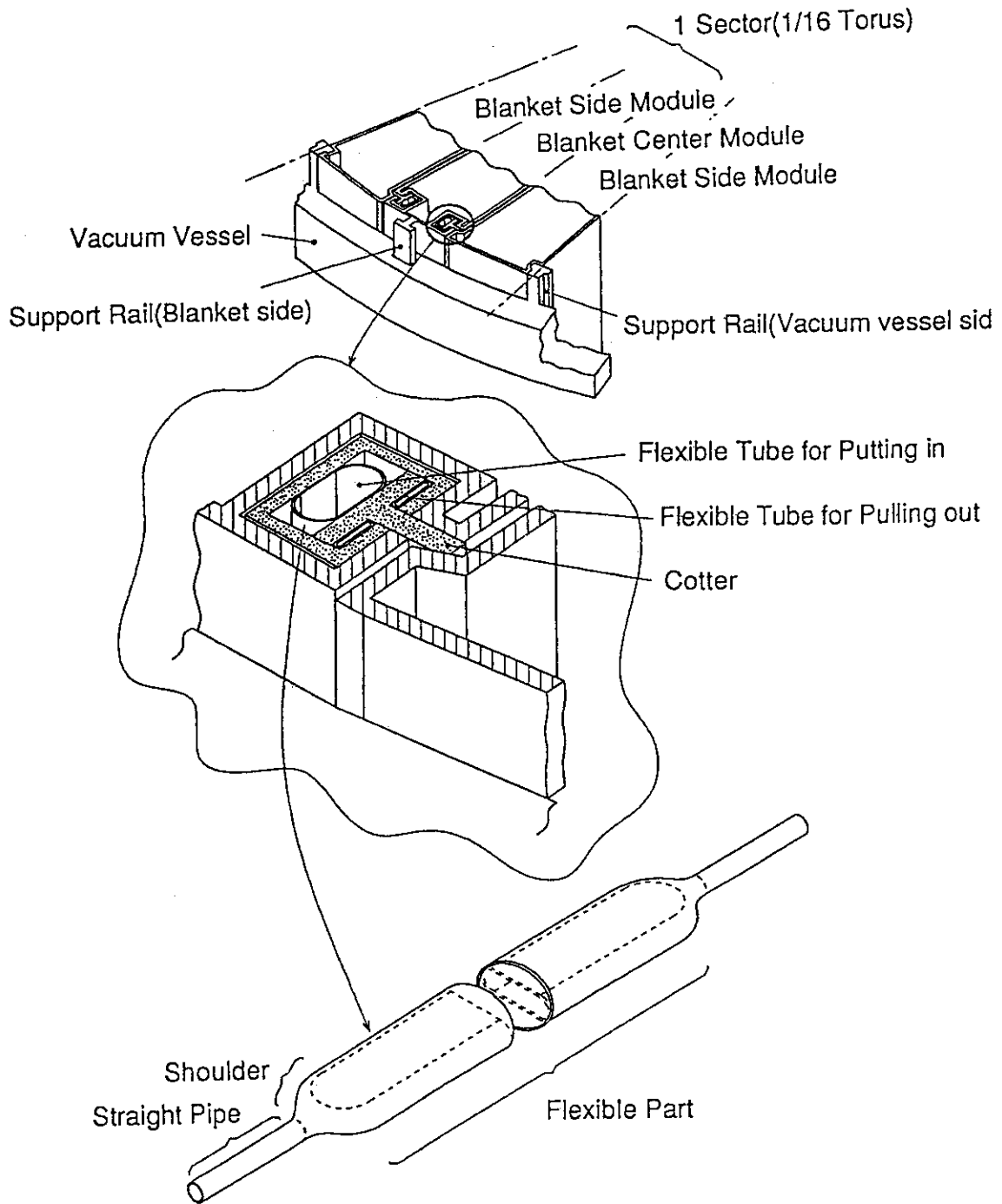

Fig. 3.4.2 Blanket support design

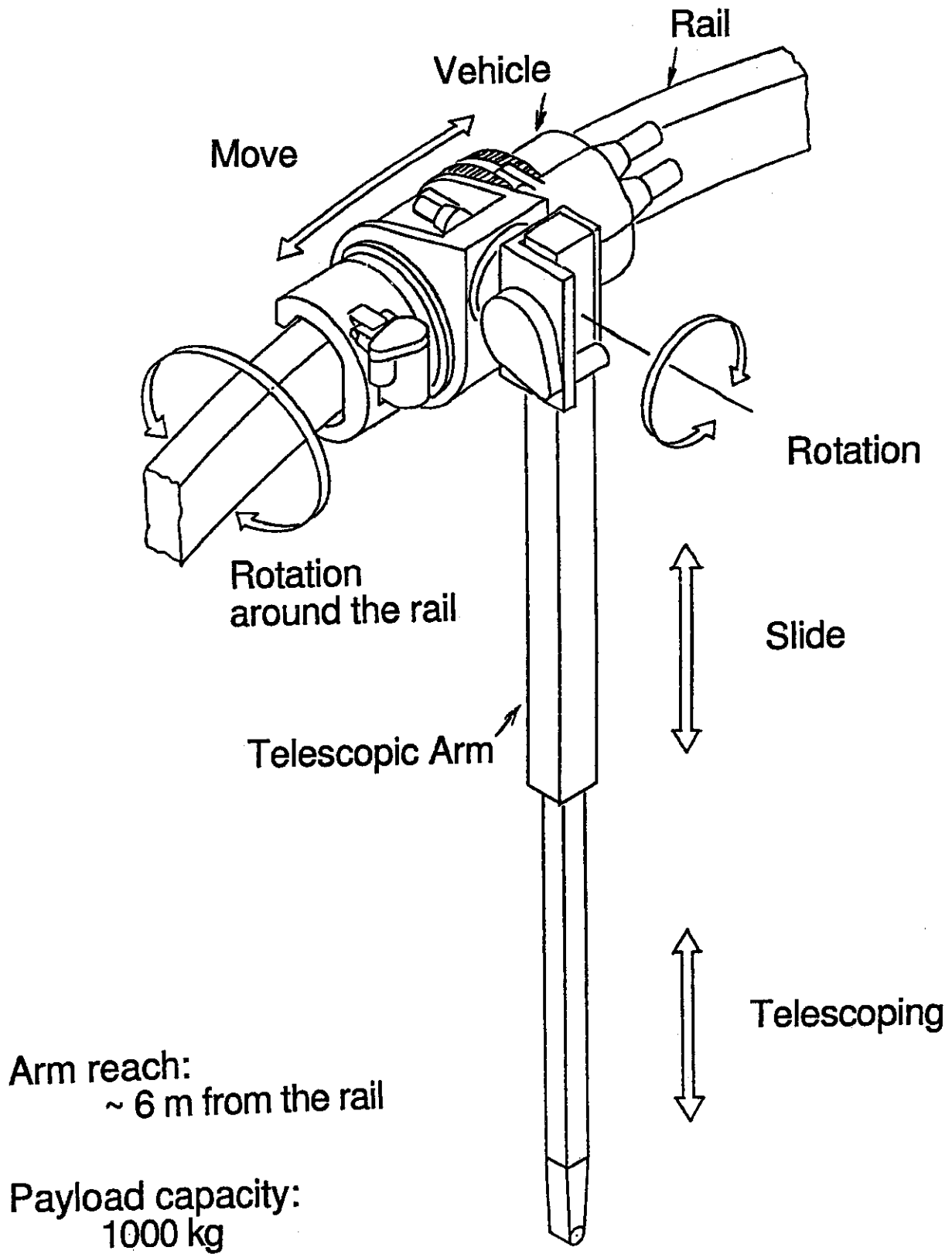

Fig. 3.4.3 Overview of the vehicle manipulator

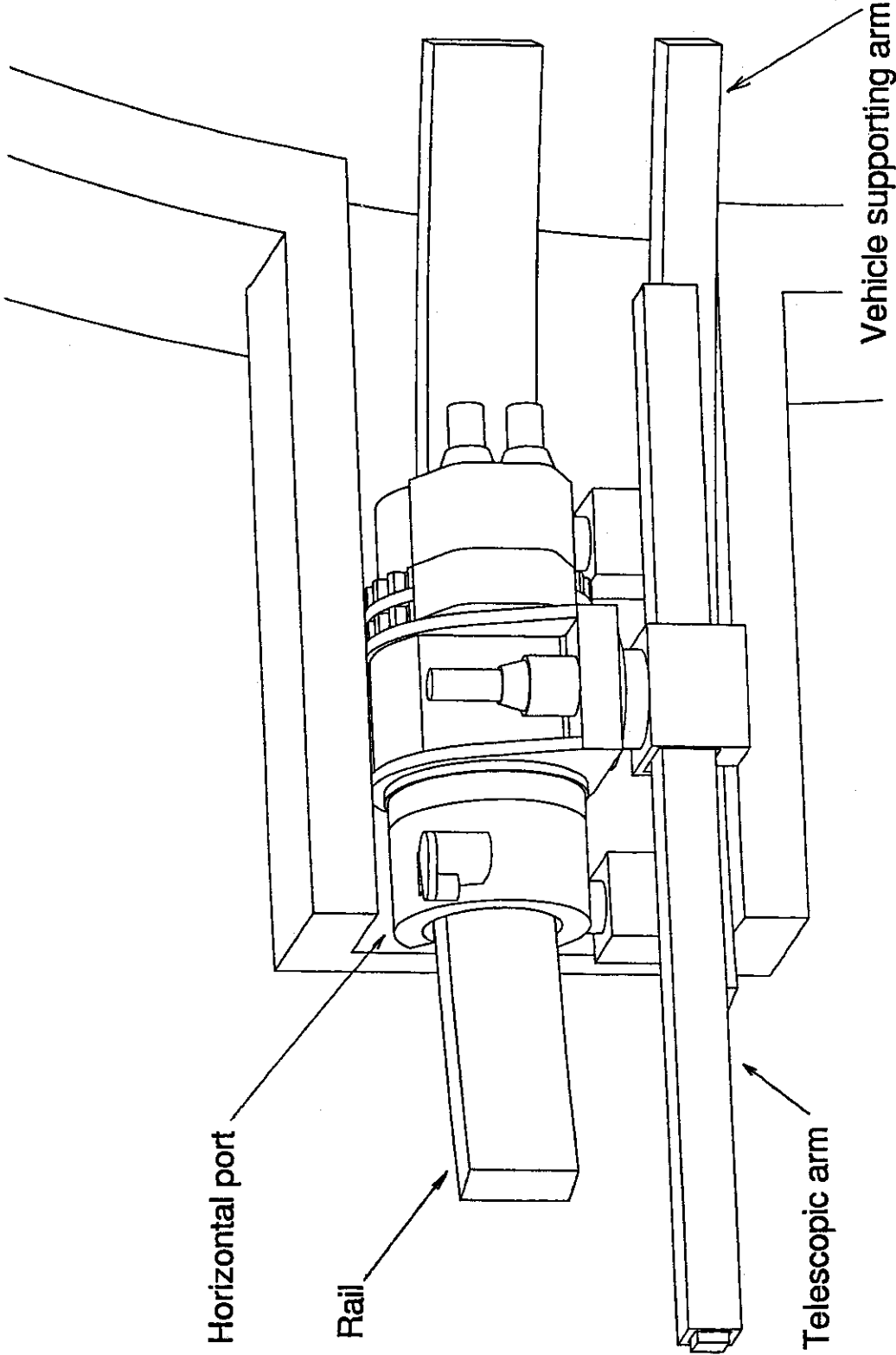

Fig. 3. 4. 4 Vehicle posture in the horizontal port

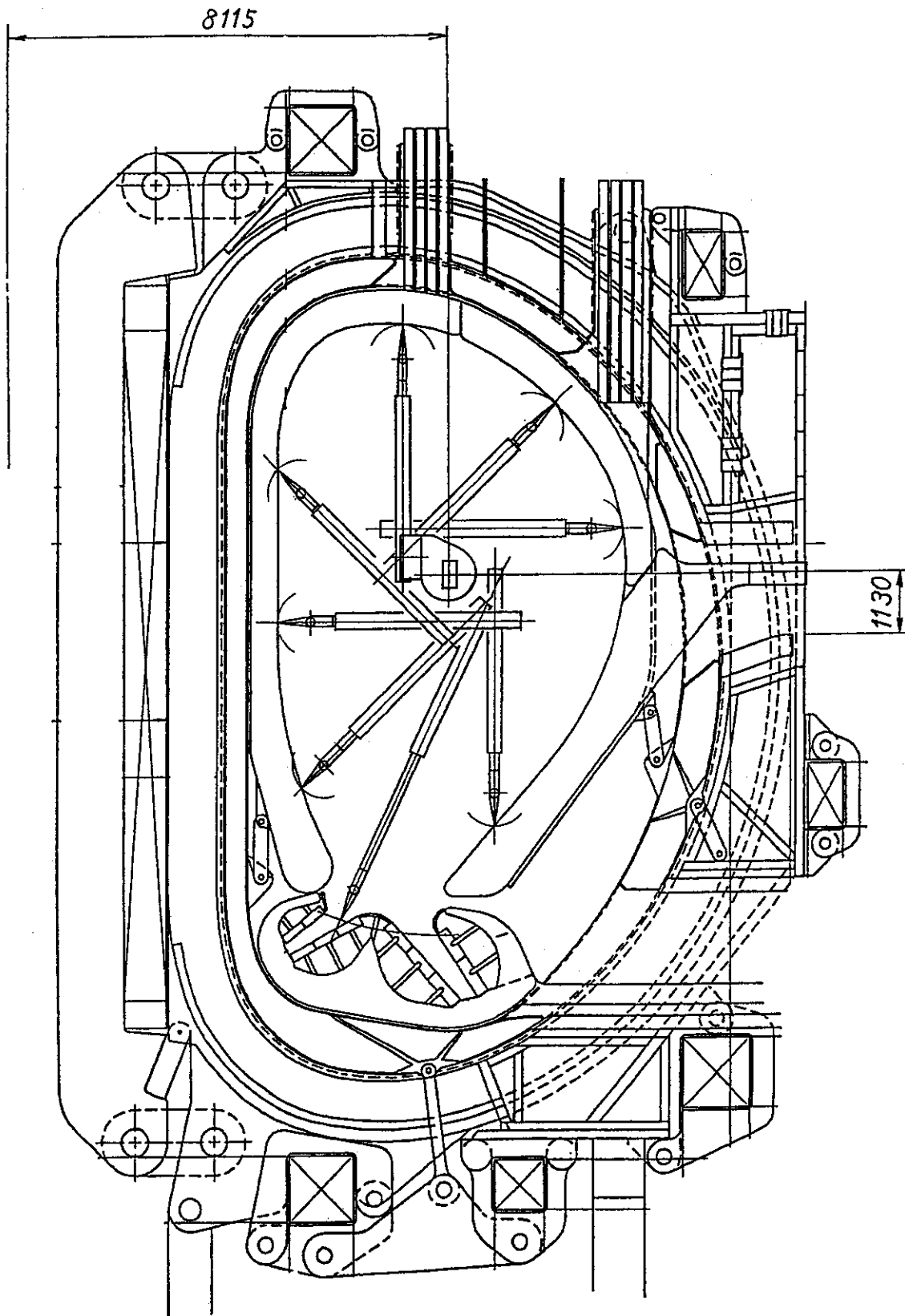

Fig. 3.4.5 Operating area of the manipulator

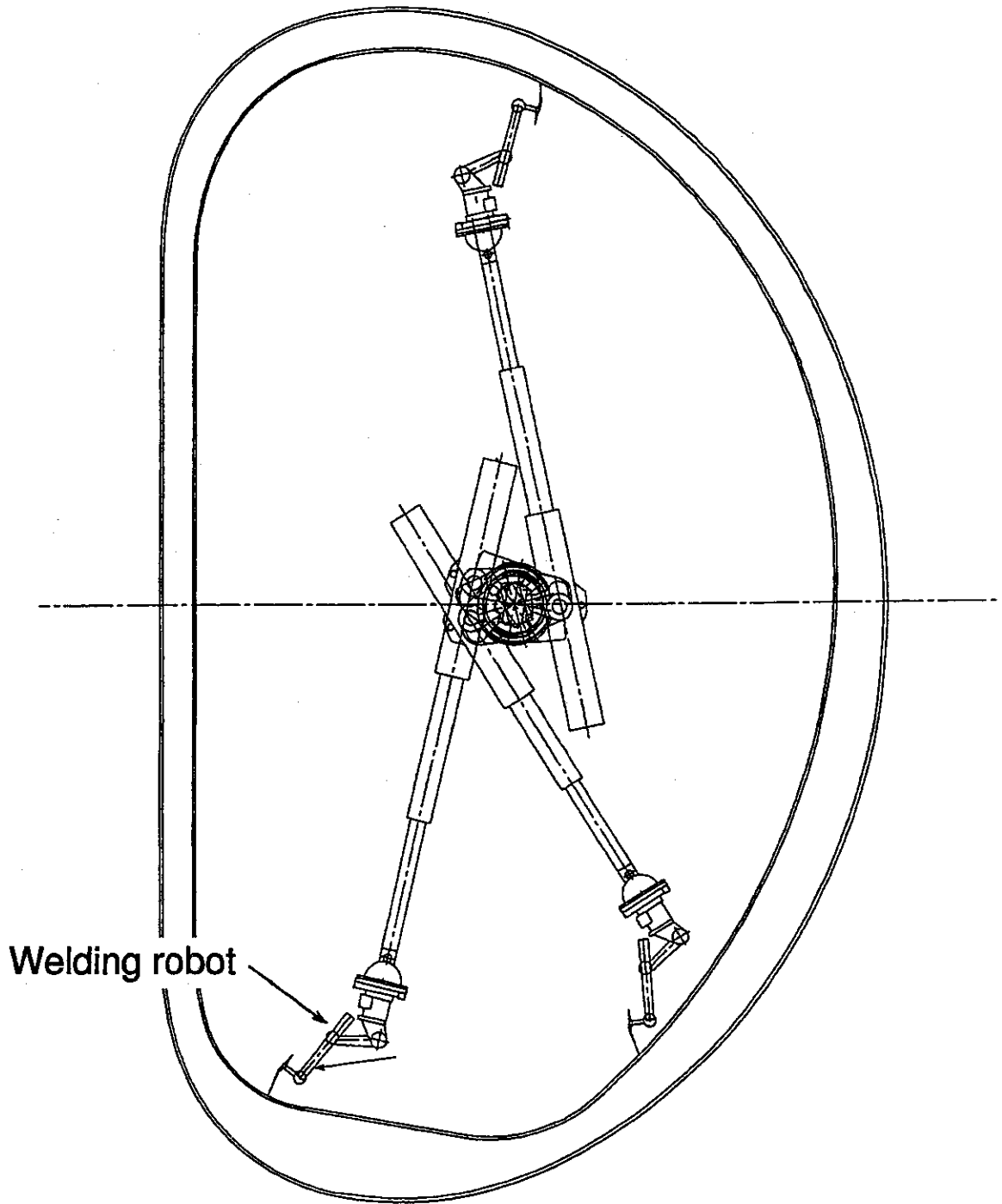

Fig. 3.4.6 Welding robot mounted on the telescopic arm

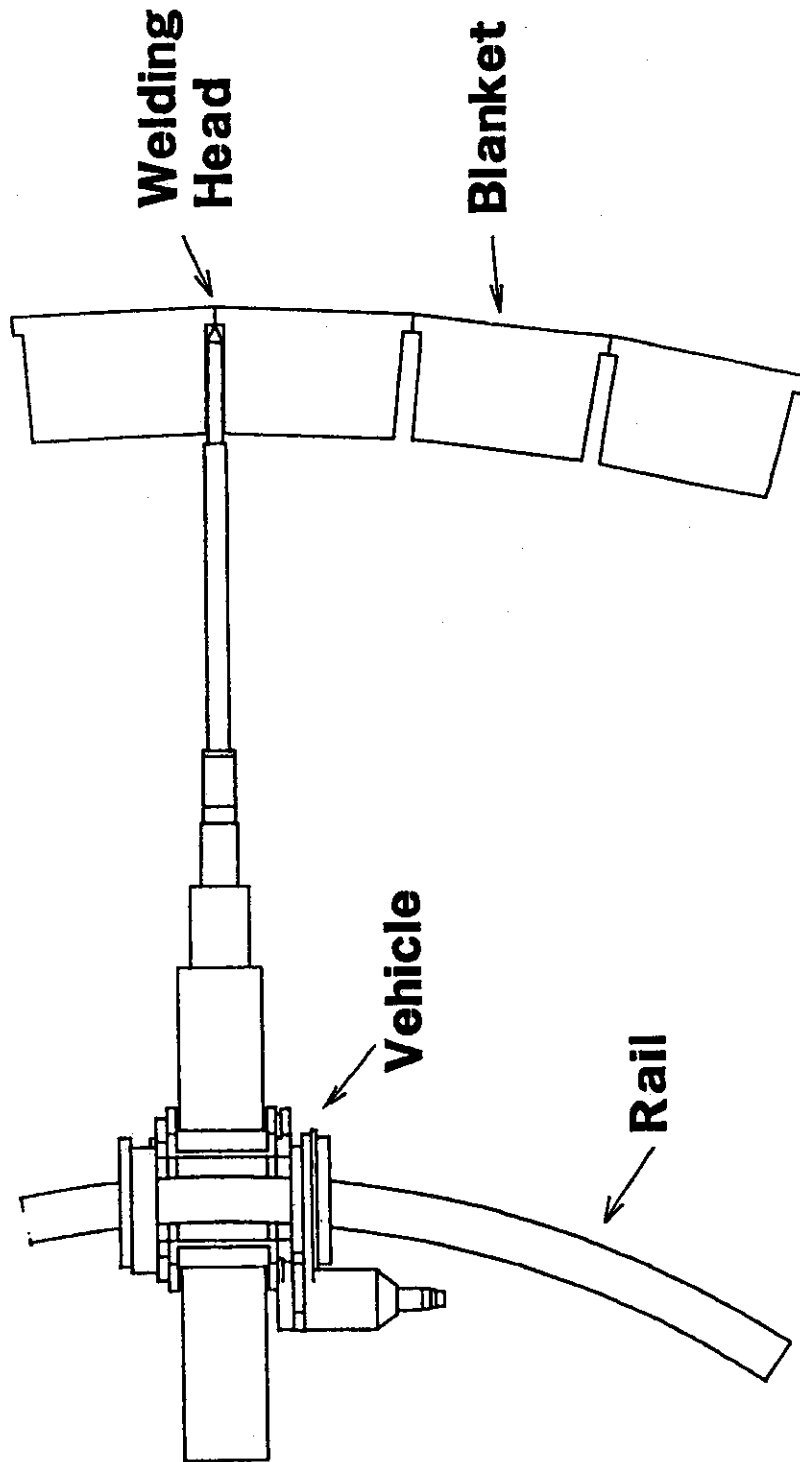

Fig. 3.4.7 Welding of the blanket's back plate

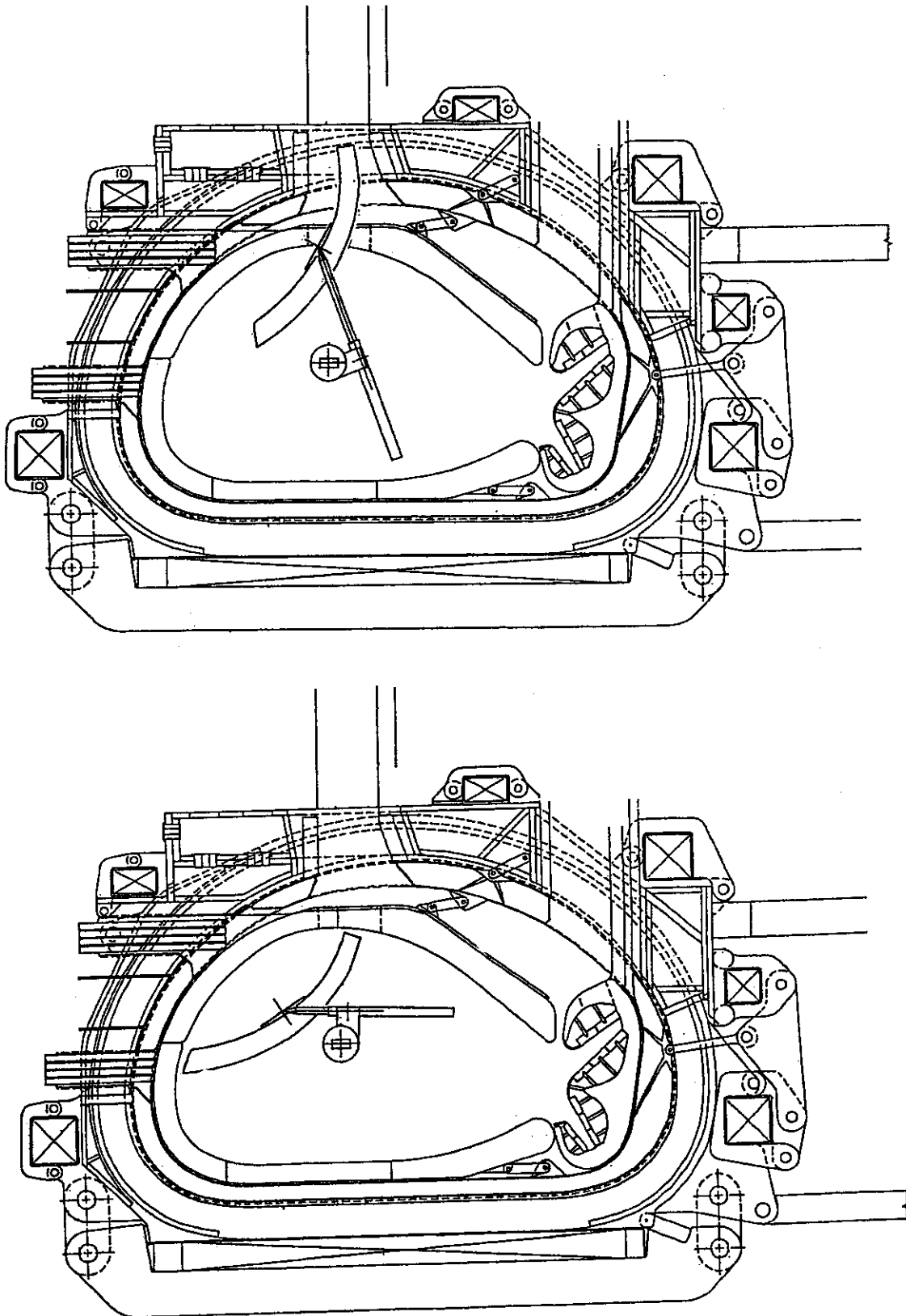

Fig. 3.4.8 Procedure of small canister handling

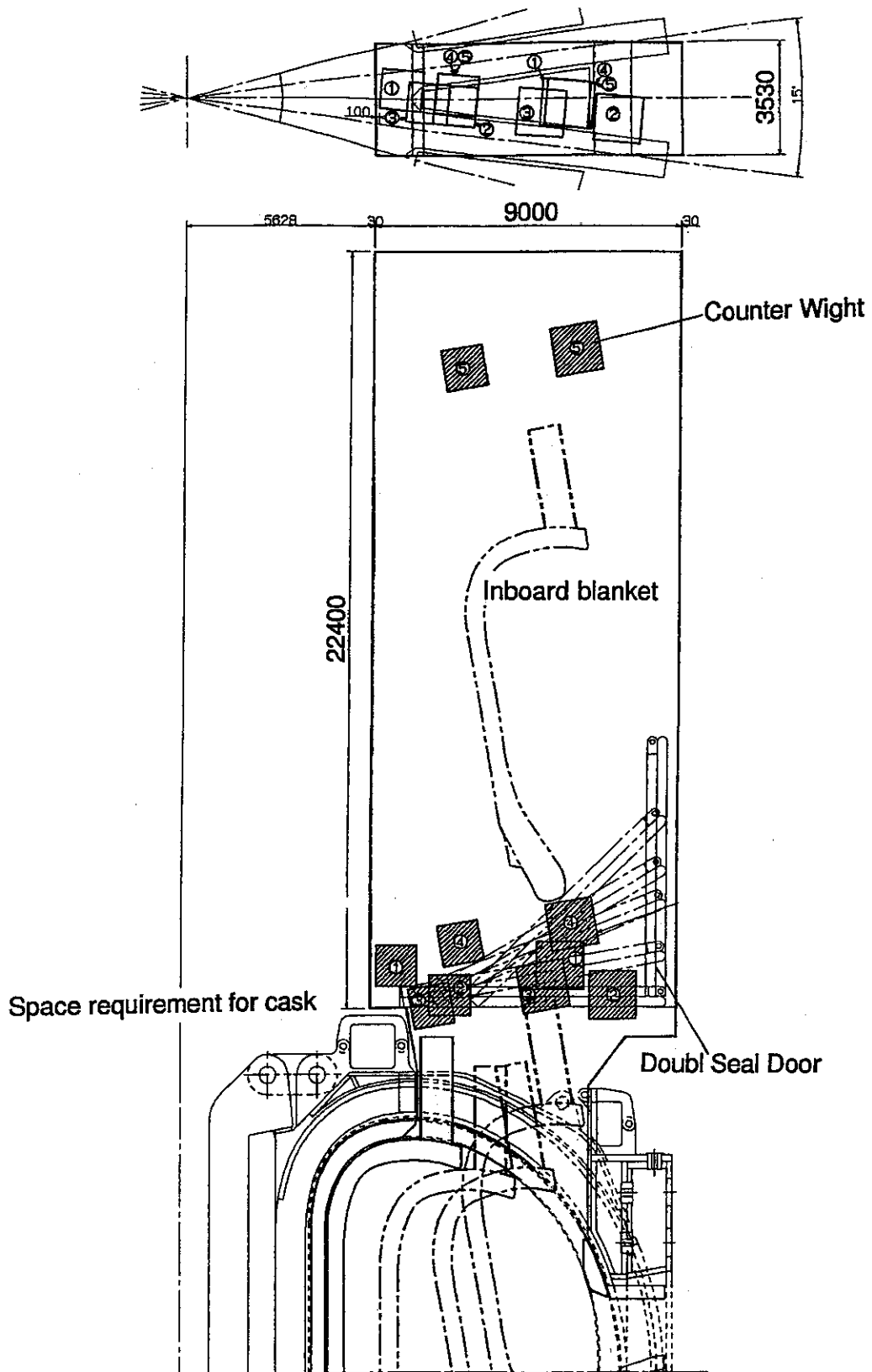

Fig. 3.5.1 Space requirement and interior layout of maintenance cask-1

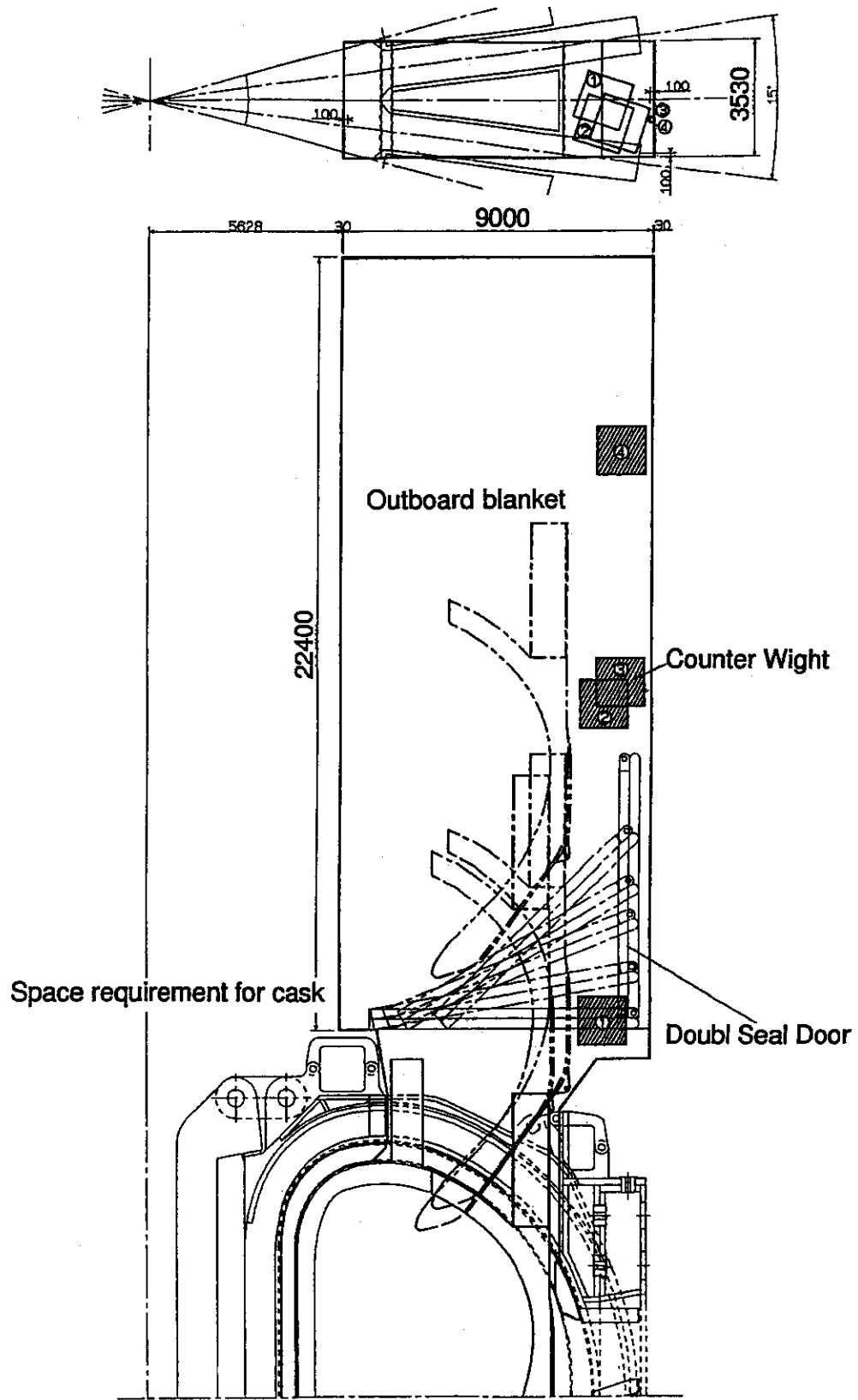

Fig. 3.5.2 Space requirement and interior layout of maintenance cask-2

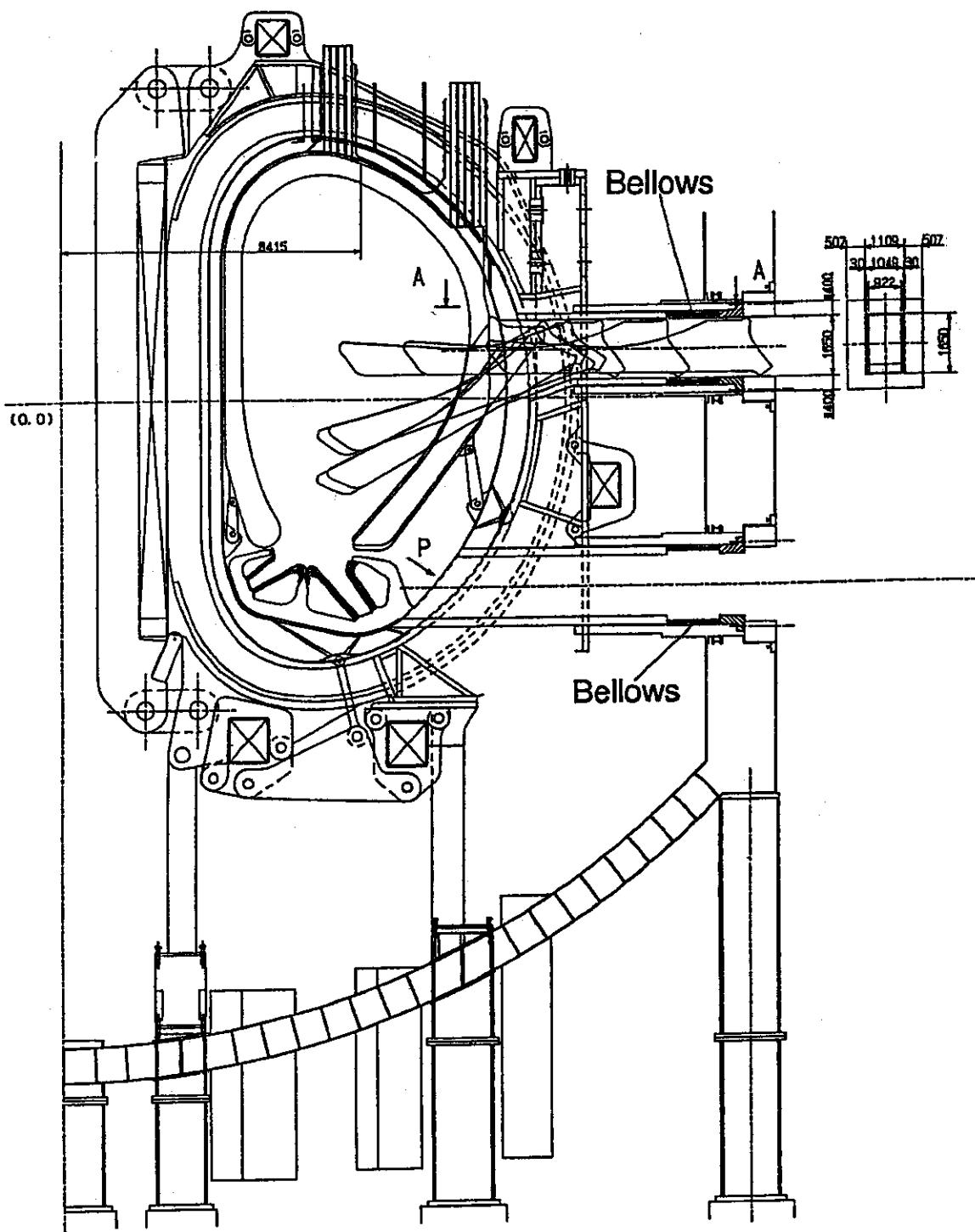

Fig. 3.5.3(a) Removal of blanket test modules from horizontal port-1

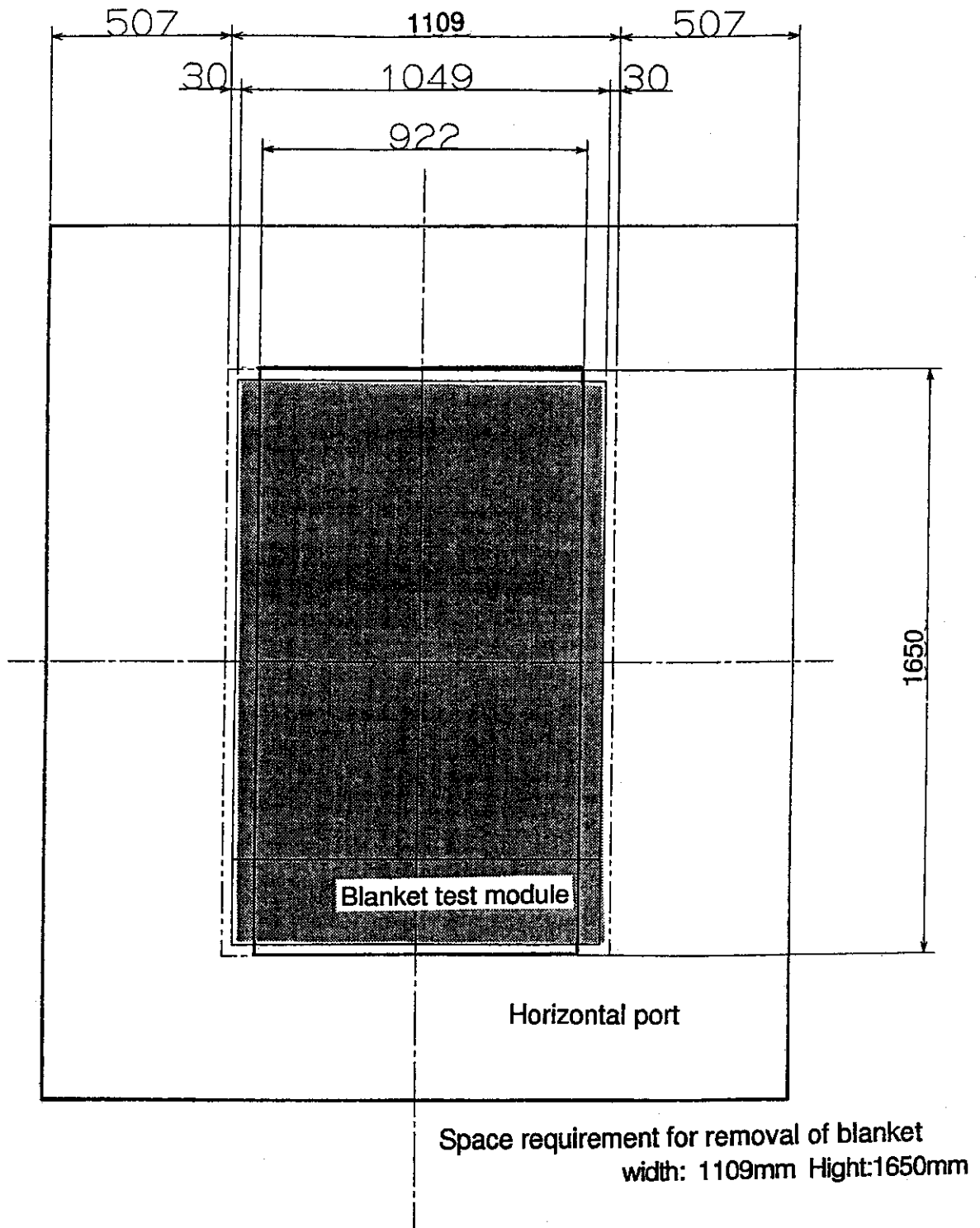
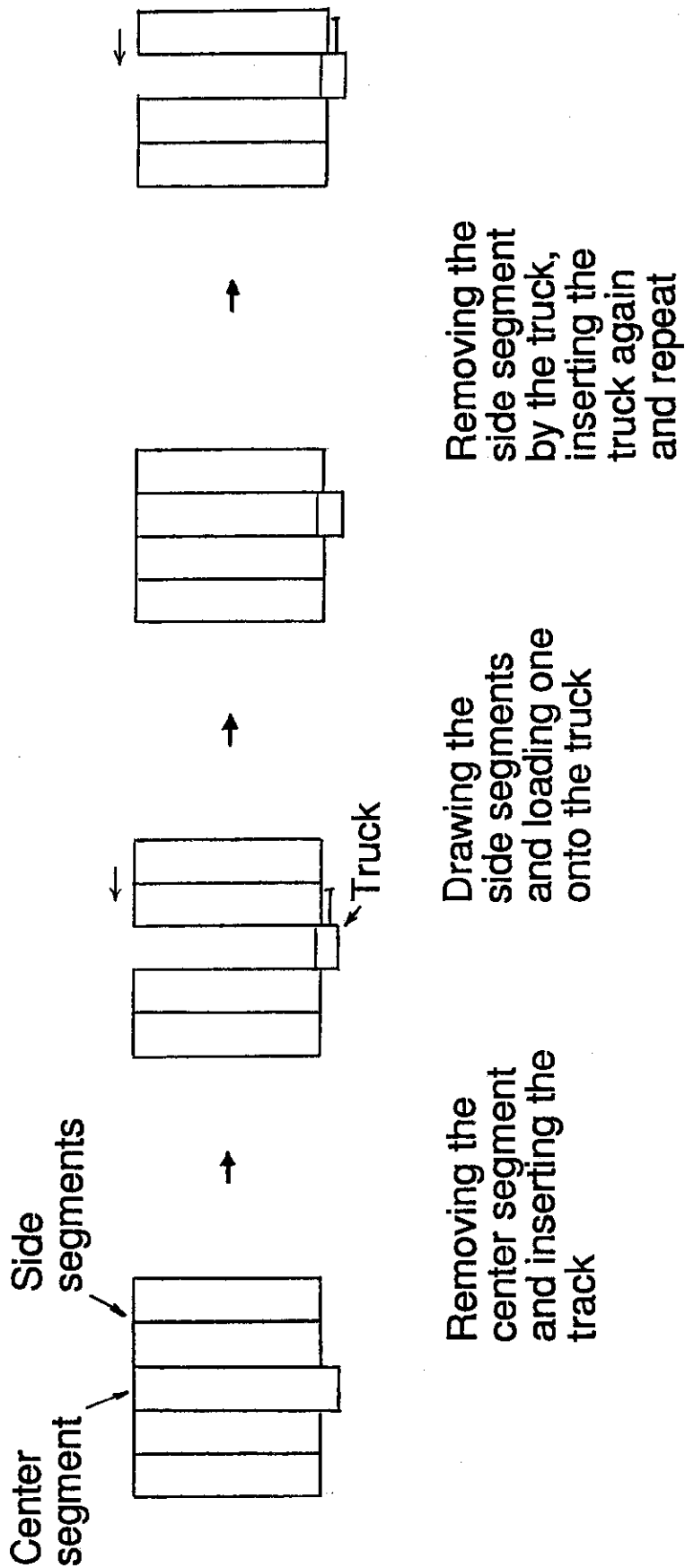

Fig. 3.5.3(b) Removal of blanket test modules from horizontal port-2



View from the pumping duct

Fig. 3.5.4 Procedure of removing divertor segments

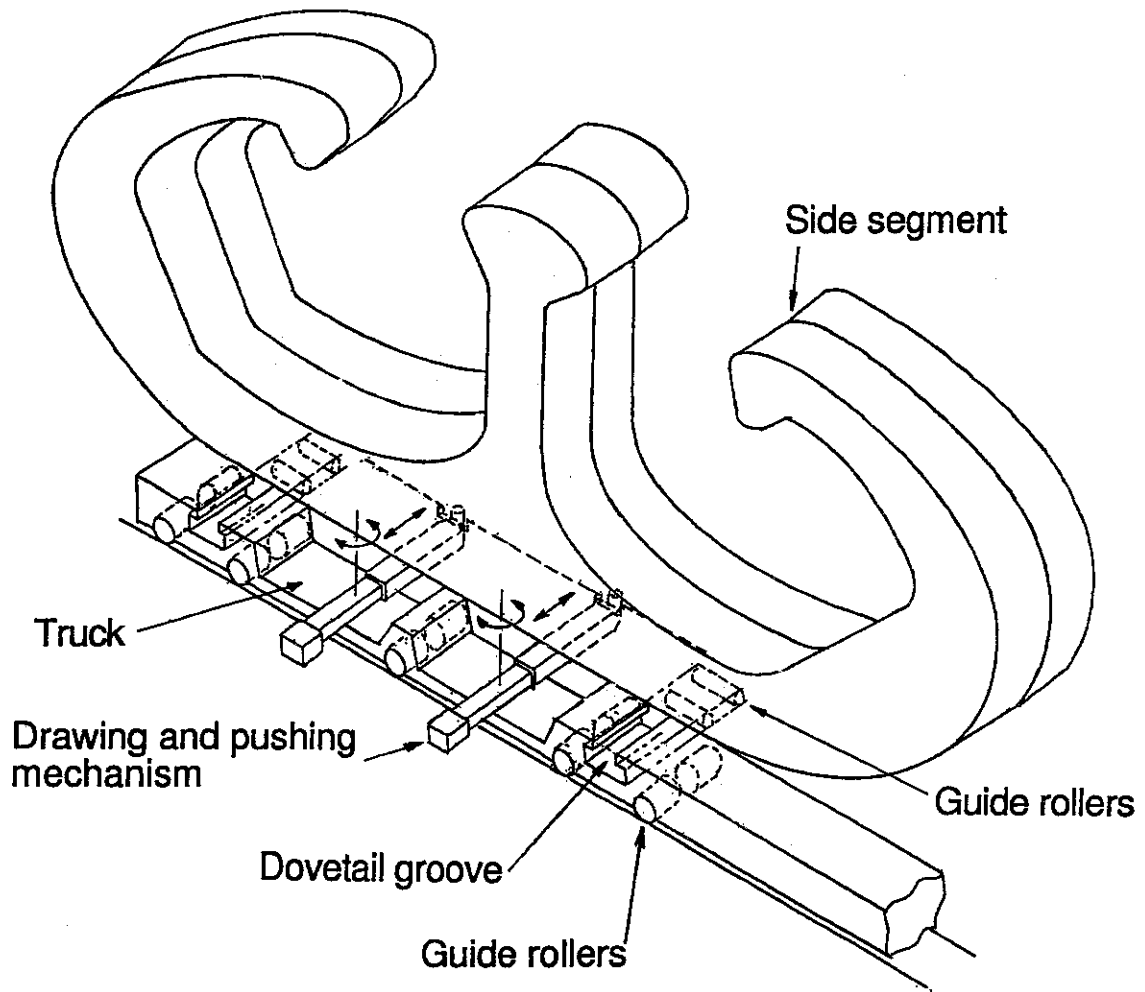

Fig. 3.5.5 Overview of the cassette maintenance system